

VERSION HISTORY

Index:

- P01 VERSION HISTORY
- P02 BLOCK DIAGRAM
- P03 POWER TREE
- P04 GPIO ASSIGNMENT
- P05 POWER
- P07 SOC1
- P08 SOC2
- P09 DDR3
- P10 FLASH
- P12 AUDIO
- P13 USB CARD HDMI
- P14 WIFI

Revision	Description	Date	Drawn	Checked	Approved
Ver 0.1	Releas version	2020-12-31			
Ver 1.0	AddAW859 Add UART2 /5 and SPI test point	2020-04-07	YJY	JIAYONG	YINWEI

BLOCK

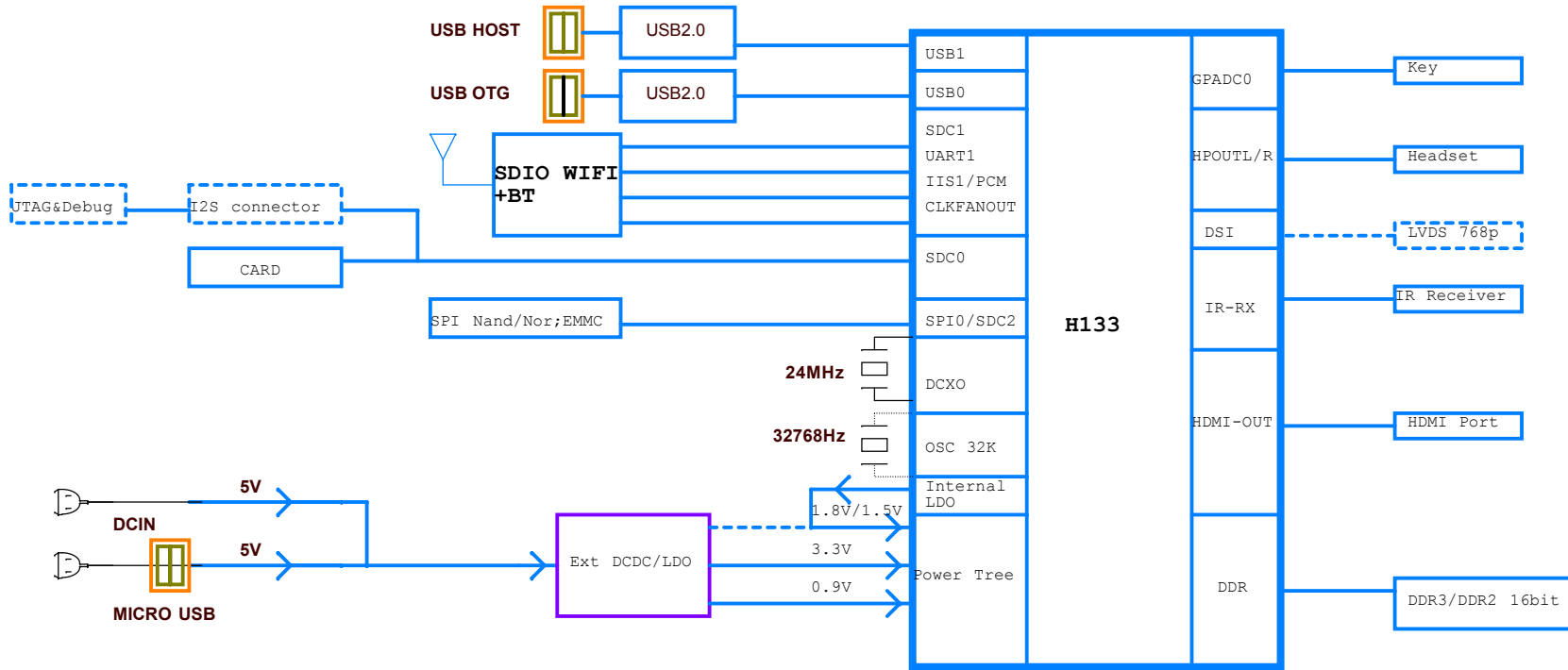

DEFAULT POWER ON
 DEFAULT POWER OFF

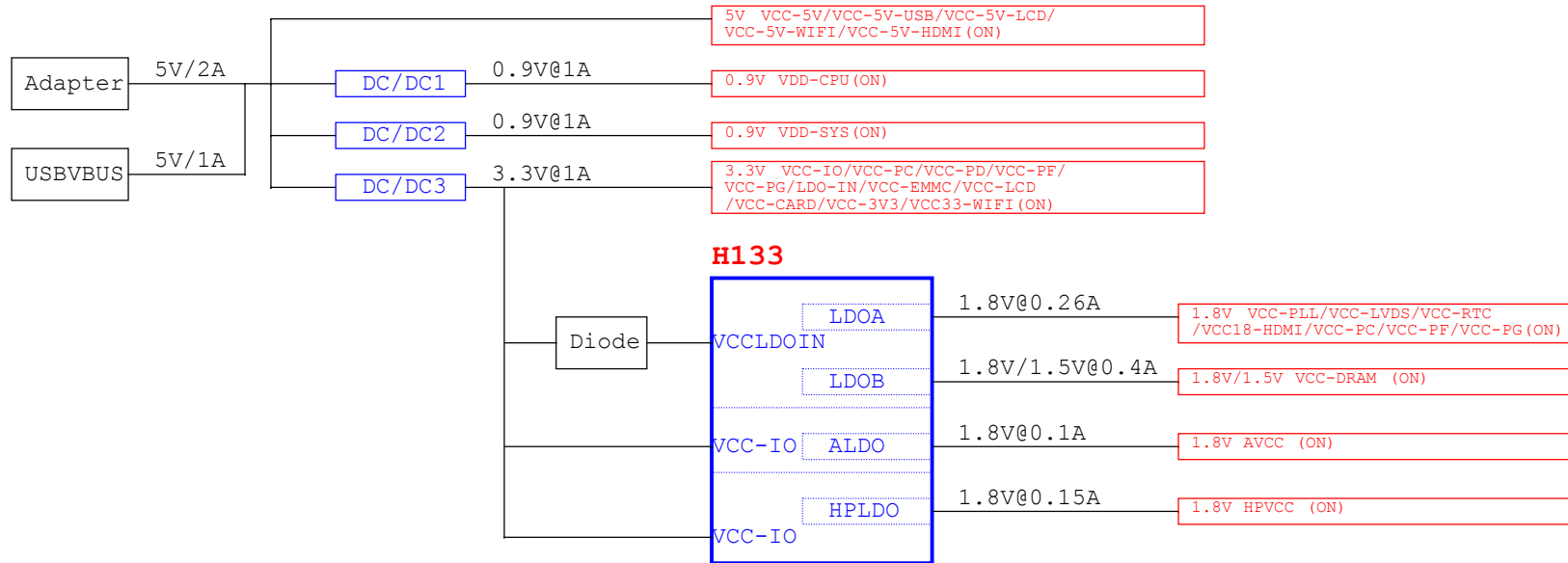

GPIO ASSIGNMENT

Ball Number	Ball Name	GPIO Multiplex Function
D15	PB0	PWM3/IR_TX/TWI2_SCK/SPI1_WP/DBI_TE/UART0_TX/UART2_TX/SPDIF_OUT/PB_EINT0
D14	PB1	PWM4/I2S2_DOUT3/TWI2_SDA/I2S2_DIN3/UART0_RX/UART2_RX/IR_RX/PB_EINT1
D13	PB8	DMIC_DATA3/PWM5/TWI2_SCK/SPI1_HOLD/DBI_DCX/DBI_WRX/UART0_TX/UART1_TX/PB_EINT8
C14	PB9	DMIC_DATA2/PWM6/TWI2_SDA/SPI1_MISO/DBI_SDI/DBI_TE/DBI_DCX/UART0_RX/UART1_RX/PB_EINT9
C13	PB10	DMIC_DATA1/PWM7/TWI0_SCK/SPI1_MOSI/DBI_SDO/CLK_FANOUT0/UART1_RTS/PB_EINT10
B15	PB11	DMIC_DATA0/PWM2/TWI0_SDA/SPI1_CLK/DBI_SCLK/CLK_FANOUT1/UART1_CTS/PB_EINT11
B14	PB12	DMIC_CLK/PWM0/SPDIF_IN/SPI1_CS/DBI_CSX/CLK_FANOUT2/IR_RX/PB_EINT12

Ball Number	Ball Name	GPIO Multiplex Function
F3	PC2	SPI0_CLK/SDC2_CLK/PC_EINT2
F2	PC3	SPI0_CS0/SDC2_CMD/PC_EINT3
F1	PC4	SPI0_MOSI/SDC2_D2/BOOT_SEL0/PC_EINT4
G3	PC5	SPI0_MISO/SDC2_D1/BOOT_SEL1/PC_EINT5
G2	PC6	SPI0_WP/SDC2_D0/UART3_TX/TWI3_SCK/DBG_CLK/PC_EINT6
H3	PC7	SPI0_HOLD/SDC2_D3/UART3_RX/TWI3_SDA/TCON_TRIG/PC_EINT7

Ball Number	Ball Name	GPIO Multiplex Function
N15	PD0	LCD0_D2/LVDS0_V0P/DSI_D0P/TWI0_SCK/PD_EINT0
N14	PD1	LCD0_D3/LVDS0_V0N/DSI_D0N/UART2_TX/PD_EINT1
M15	PD2	LCD0_D4/LVDS0_V1P/DSI_D1P/UART2_RX/PD_EINT2
M14	PD3	LCD0_D5/LVDS0_V1N/DSI_D1N/UART2_RTS/PD_EINT3
L15	PD4	LCD0_D6/LVDS0_V2P/DSI_CKP/UART2_CTS/PD_EINT4
L14	PD5	LCD0_D7/LVDS0_V2N/DSI_CKN/UART5_TX/PD_EINT5
K15	PD6	LCD0_D10/LVDS0_CKP/DSI_D2P/UART5_RX/PD_EINT6
K14	PD7	LCD0_D11/LVDS0_CKN/DSI_D2N/UART4_TX/PD_EINT7
J15	PD8	LCD0_D12/LVDS0_V3P/DSI_D3P/UART4_RX/PD_EINT8
J14	PD9	LCD0_D13/LVDS0_V3N/DSI_D3N/PWM6/PD_EINT9

Ball Number	Ball Name	GPIO Multiplex Function
B8	PG0	SDC1_CLK/UART3_TX/RGMII_RXCTRL/RMII_CRS_DV/PWM7/PG_EINT0
C9	PG1	SDC1_CMD/UART3_RX/RGMII_RXD0/RMII_RXD0/PWM6/PG_EINT1
A8	PG2	SDC1_D0/UART3_RTS/RGMII_RXD1/RMII_RXD1/UART4_TX/PG_EINT2
B7	PG3	SDC1_D1/UART3_CTS/RGMII_TXCK/RMII_TXCK/UART4_RX/PG_EINT3
A6	PG4	SDC1_D2/UART5_TX/RGMII_TXD0/RMII_TXD0/PWM5/PG_EINT4
C7	PG5	SDC1_D3/UART5_RX/RGMII_TXD1/RMII_TXD1/PWM4/PG_EINT5
B4	PG6	UART1_TX/TWI2_SCK/RGMII_TXD2/PWM1/PG_EINT6
A3	PG7	UART1_RX/TWI2_SDA/RGMII_TXD3/SPDIF_IN/PG_EINT7
B3	PG8	UART1_RTS/TWI1_SCK/RGMII_RXD2/UART3_TX/PG_EINT8
A2	PG9	UART1_CTS/TWI1_SDA/RGMII_RXD3/UART3_RX/PG_EINT9
C4	PG10	PWM3/TWI3_SCK/RGMII_RXCK/CLK_FANOUT0/IR_RX/PG_EINT10
B6	PG11	I2S1_MCLK/TWI3_SDA/EPHY_25M/CLK_FANOUT1/TCON_TRIG/PG_EINT11
C6	PG12	I2S1_LRCK/TWI0_SCK/RGMII_TXCTRL/RMII_TXEN/CLK_FANOUT2/PWM0/UART1_TX/PG_EINT12
B5	PG13	I2S1_BCLK/TWI0_SDA/RGMII_CLKIN/RMII_RXER/PWM2/LEDC_DO/UART1_RX/PG_EINT13
C5	PG14	I2S1_DIN0/TWI2_SCK/MDC/I2S1_DOUT1/SPI0_WP/UART1_RTS/PG_EINT14
A4	PG15	I2S1_DOUT0/TWI2_SDA/MDIO/I2S1_DIN1/SPI0_HOLD/UART1_CTS/PG_EINT15
B2	PG16	IR_RX/TCON_TRIG/PWM5/CLK_FANOUT2/SPDIF_IN/LEDC_DO/PG_EINT16
C10	PG17	UART2_TX/TWI3_SCK/PWM7/CLK_FANOUT0/IR_TX/UART0_TX/PG_EINT17
B9	PG18	UART2_RX/TWI3_SDA/PWM6/CLK_FANOUT1/SPDIF_OUT/UART0_RX/PG_EINT18

Ball Number	Ball Name	GPIO Multiplex Function
B1	PF0	SDC0_D1/JTAG_MS/R_JTAG_MS/I2S2_DOUT1/I2S2_DIN0/PF_EINT0
C3	PF1	SDC0_D0/JTAG_DI/R_JTAG_DI/I2S2_DOUT0/I2S2_DIN1/PF_EINT1
C2	PF2	SDC0_CLK/UART0_TX/TWI0_SCK/LEDC_DO/SPDIF_IN/PF_EINT2
D3	PF3	SDC0_CMD/JTAG_DO/R_JTAG_DO/I2S2_BCLK/PF_EINT3
D2	PF4	SDC0_D3/UART0_RX/TWI0_SDA/PWM6/IR_TX/PF_EINT4
D1	PF5	SDC0_D2/JTAG_CK/R_JTAG_CK/I2S2_LRCK/PF_EINT5
E2	PF6	SPDIF_OUT/IR_RX/I2S2_MCLK/PWM5/PF_EINT6

POWER

5V DCIN TO PS

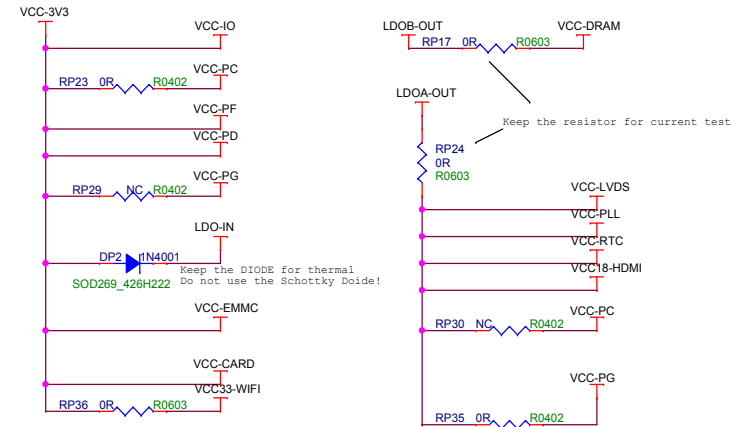
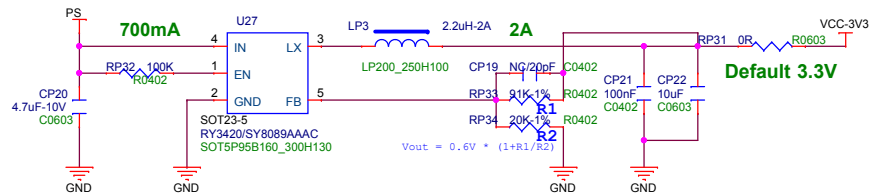
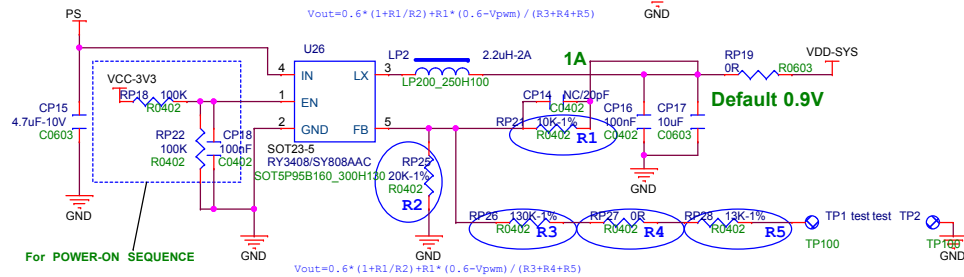
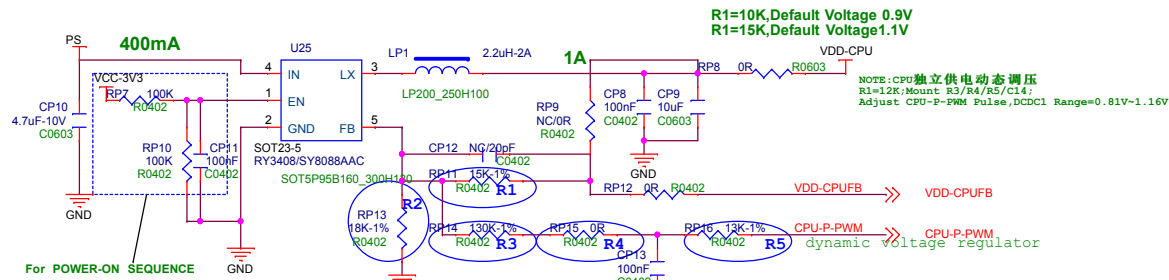
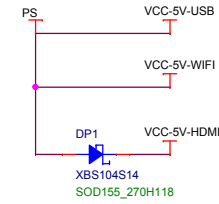
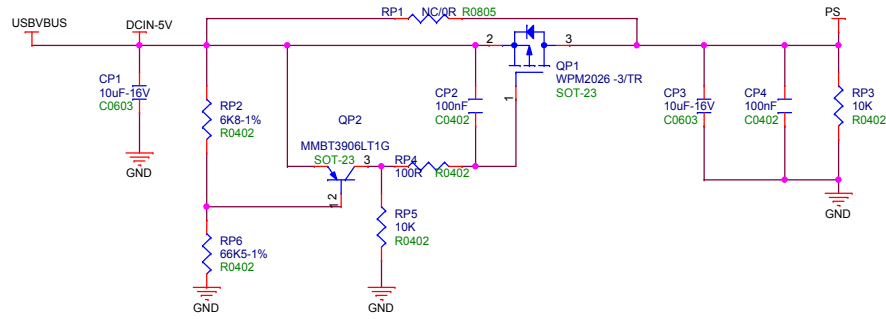

SOC1

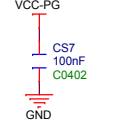
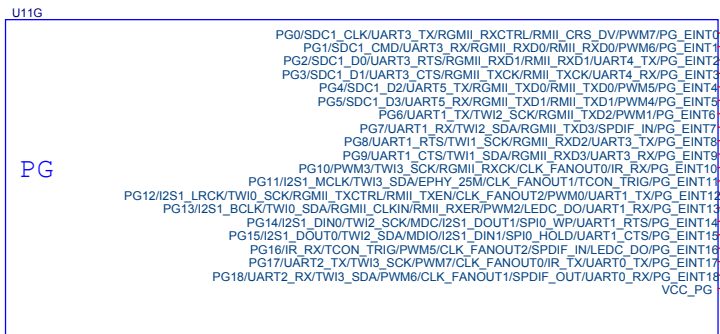
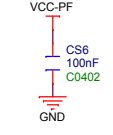
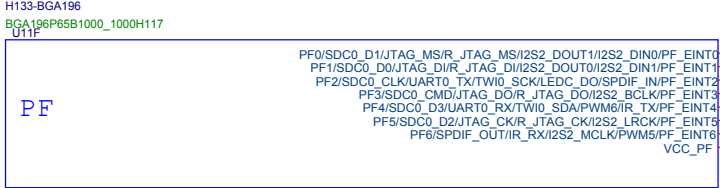
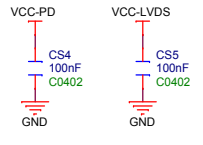
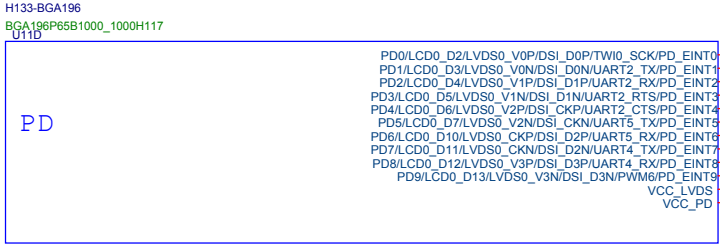
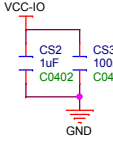
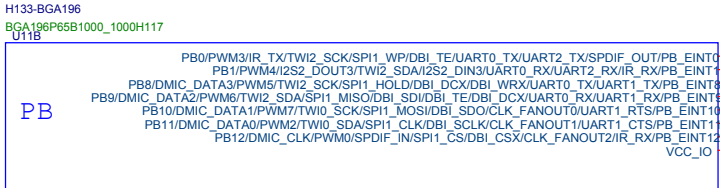
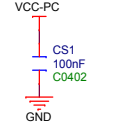
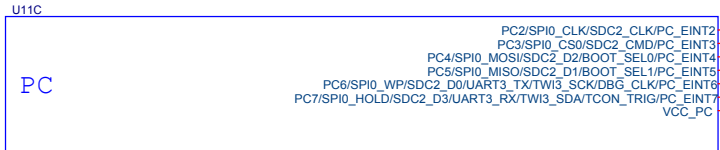

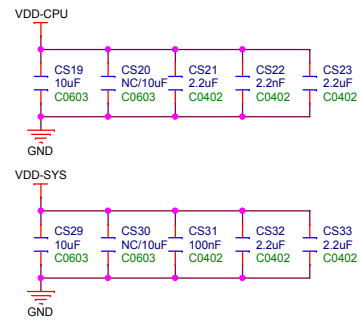
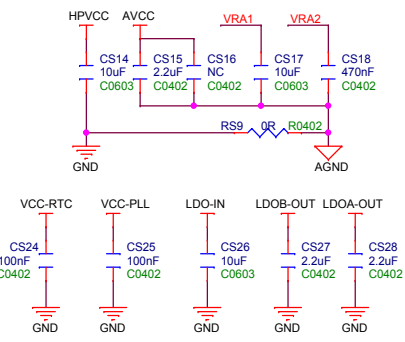
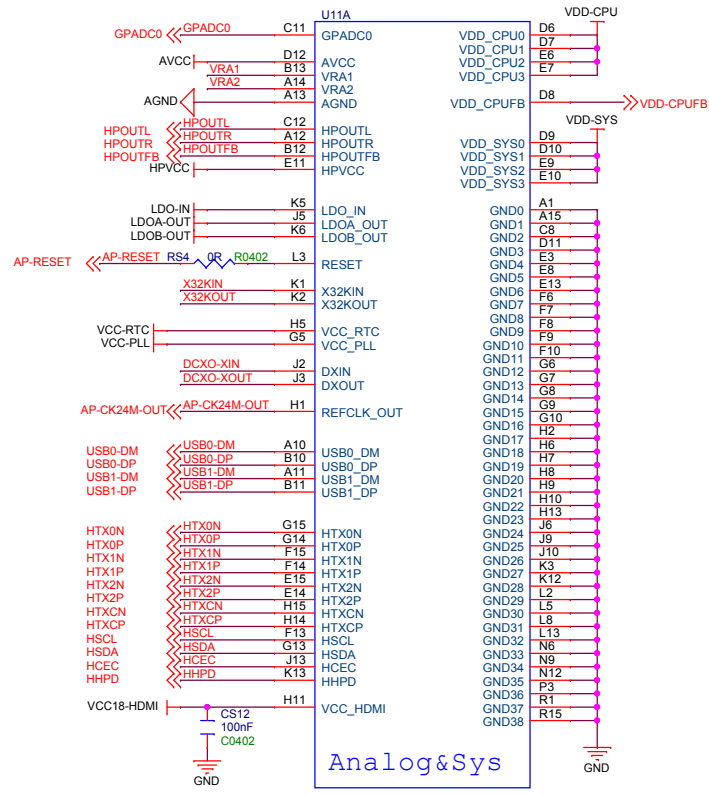
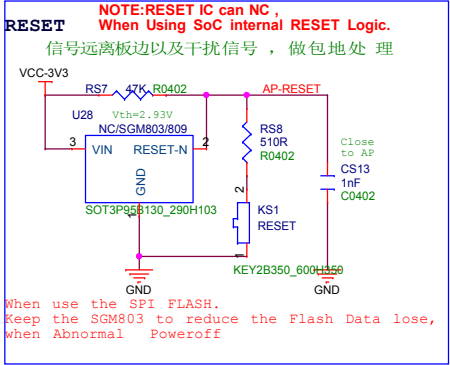
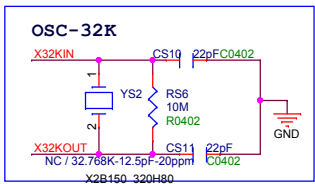
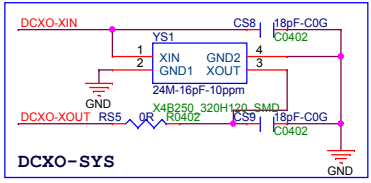

DDR3

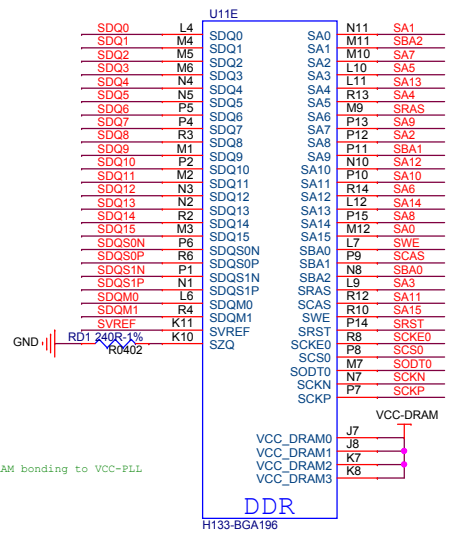

NOTE:
1.VDD18-DRAM bonding to VCC-PLL

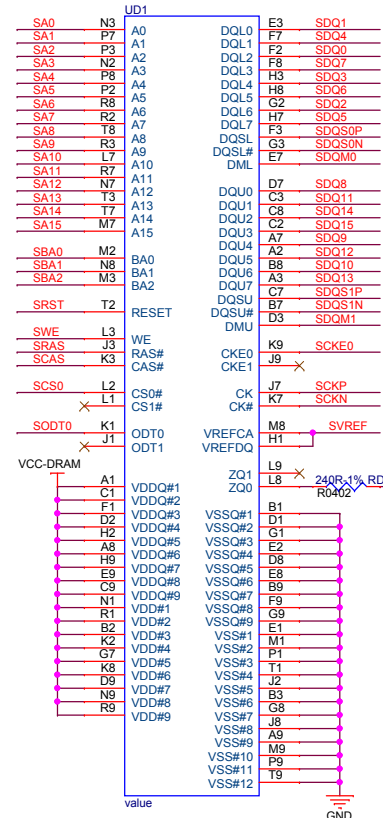
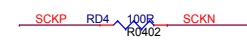
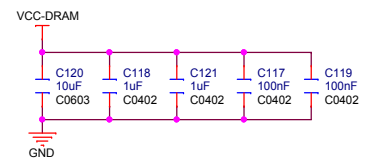
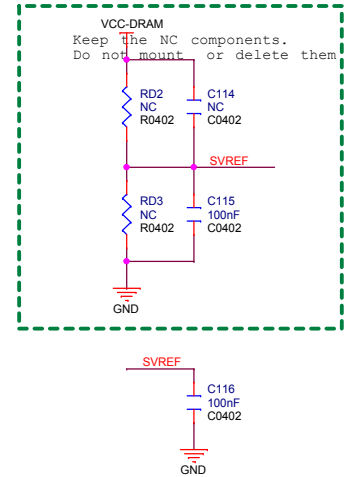
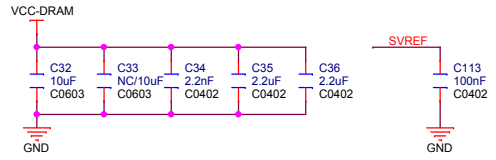

SPI

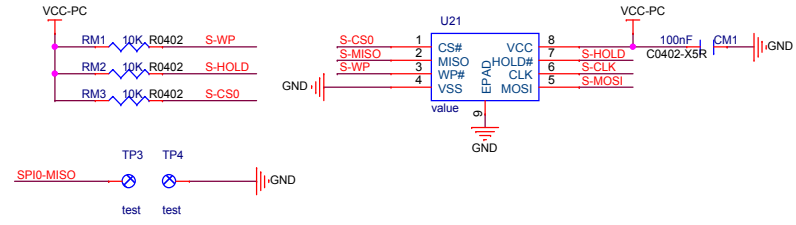

Download TP.
Must place between SOC and Flash.

EMMC

SPI FLASH and EMMC only can choose one of them.
Both Layout in PCB will effect the SI

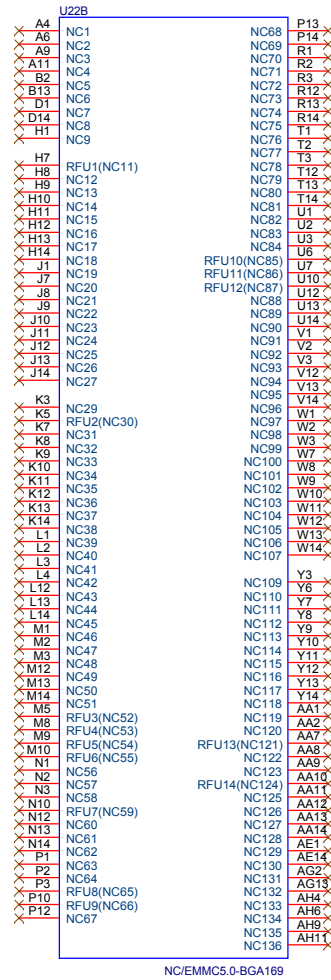

Download TP.
Must place between SOC and Flash.

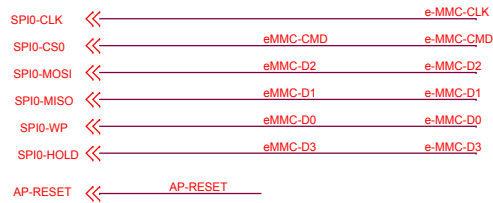
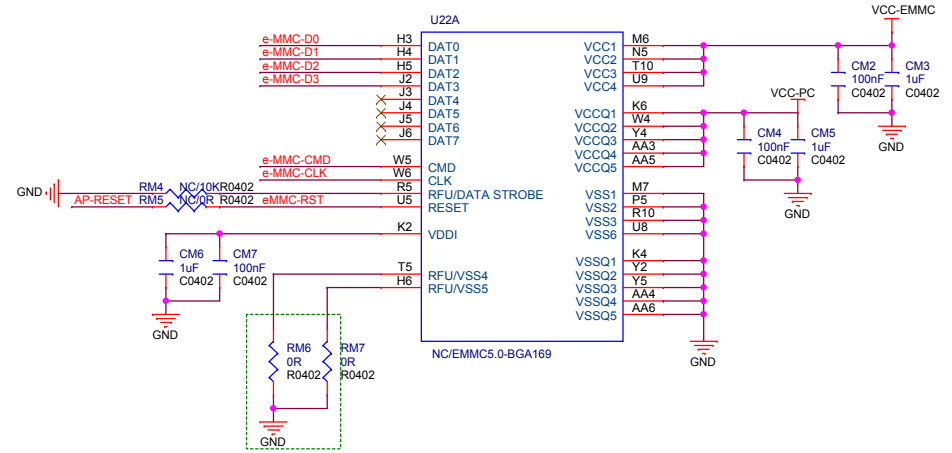
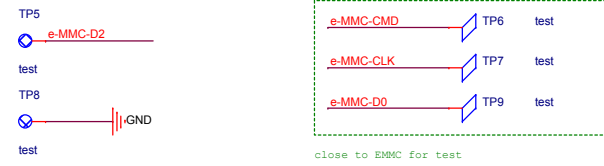

Audio

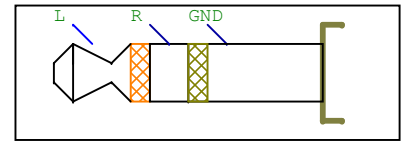
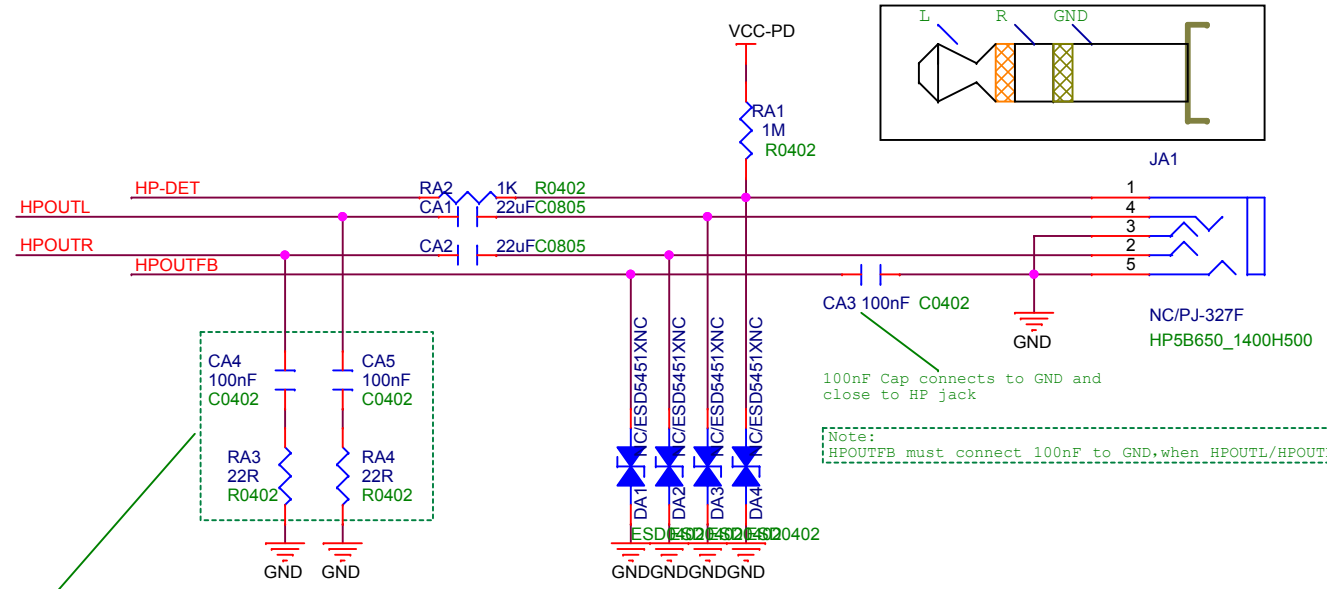



Note:
HPOUTL/HPOUTR must be connected to this circuit network,
when HPOUTL/HPOUTR is used.

Note:
HPOUTFB must connect 100nF to GND, when HPOUTL/HPOUTR is used.

100nF Cap connects to GND and
close to HP jack

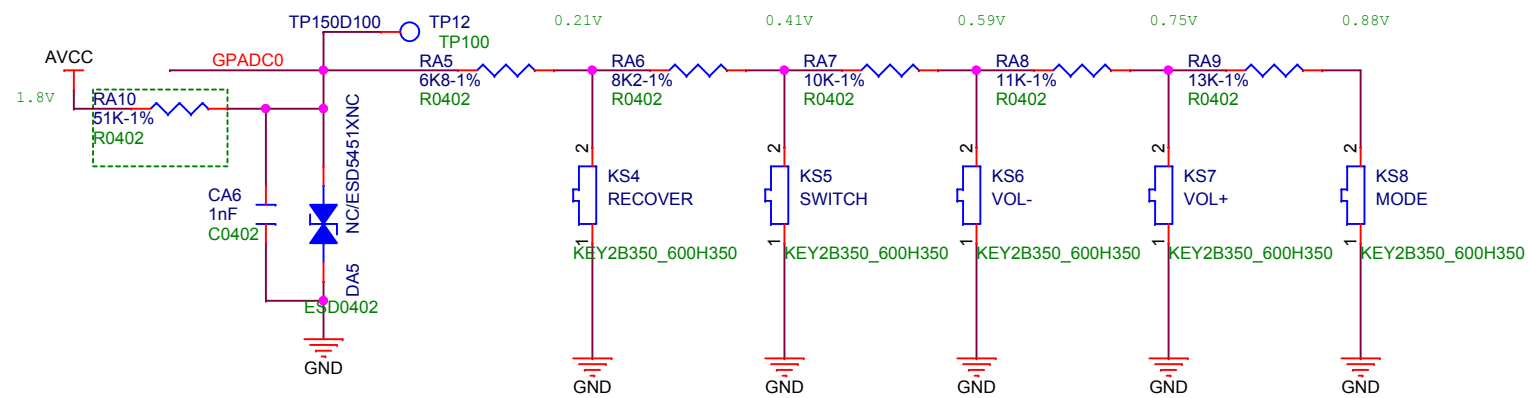
KEY ADC



			AllWinner Technology Co., Ltd		
			Design Name		
Size	Page Name		Rev		
A4	12 AUDIO & KEY				
Date:	Friday, April 09, 2021		Sheet	10	of 12

USB

- USB-ID
- USB0-VBUSDET
- USB-DRVVBUS
- USB0-DM
- USB0-DP
- USB1-DM
- USB1-DP

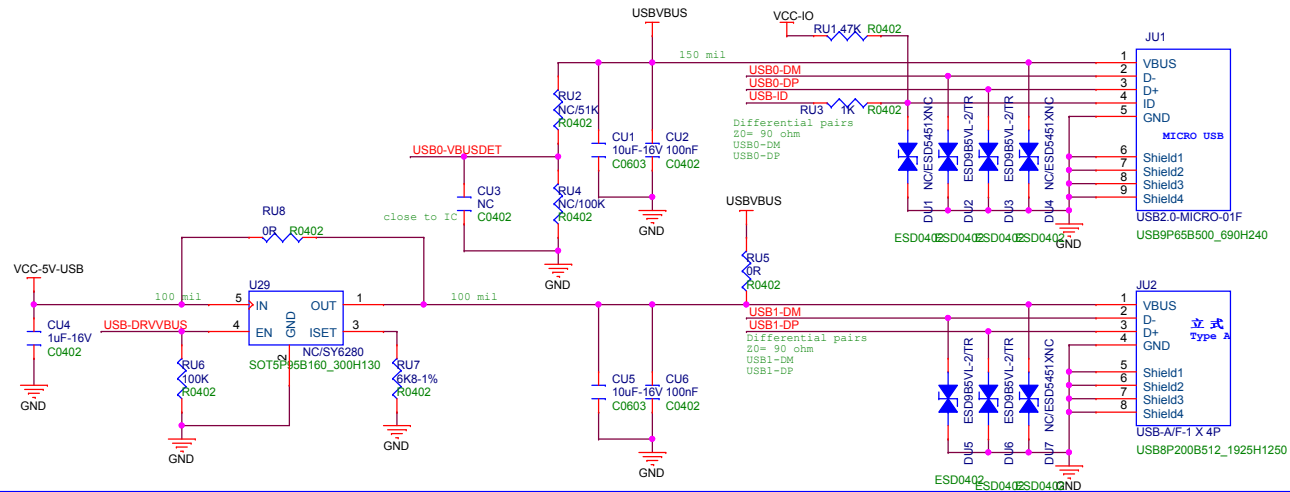

SDC0/JTAG Debug

- SDC0-D1
- SDC0-D0
- SDC0-CLK
- SDC0-CMD
- SDC0-D3
- SDC0-D2
- SDC0-DET

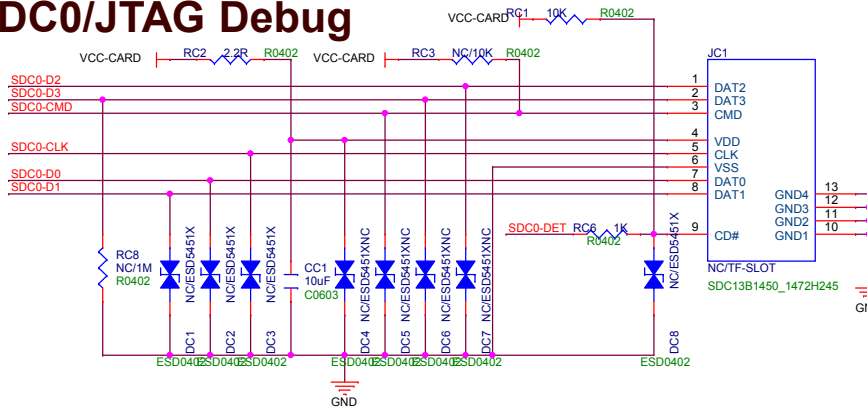

UART DEBUG

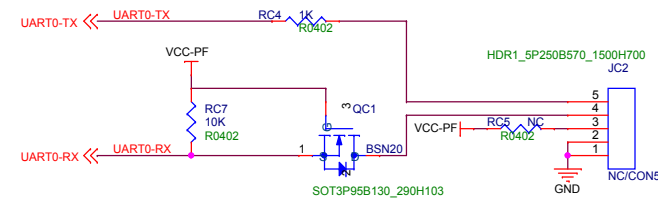

HDMI

- HCEC
- HHPD
- HSCL
- HSDA
- HTX0N
- HTX0P
- HTX1N
- HTX1P
- HTX2N
- HTX2P
- HTXCN
- HTXCP

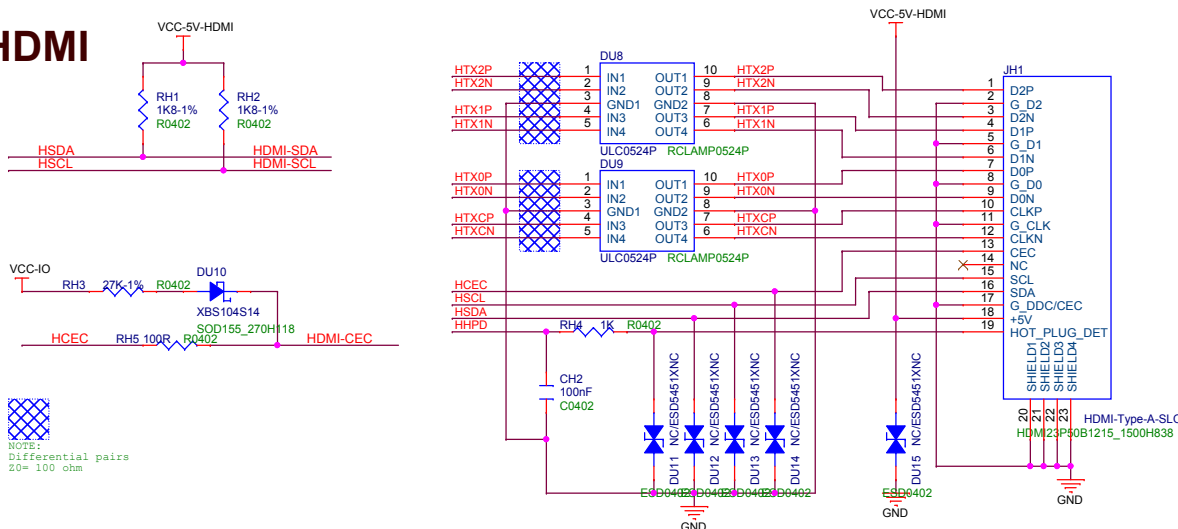

IR-RX

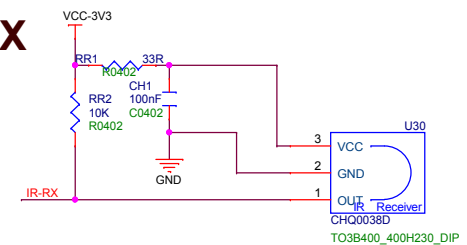

NOTE:
Differential pairs
20= 100 ohm

XR819S ON BOARD

- SDC1-CLK <> WL-SDIO-CLK-AP
- SDC1-CMD <> WL-SDIO-CMD
- SDC1-D0 <> WL-SDIO-D0
- SDC1-D1 <> WL-SDIO-D1
- SDC1-D2 <> WL-SDIO-D2
- SDC1-D3 <> WL-SDIO-D3
- WL-REG-ON <> WL-RESETN
- WL-WAKE-AP <> WL-WAKE-AP
- AP-CLKM-OUT <> AP-CLK-OUT
- PG11 <> PG11
- UART1-TX <> BT-HCI-RX
- UART1-RX <> BT-HCI-TX
- UART1-RTS <> BT-HCI-CTS
- UART1-CTS <> BT-HCI-RTS
- BT-WAKE-AP <> BT-WUP-HOST
- AP-WAKE-BT <> BT-HOST-WUP
- BT-RESETN <> BT-RESETN
- WL-REG-ON <> WL-RESETN
- I2S1-BCLK <> BT-PCM-CLK
- I2S1-LRCK <> BT-PCM-SYNC
- I2S1-DOUT0 <> BT-PCM-DIN
- I2S1-DIN0 <> BT-PCM-DOUT



Clock Source	CW5	RW3	RW7
AP-CLK-OUT	0R	NC	0R
External Crystal	20pF	0R	NC

AW859

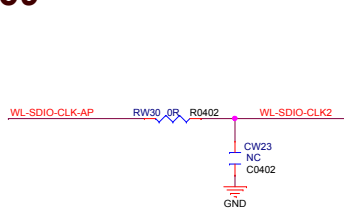

- ONLY 1.8V SDIO**
- WL-REG-ON
 - WL-WAKE-AP
 - WL-SDIO-D2
 - WL-SDIO-D3
 - WL-SDIO-CMD
 - WL-SDIO-CLK2
 - WL-SDIO-D0
 - WL-SDIO-D1

- AW859 use internal 32khz Keep for other Module
- PG11 RW21 NC R0402 X32KFOU1
- BT-PCM-DOUT
- BT-PCM-CLK
- BT-PCM-DIN
- BT-PCM-SYNC
- AP-CK34M-OUT RW24 NC R0402
- AW859 use internal 24mhz Keep for other Module

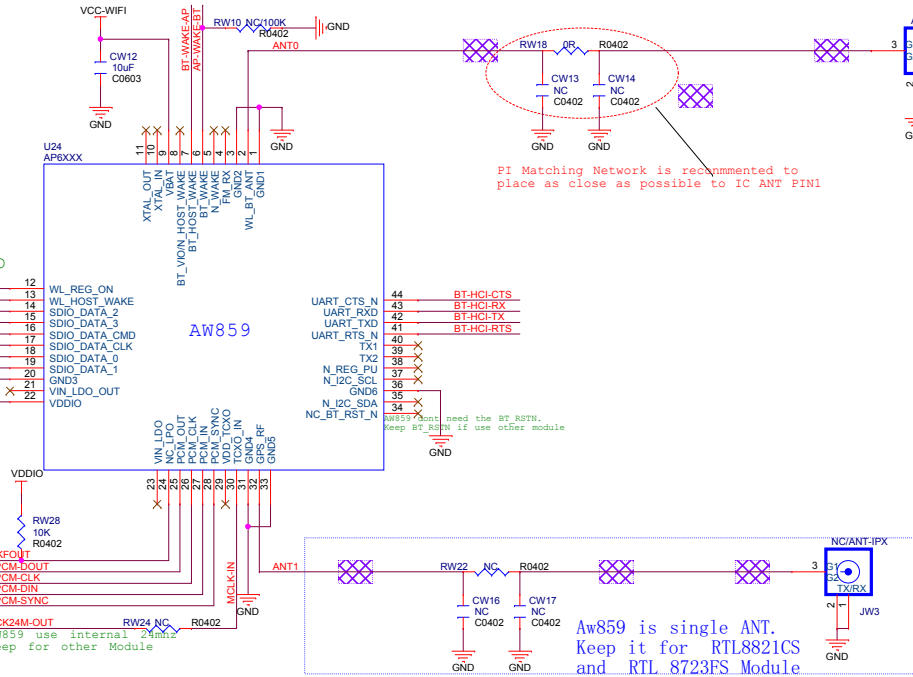

AW859 is single ANT. Keep it for RTL8821CS and RTL_8723FS Module

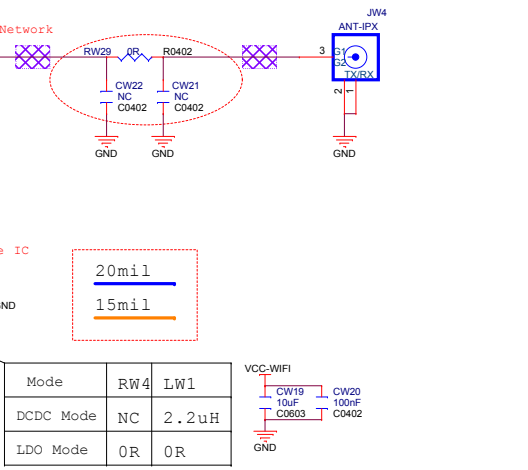

Mode	RW4	LW1
DCDC Mode	NC	2.2uH
LDO Mode	0R	0R

AllWinner Technology Co., Ltd

Design Name: **H133_DONGLE_STD**

Size: Custom

Date: Monday, April 12, 2021

Page Name: **14 WIFI + BT**

Rev: _____

Sheet 12 of 12