

**CTRL**      **TOP\_CLK/DATA**      **IQ\_WIFI**      **WRI\_HB0HB10**

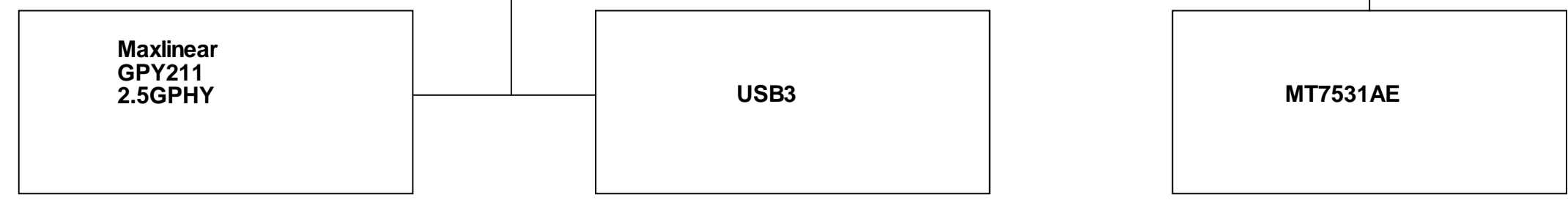

Off-page connection

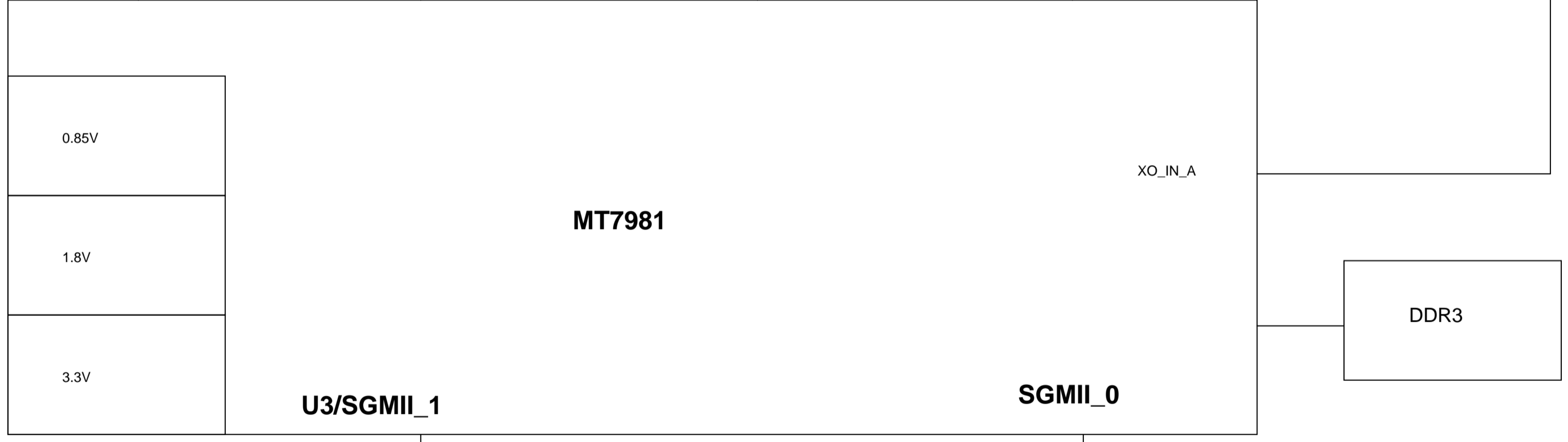
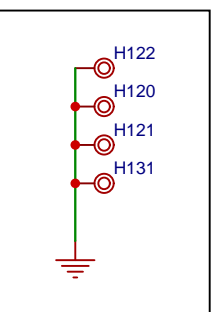
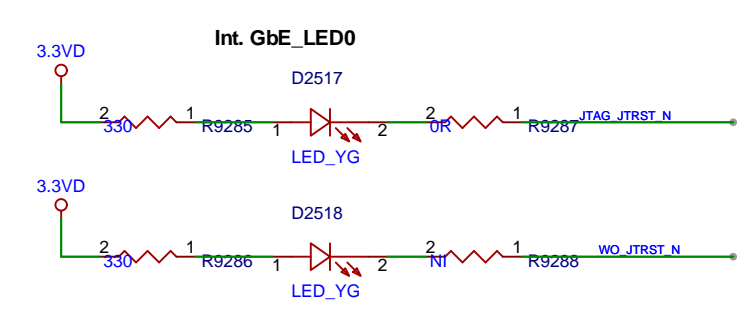
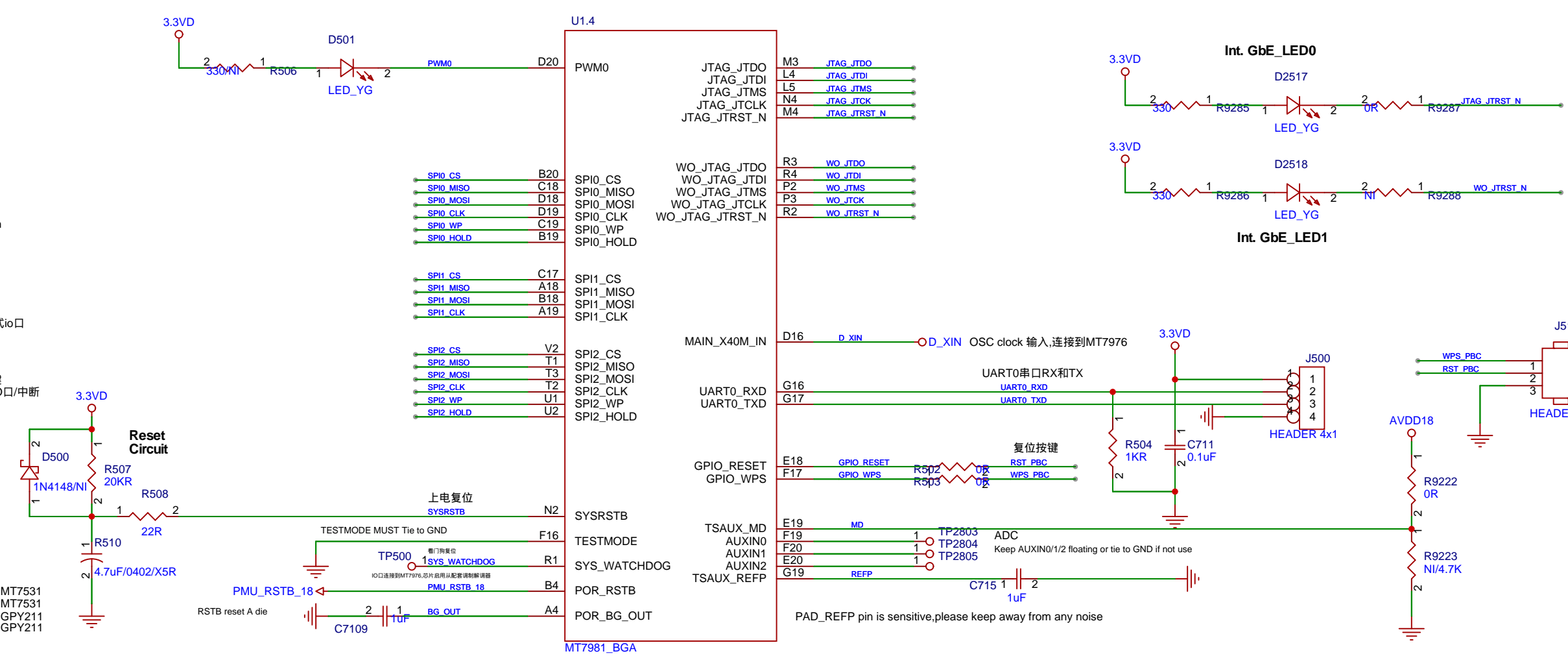
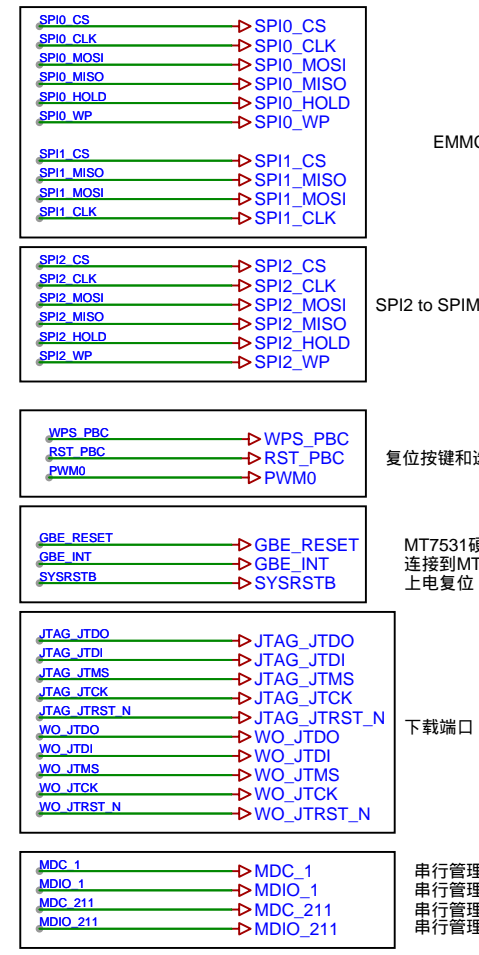

Shielding frame Hole

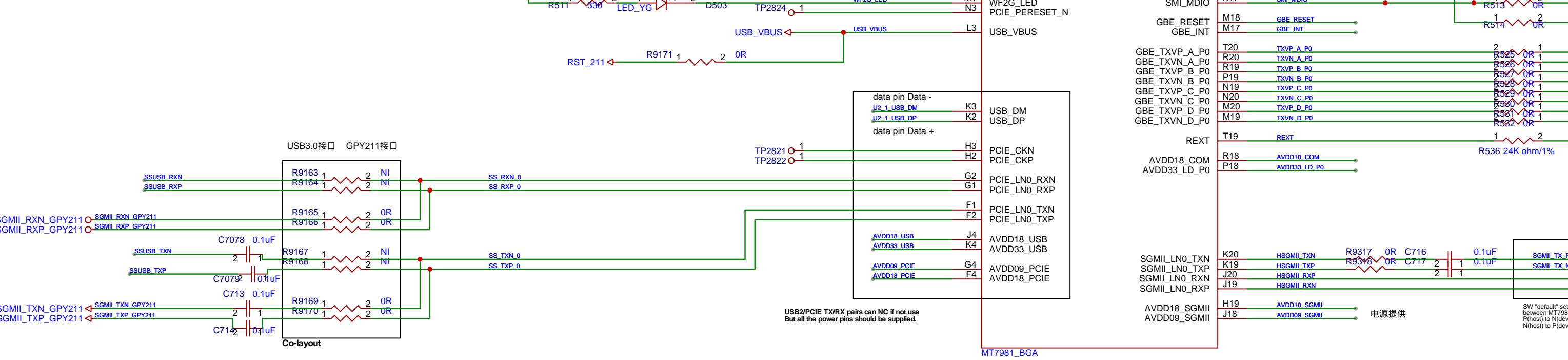

NC/MMDL1/4MIL=> for net name distinguish

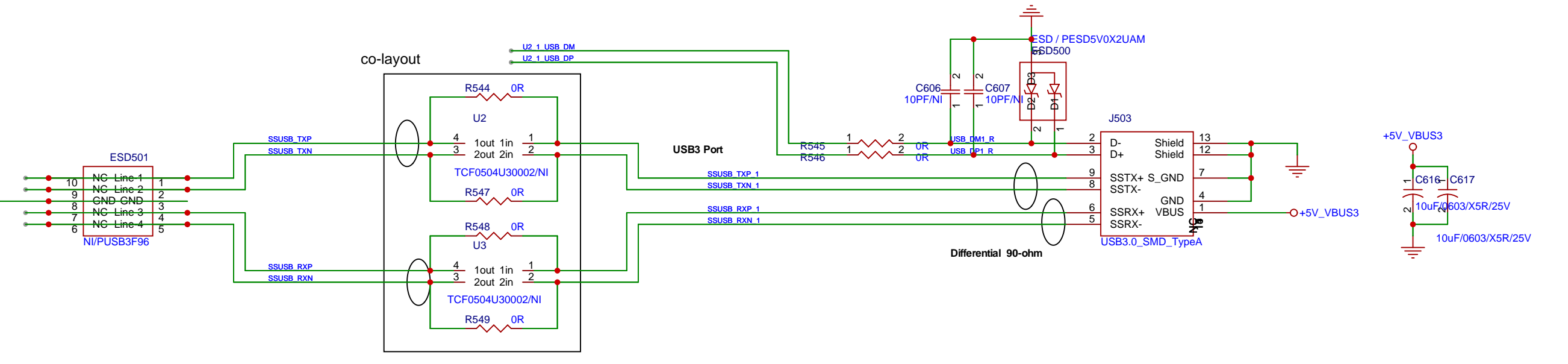
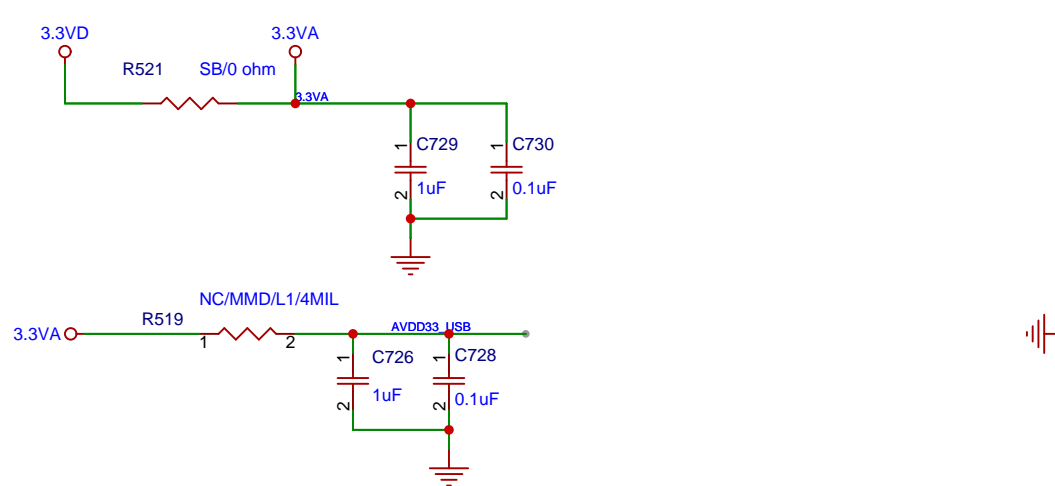
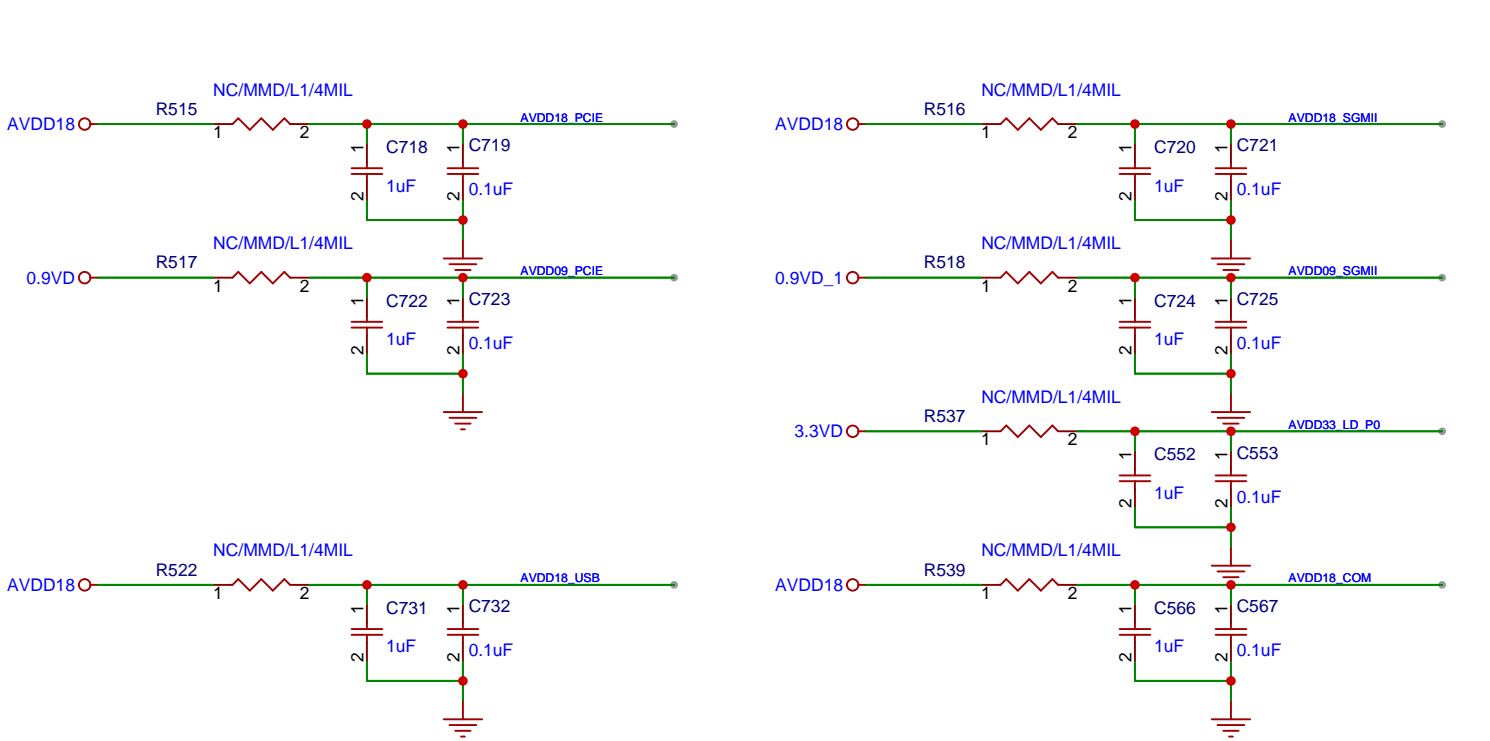

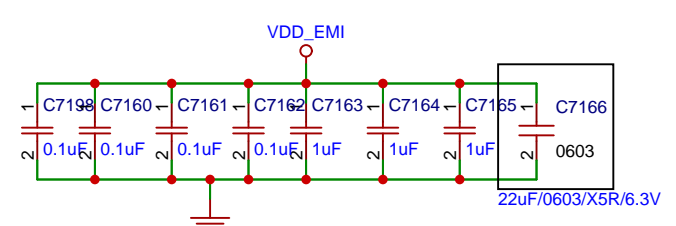
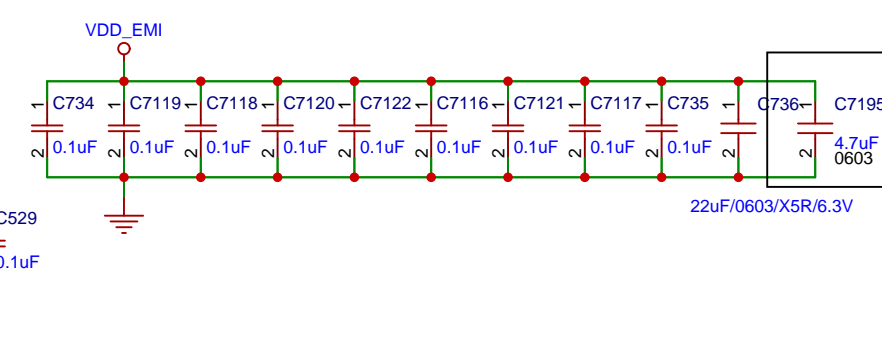
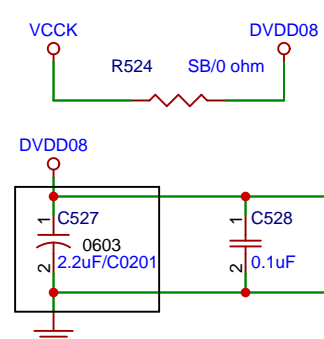
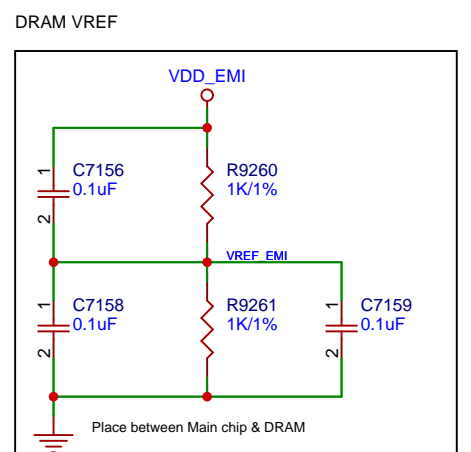
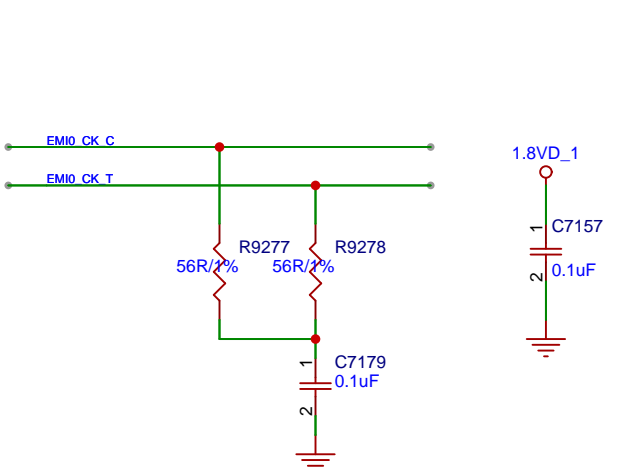
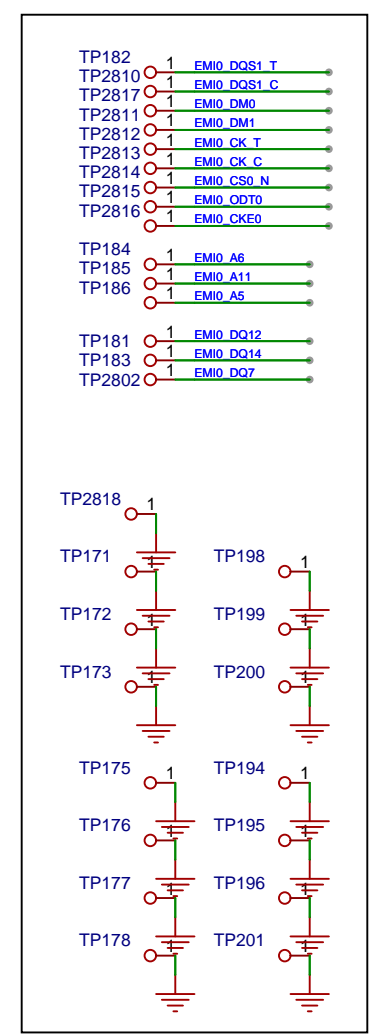
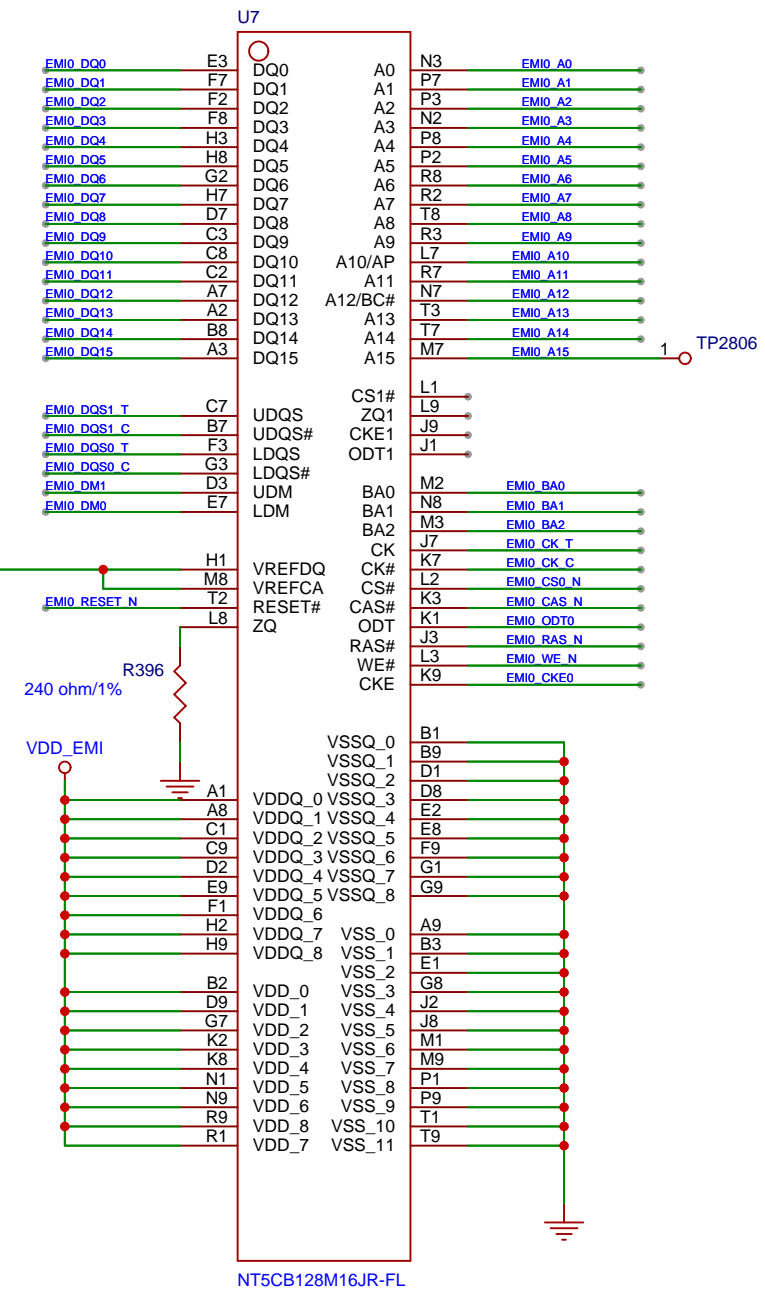
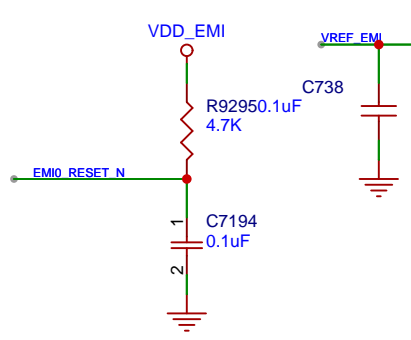
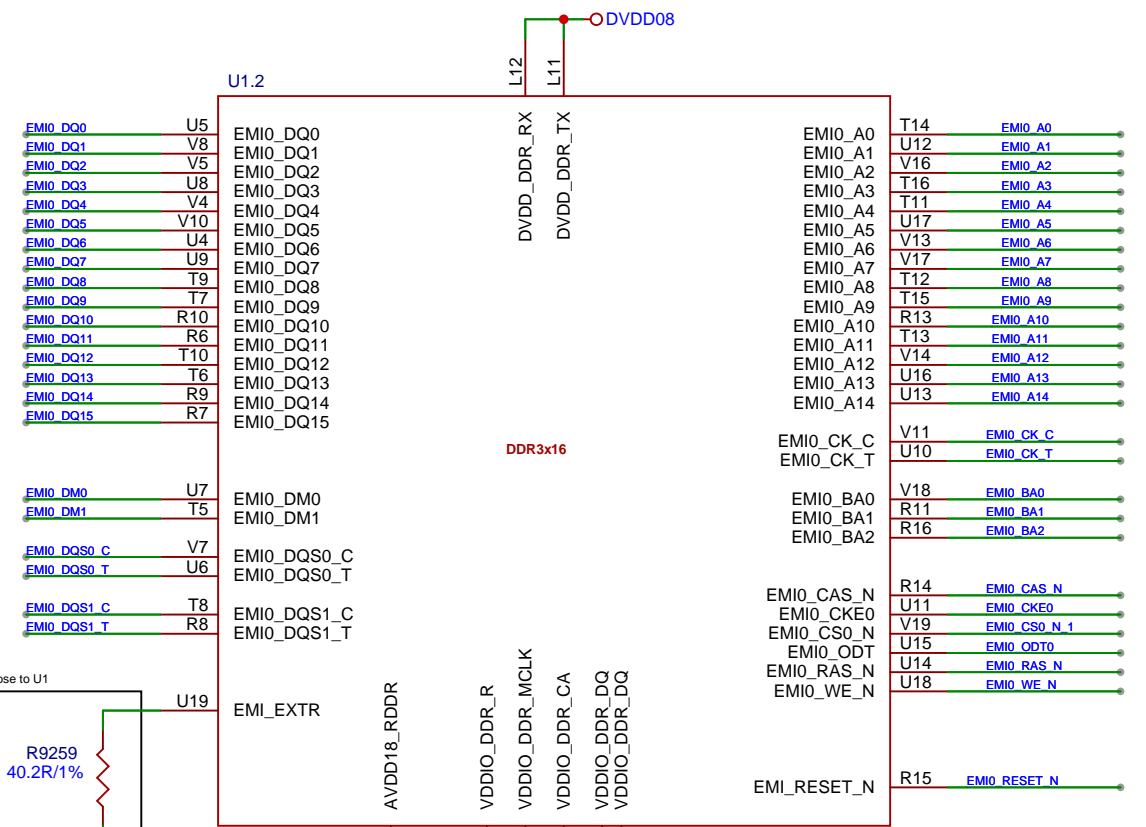

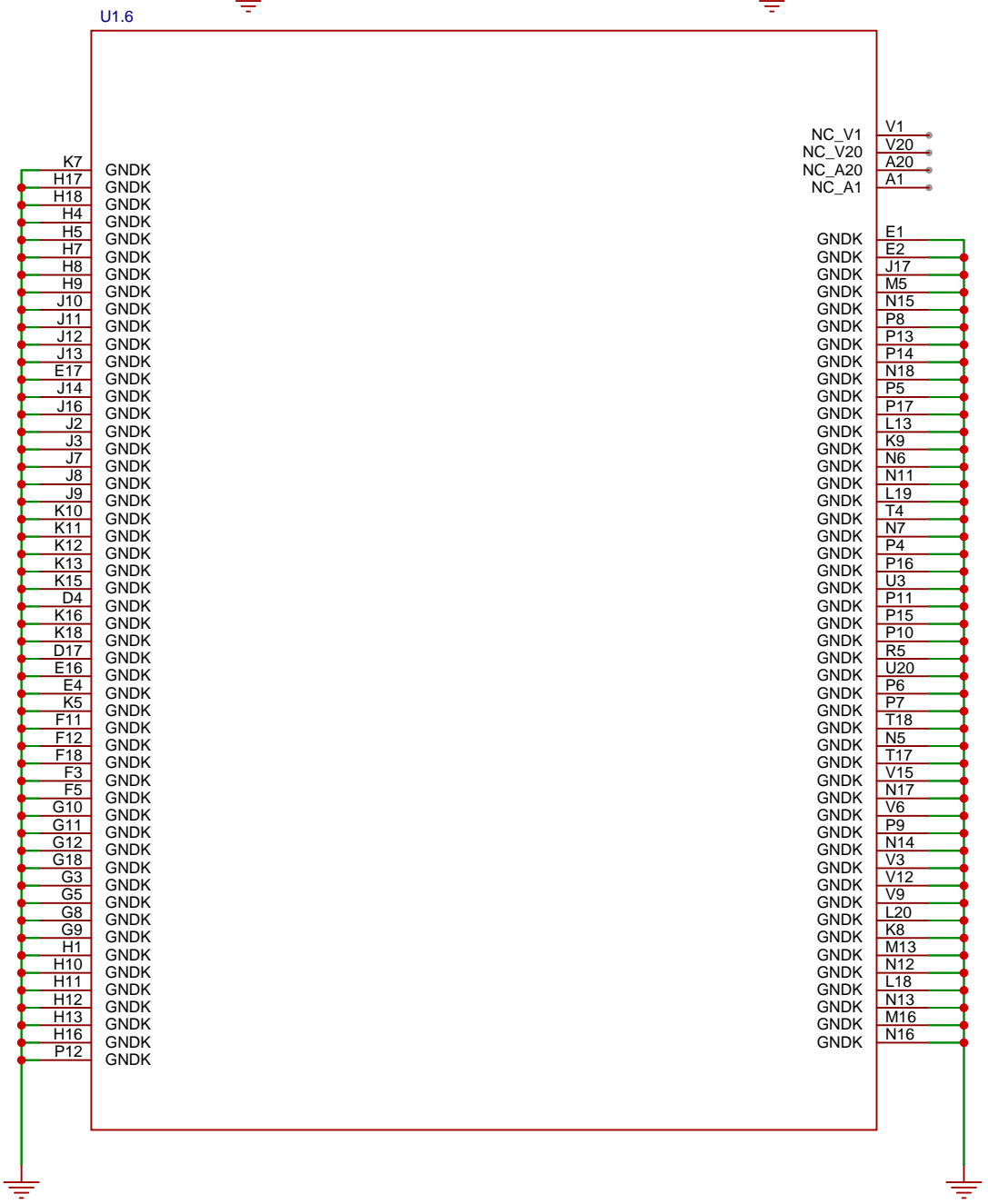
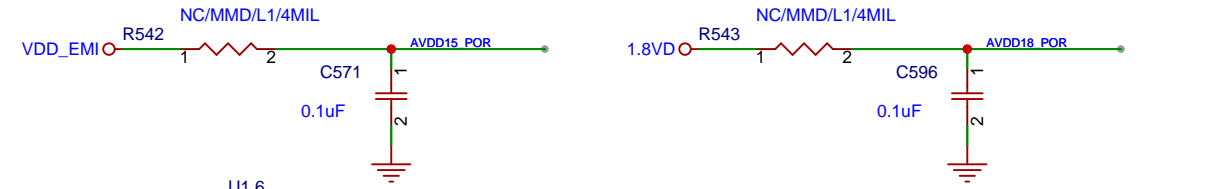
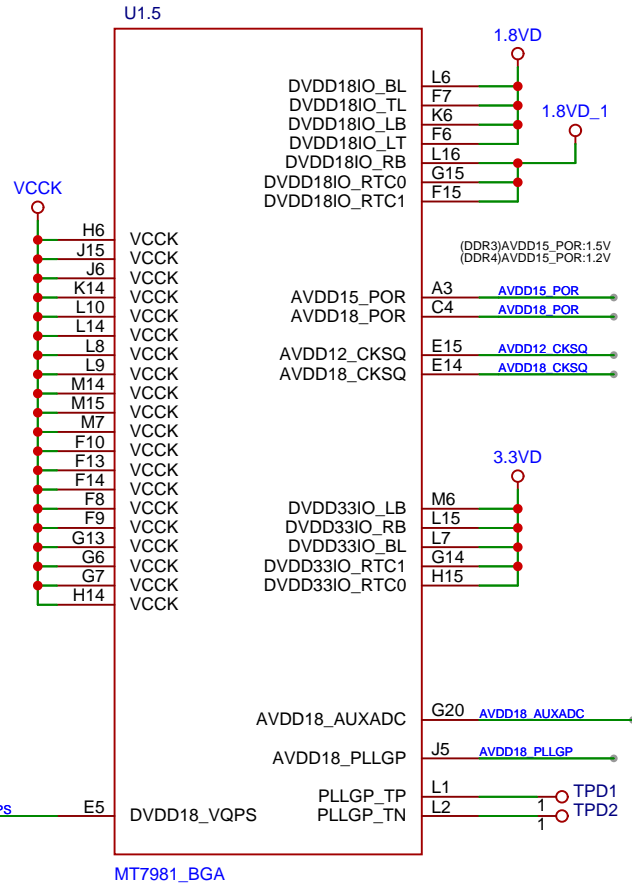
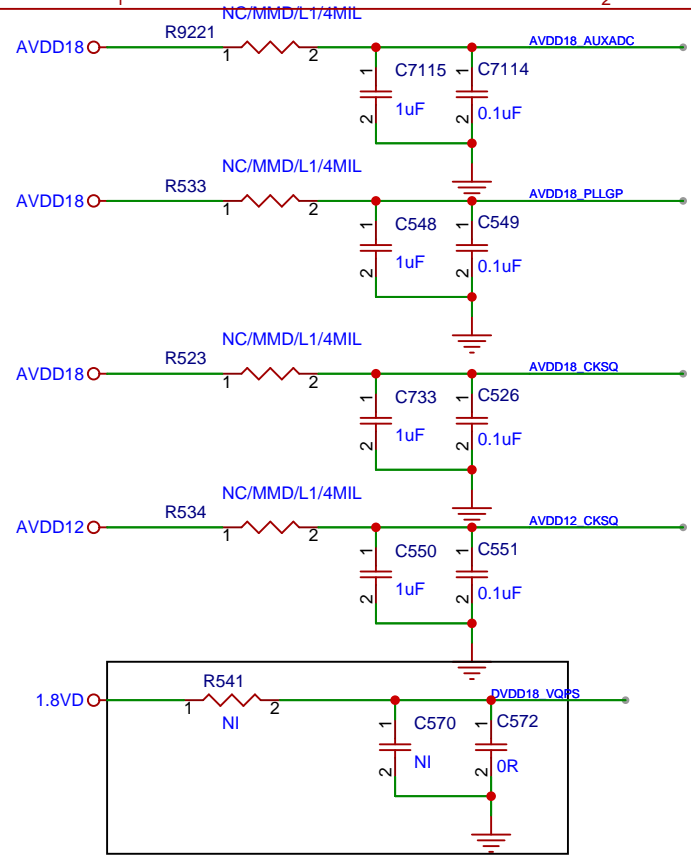

efuse write	rBOM
Yes	R541=0ohm,C572=1uF,C570=0.1uF
NO	R541=NI, C570=NI, C572=0ohm

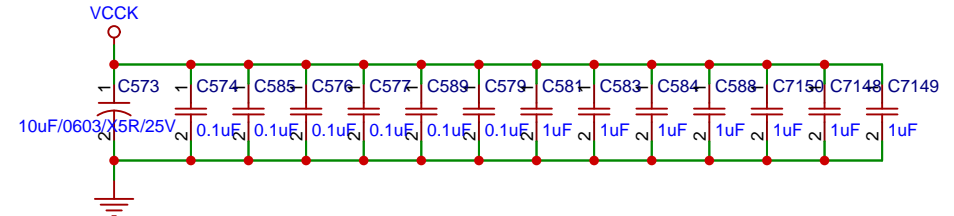
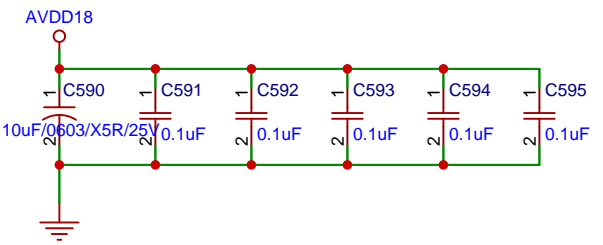
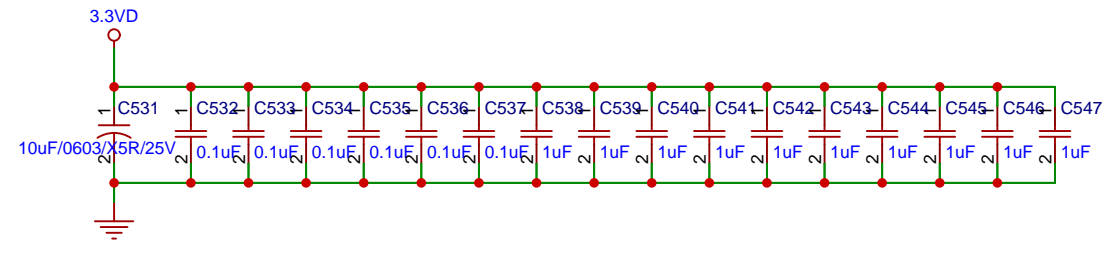
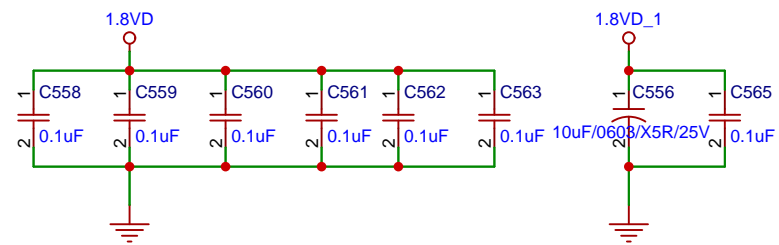



WF0\_2G\_iPAiLNA

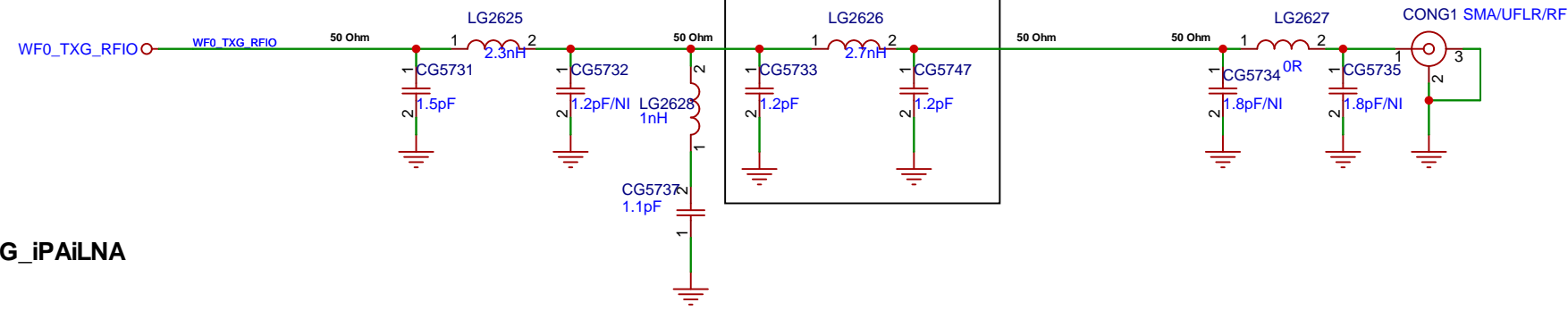

WF1\_2G\_iPAiLNA

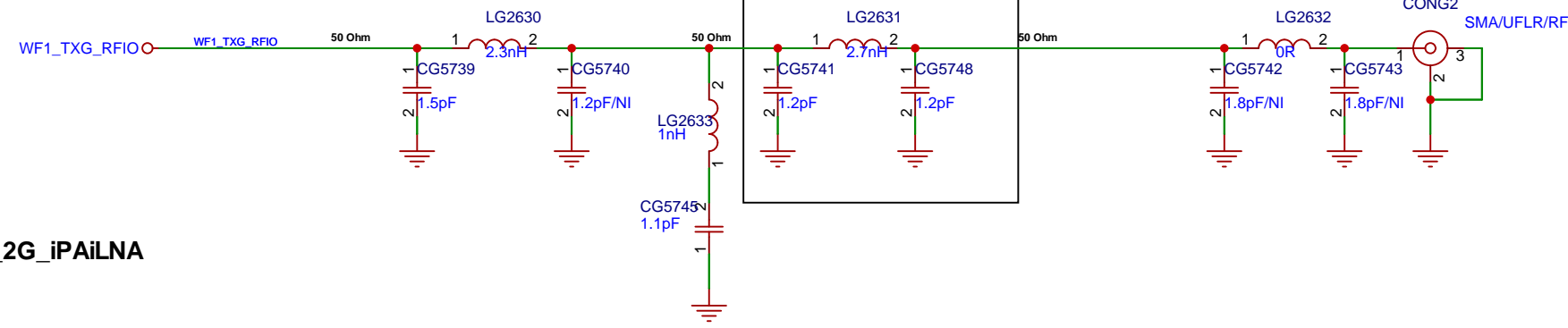

WF2\_5G\_iPAiLNA

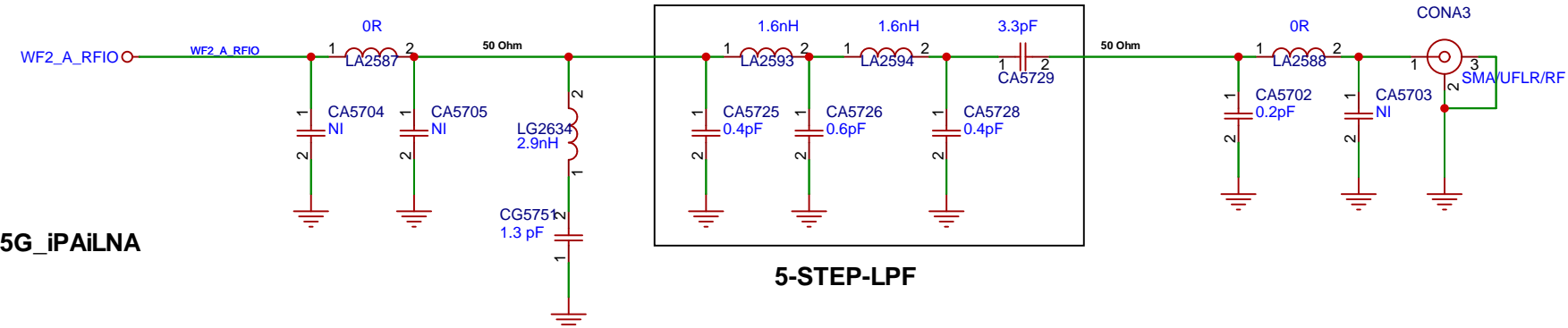

WF3\_5G\_iPAiLNA

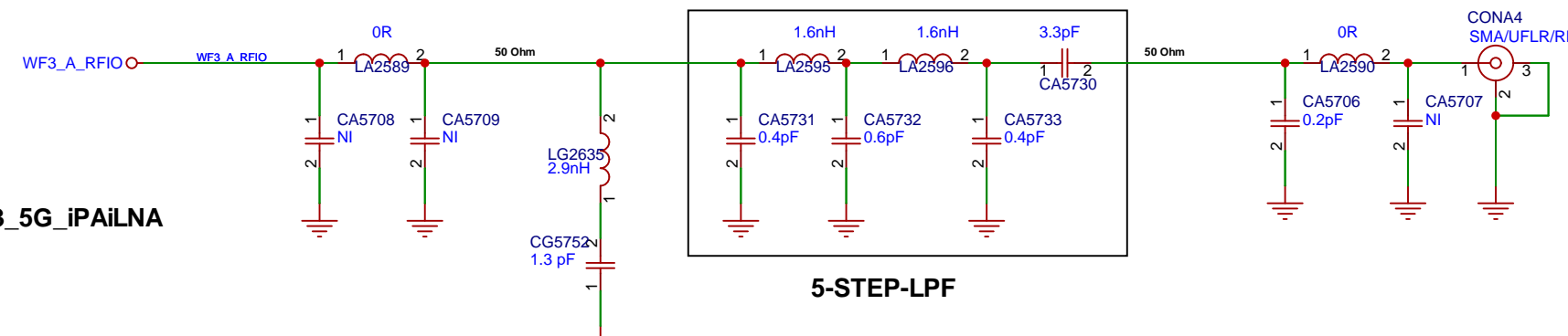

WF4\_5G\_iPAiLNA

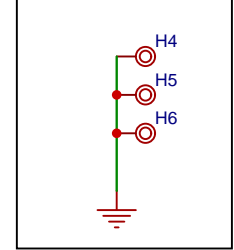
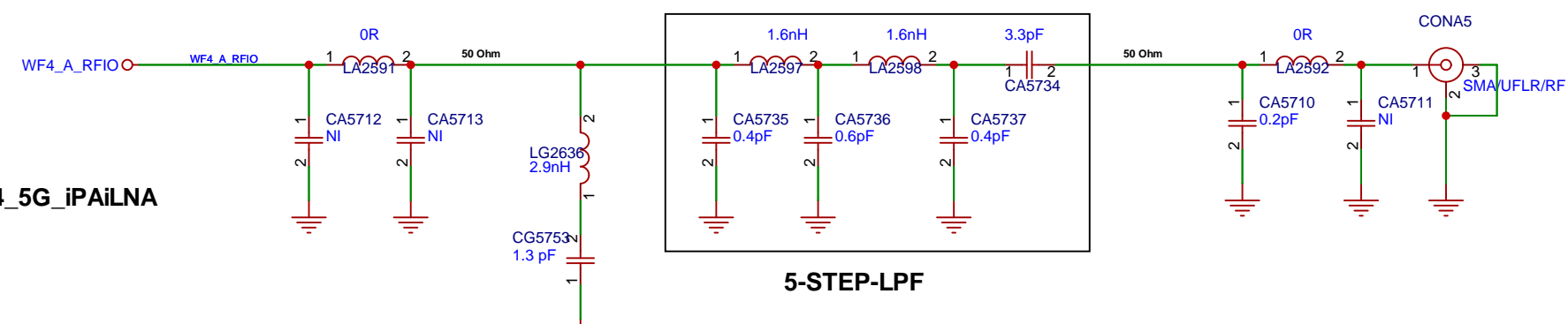

Shielding frame Hole

MediaTek Confidential

MediaTek Inc.		No. 1, Daxing Rd., Hsinchu Science Park Hsinchu, Taiwan 300, R.O.C.		TEL: +886-3-567-0766 Fax: +886-3-578-7610	
Title: 06_MT7976C_RF_IPA_2.4G/5G					
Size: C	Document Number: MT7981 RFB	Drawn: SA2	Rev: V12		
Date:		Sheet: 6	of 12		

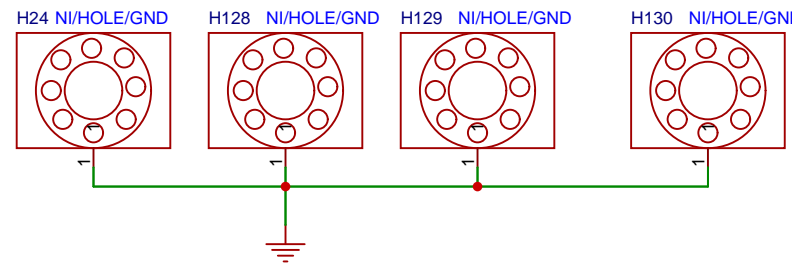
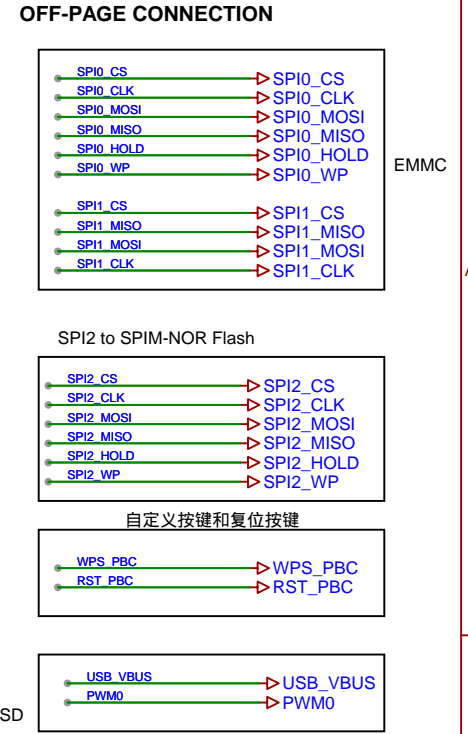
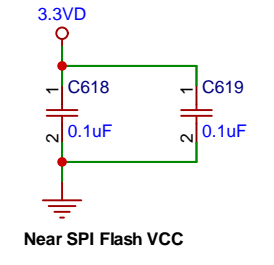
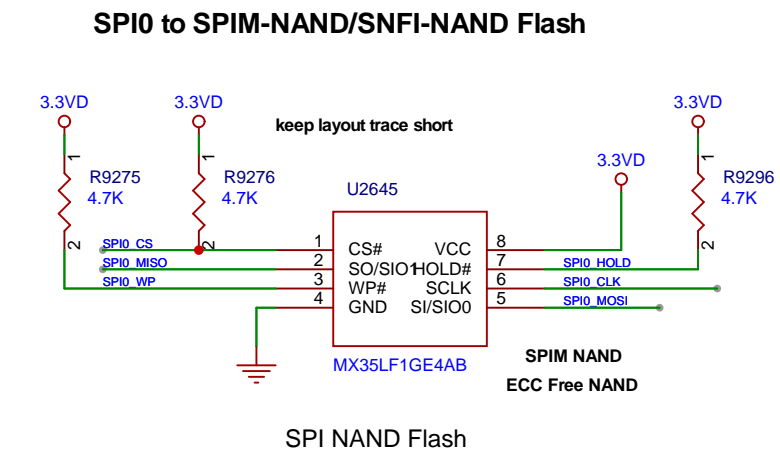
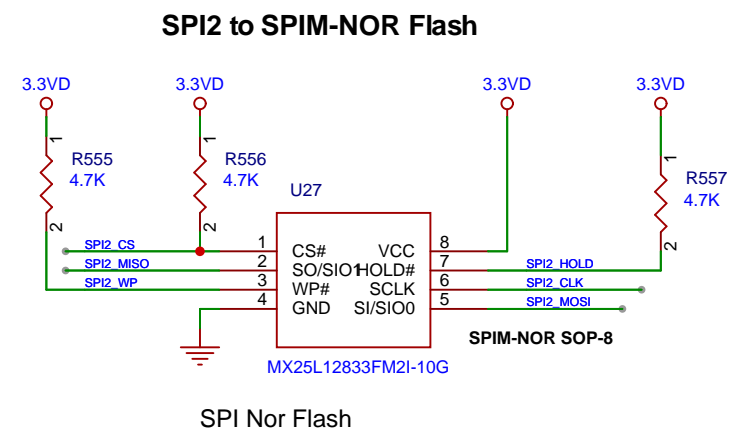
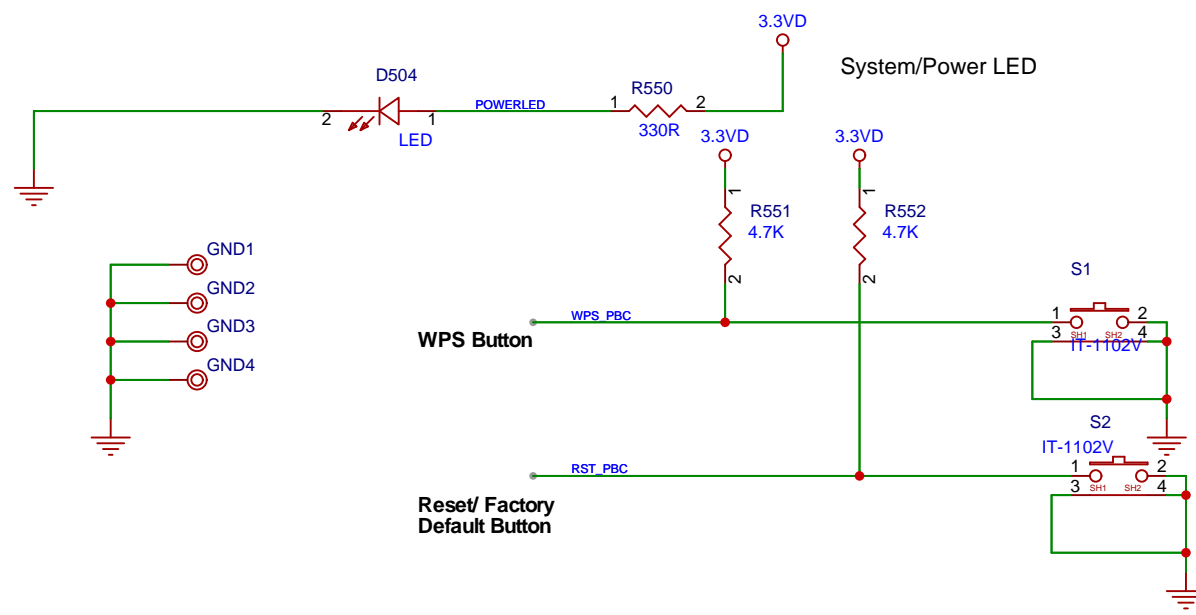

Boot mode Jumper/Layout TXT indicate table

Boot Strapping Pin Name	Description	Boot Sequence
(PWM0, USB_VBUS)	Boot mode	00: SPI-NOR 01: SPI-NAND==>SD 10: eMMC 11: SNAND(SNFI)==>SD
SPI2_CLK	40MHz Xtal select	1 : 40MHz

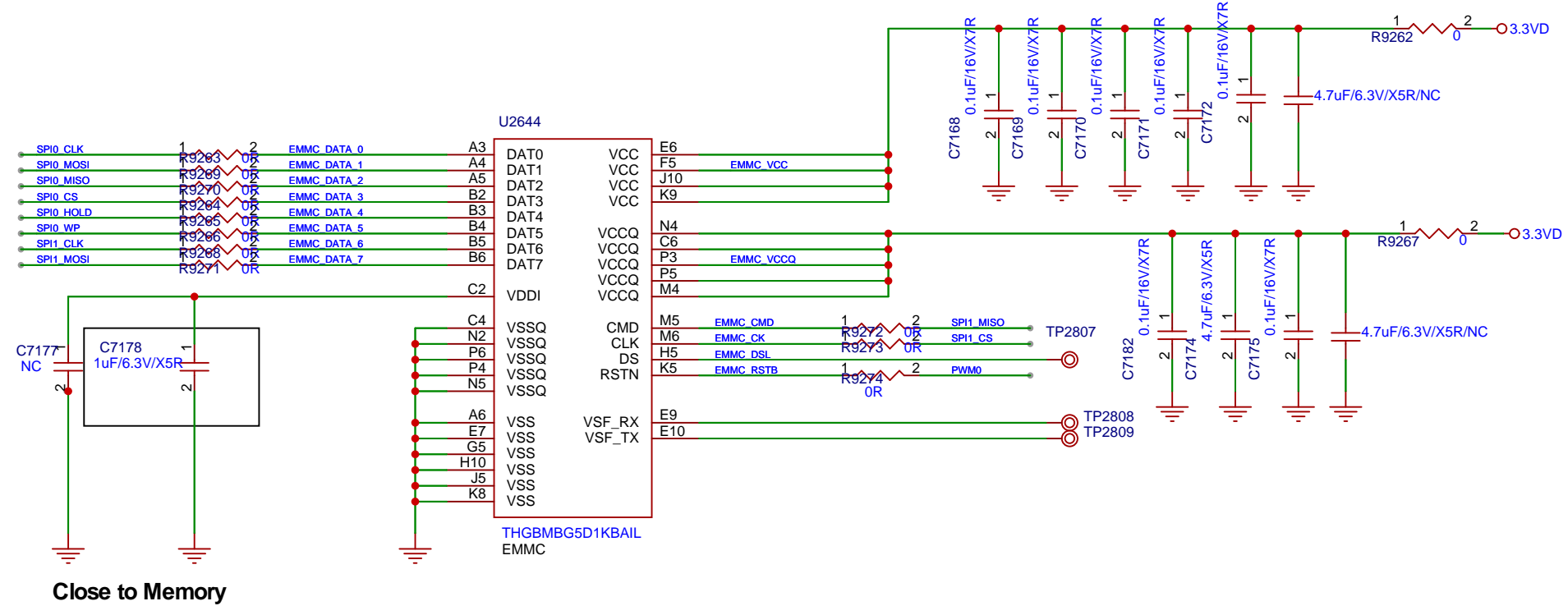
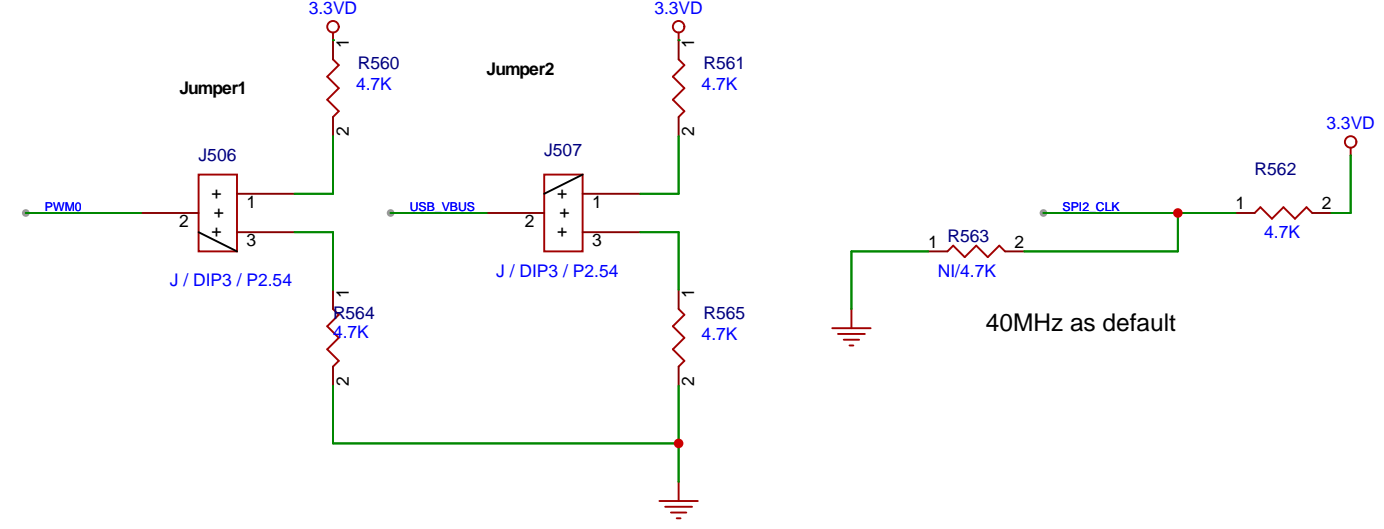

Close to Memory

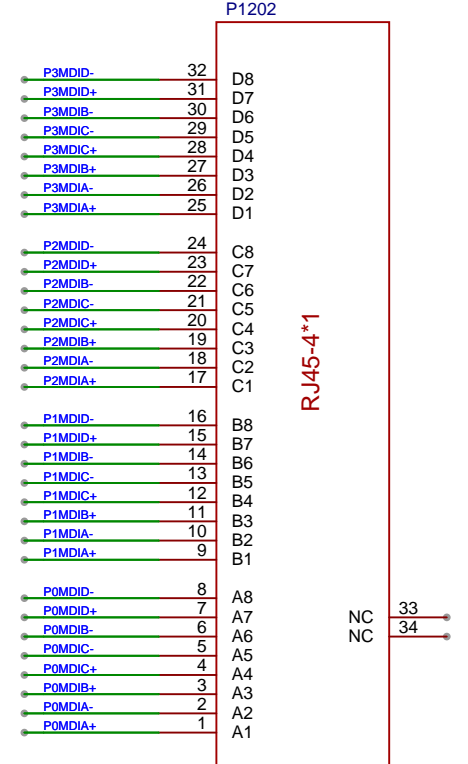
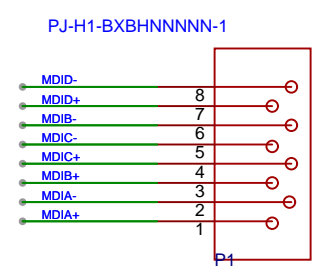
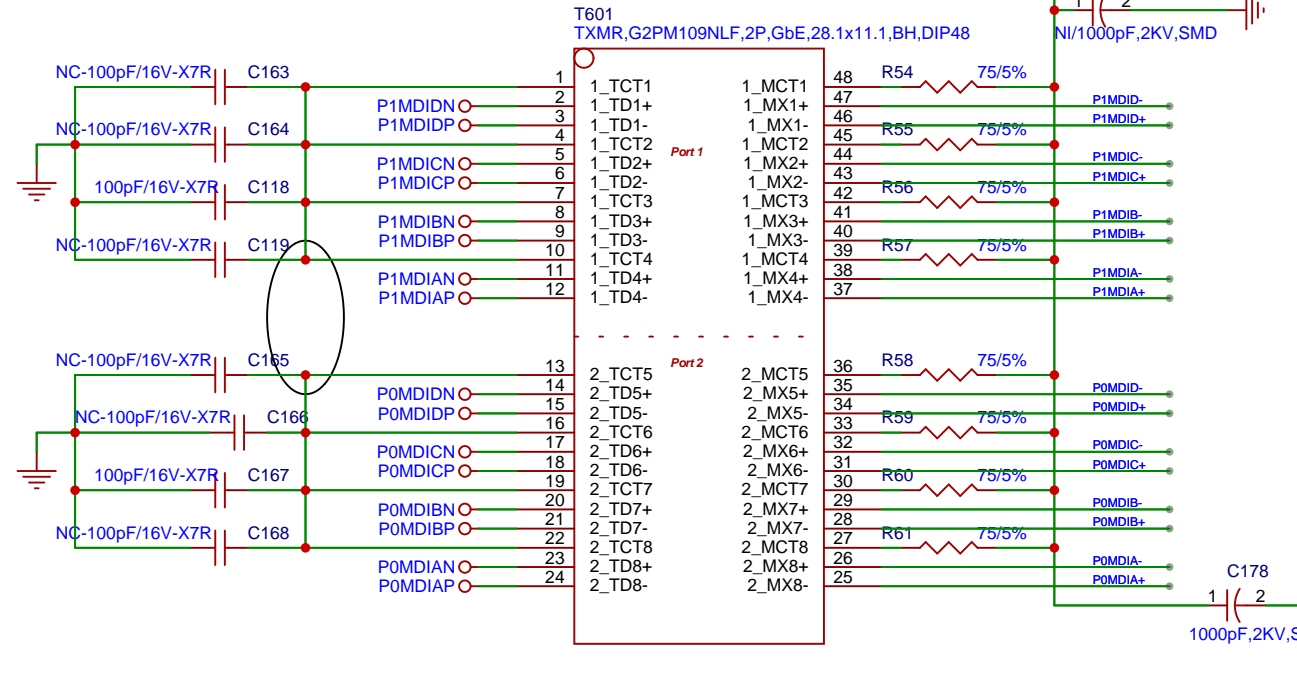
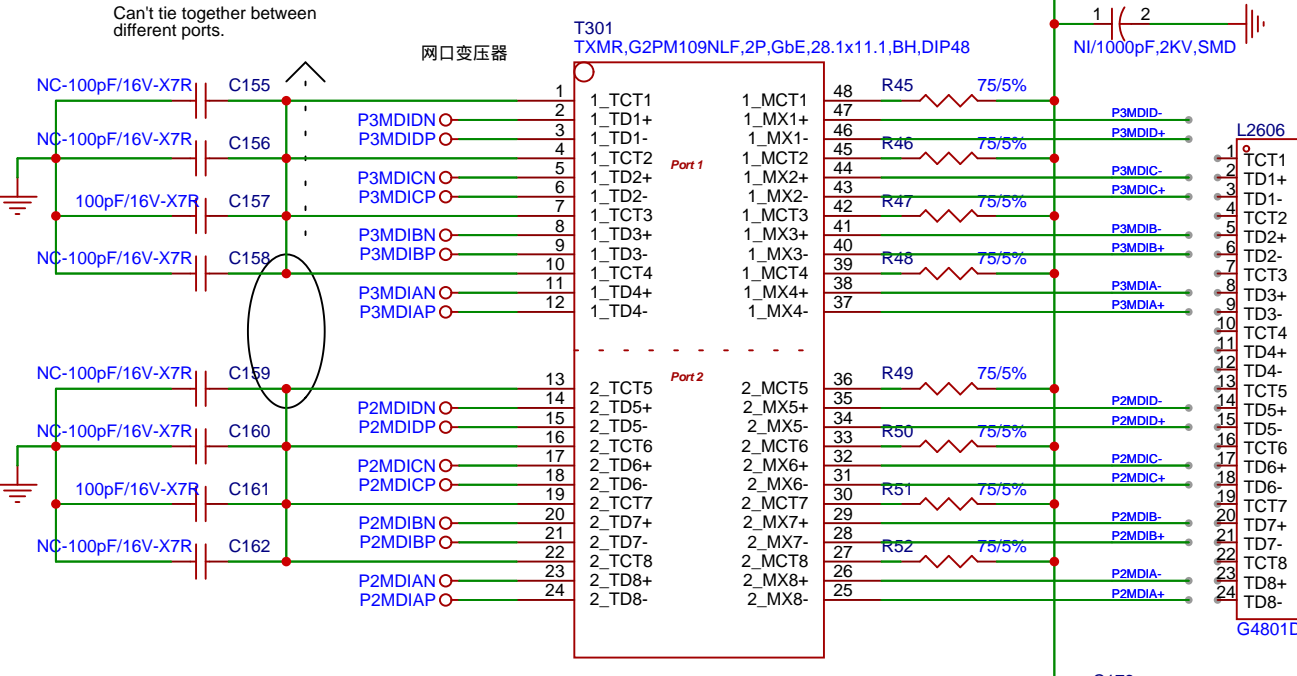
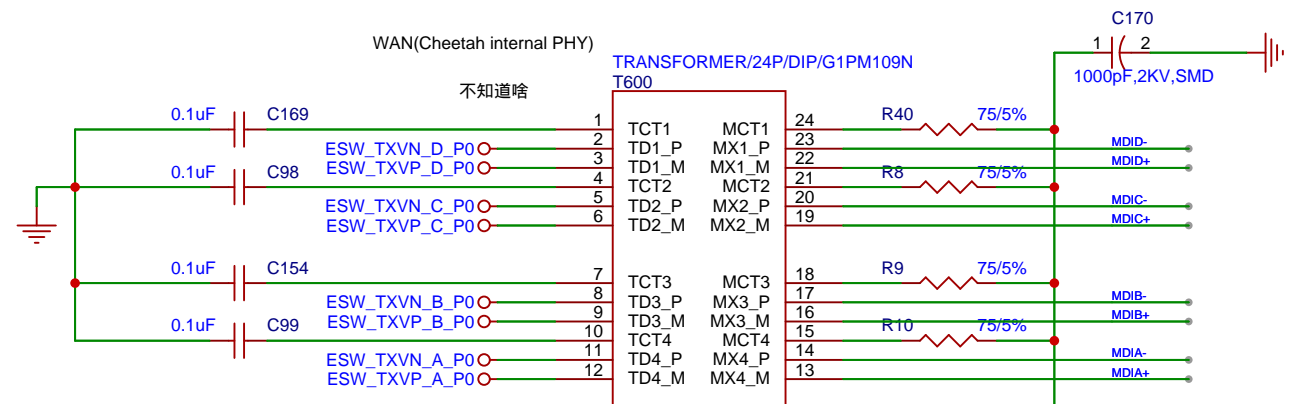

Port 0 LED

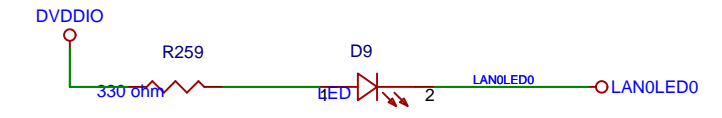

Port 1 LED

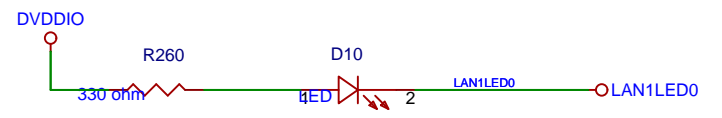

PHY\_EN - Enable Embedded PHY:  
\*\*Pull Up : Enable (default)

Port 2 LED

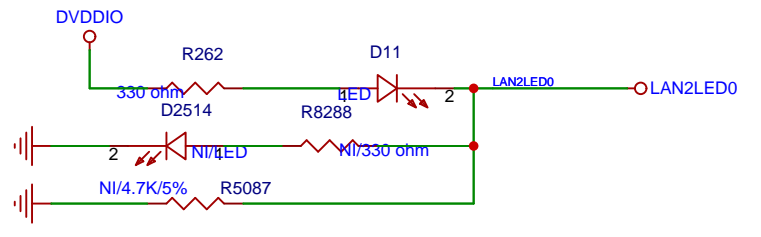

Port 3 LED

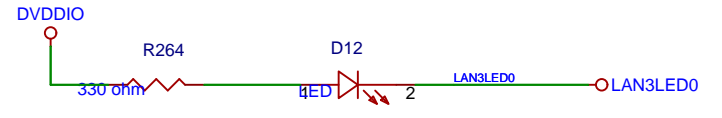

Port 4 LED

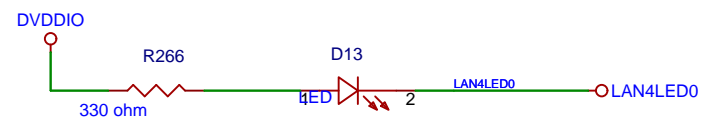

EEP\_MODE - EEPROM mode selection  
\*\*Pull up: EEPROM size greater than 16Kbits (24C32 24C256) (default)  
Pull down:EEPROM size less than or equal 16Kbits (24C02 24C16)

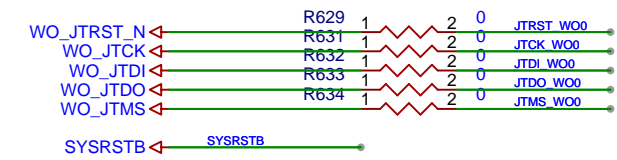
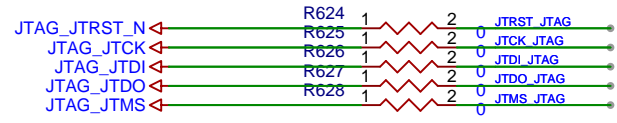

default- JTAG\_CA53  
sw config for WM0

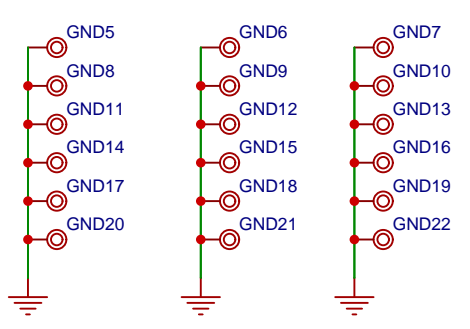

default- JTAG\_WO0  
sw config for WM1/WO1

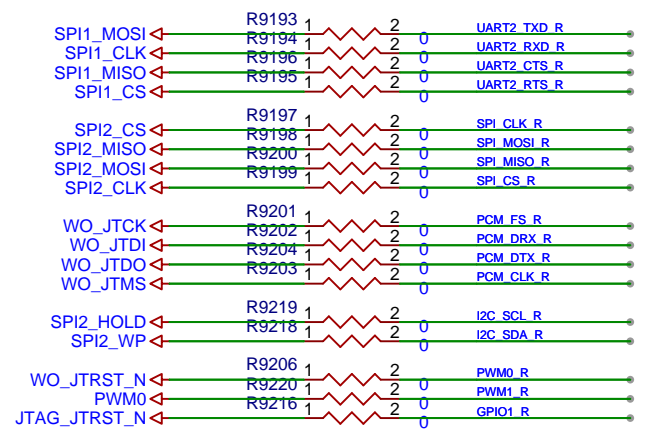
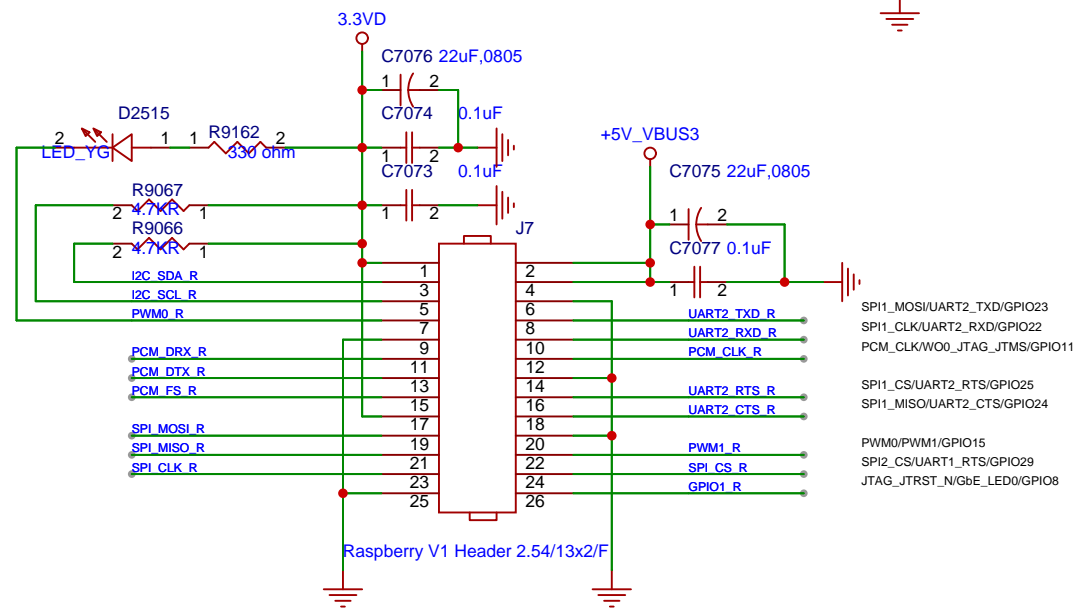
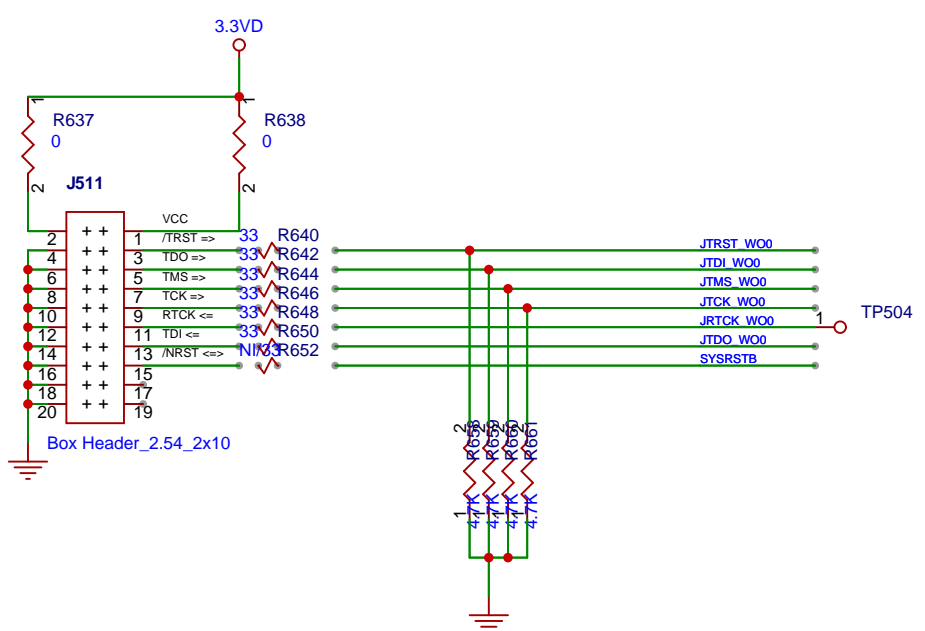
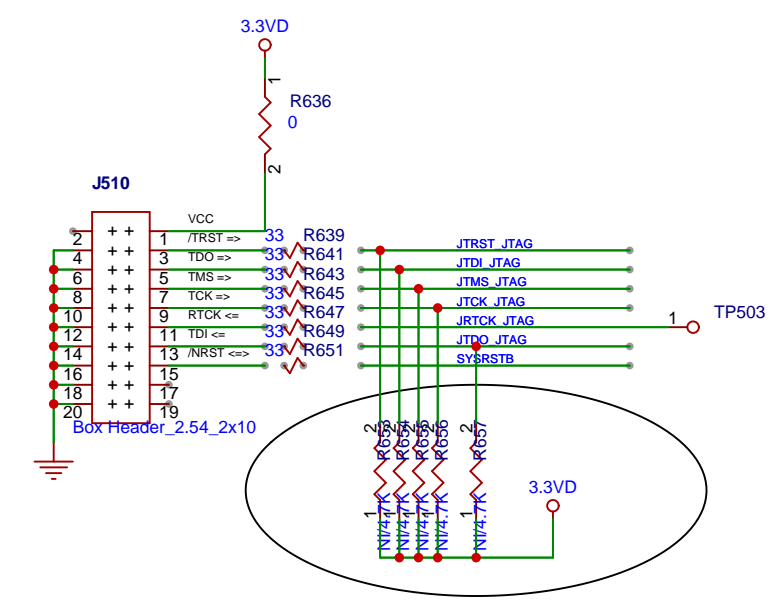
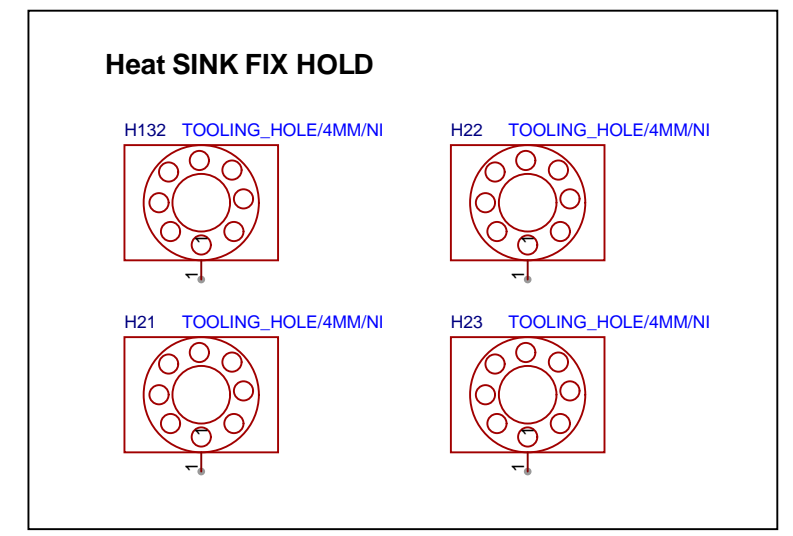

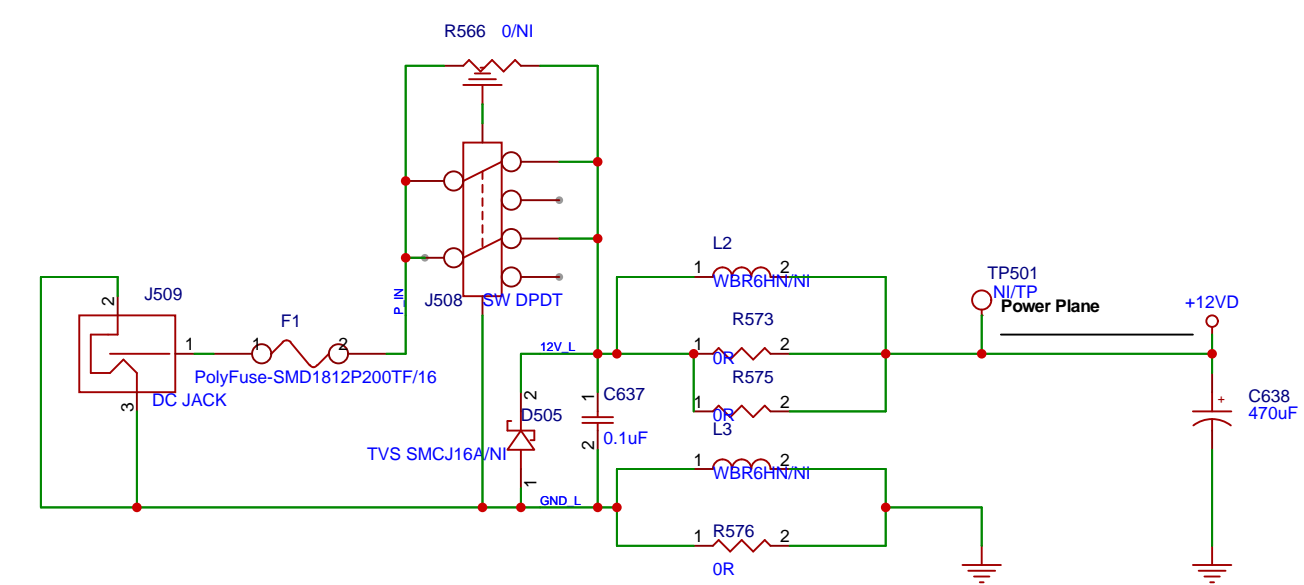
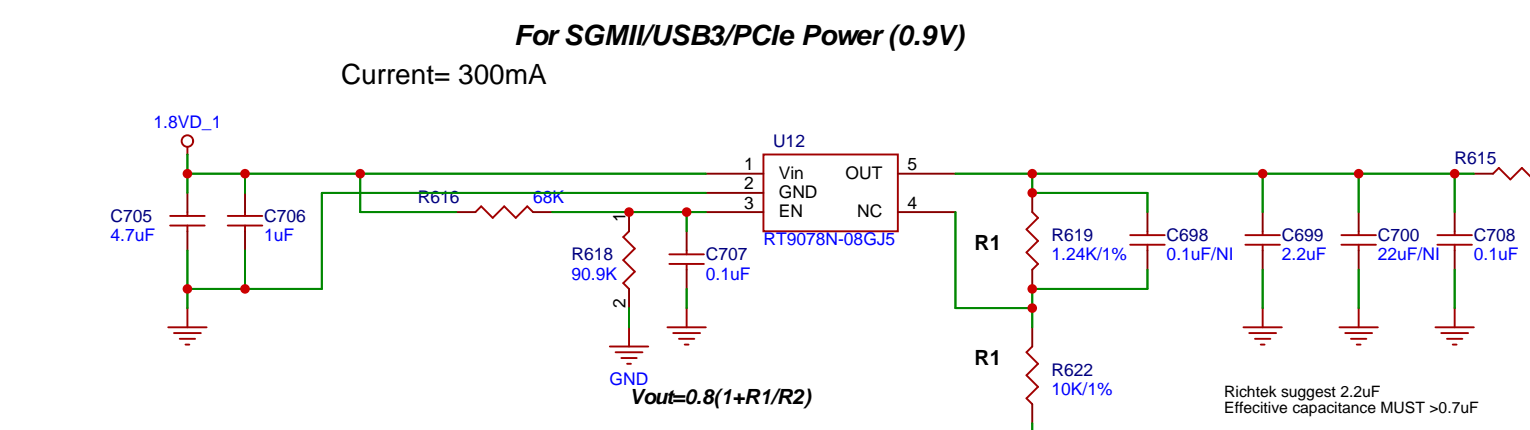
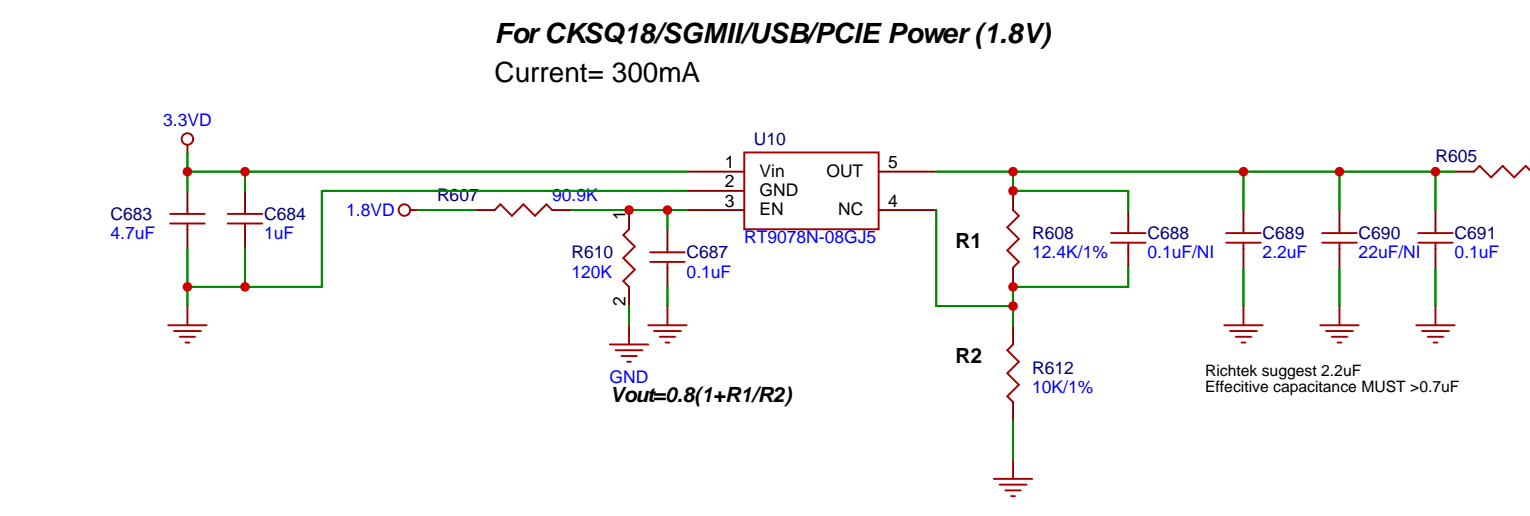
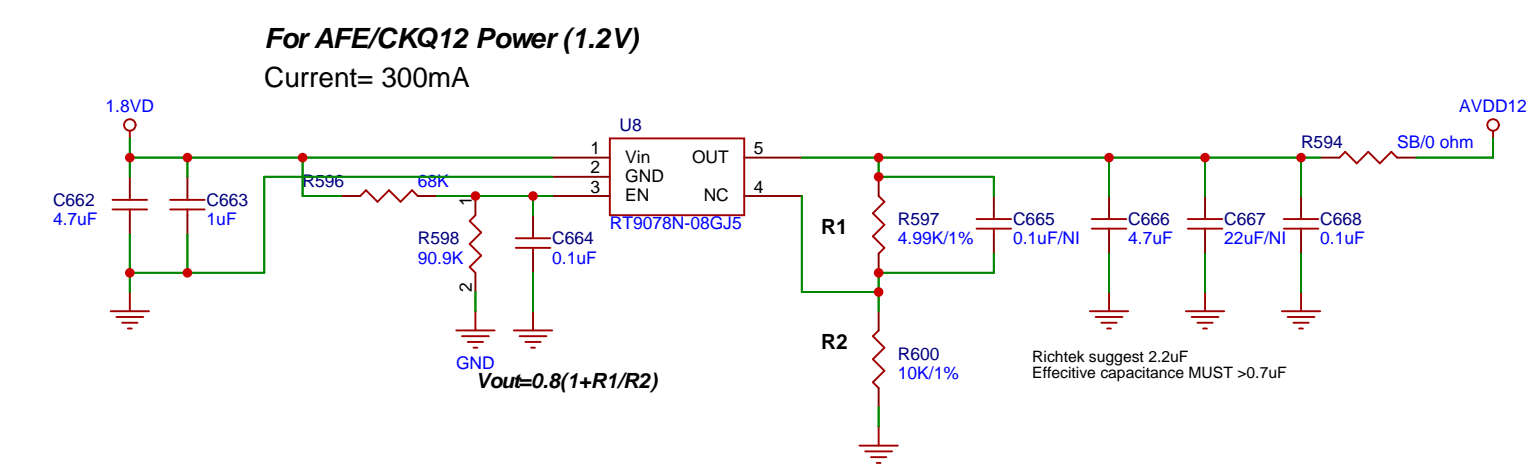
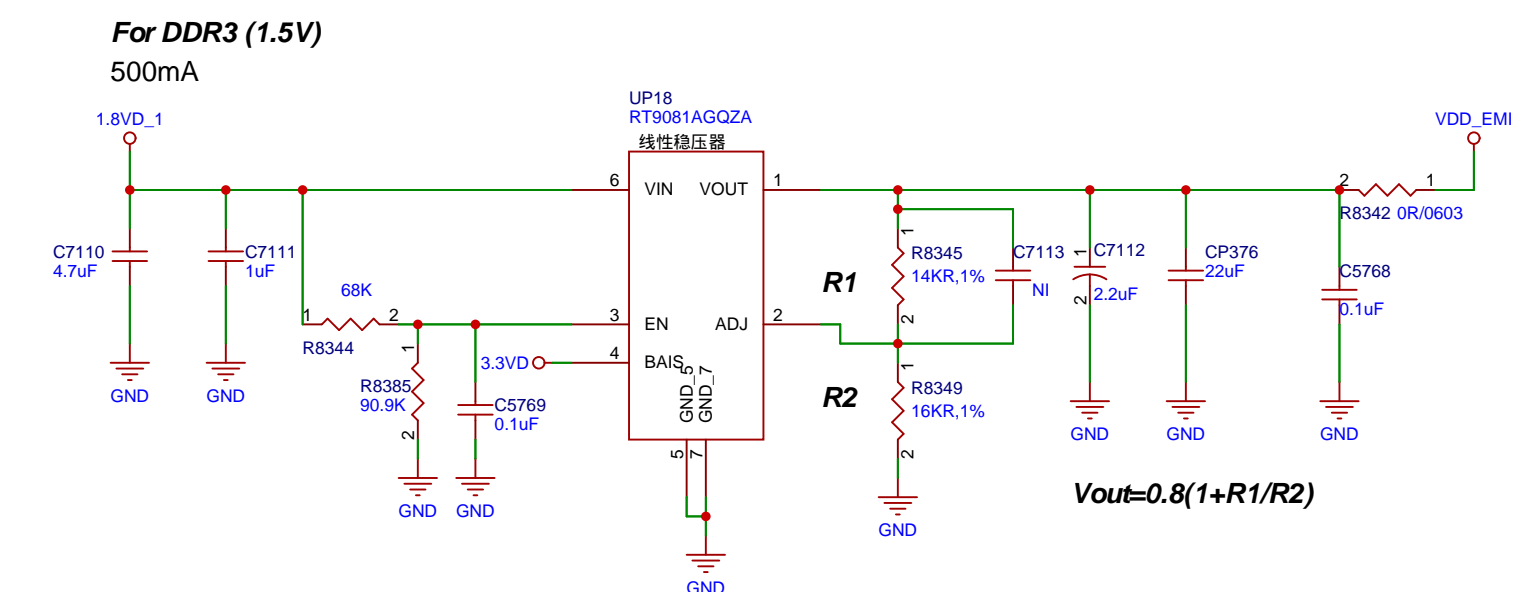
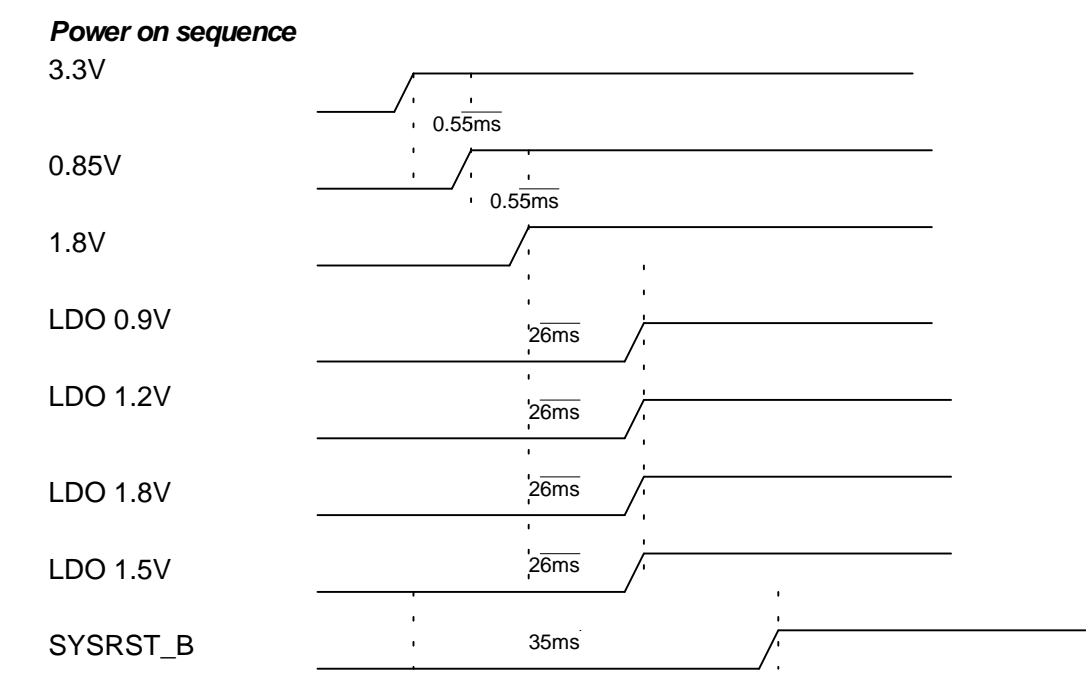
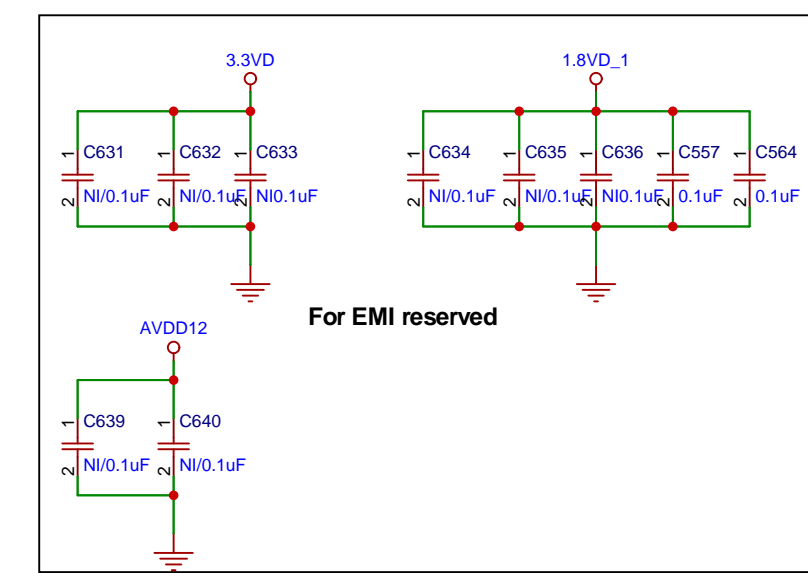
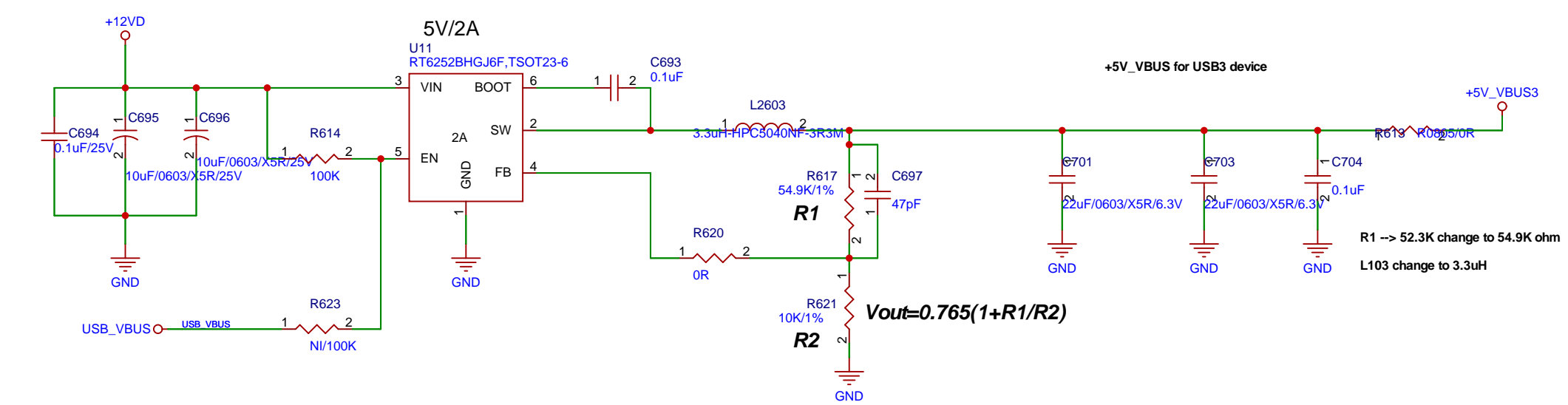
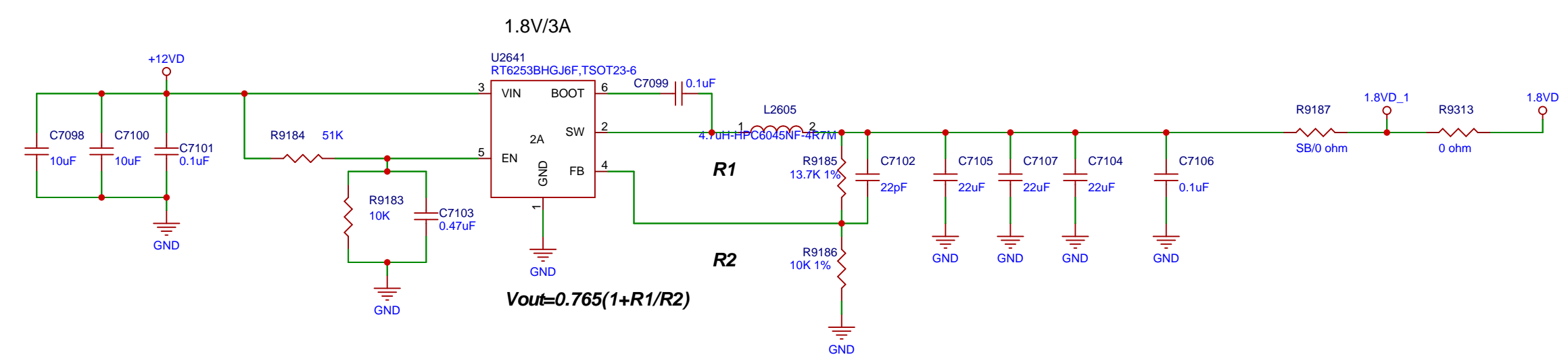
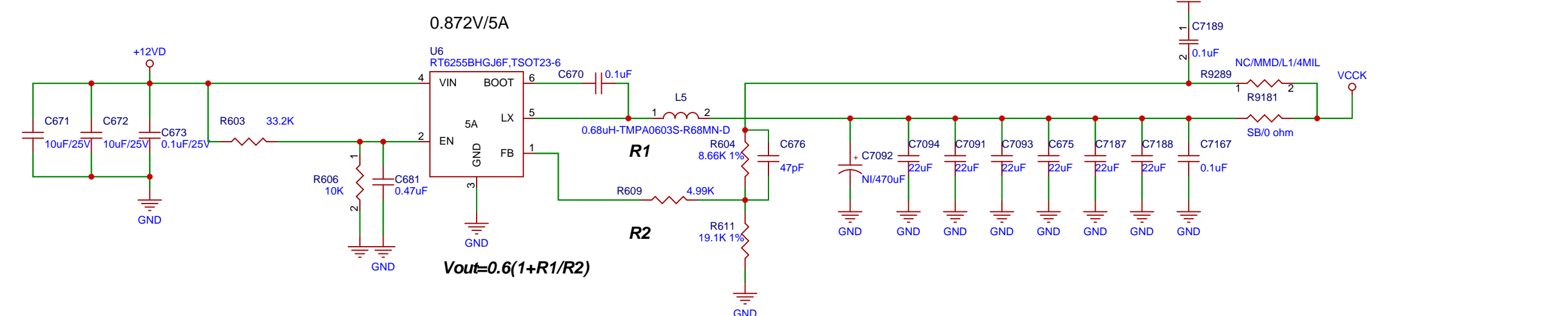
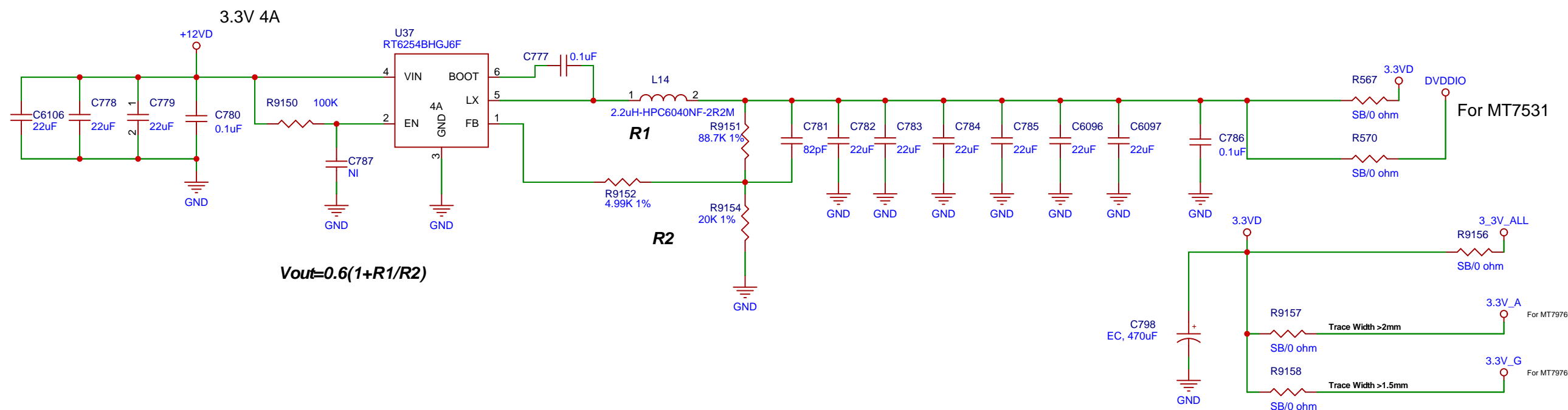

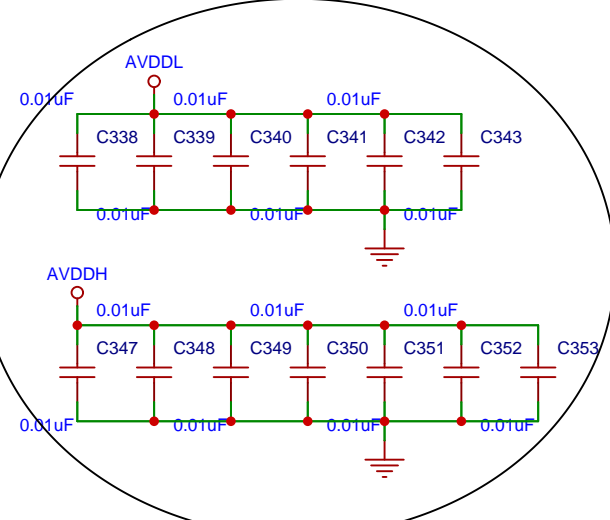
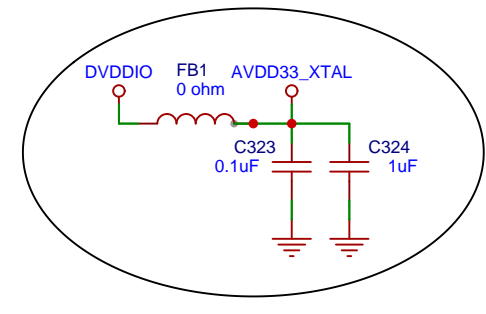
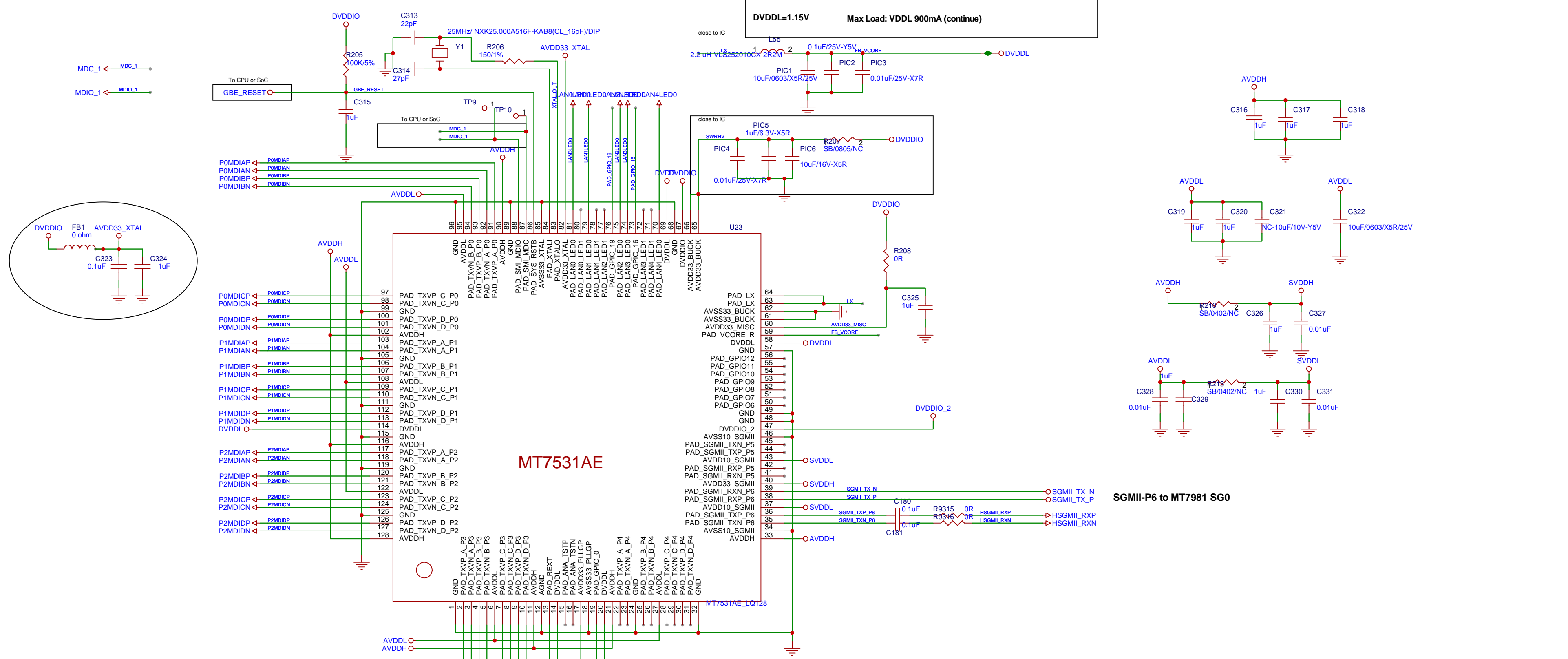

EN\_PWRLIGHT:  
 Pull High: Enable LED Light when Power On or Reset  
 Pull Low: Disable LED Light when Power On or Reset

TM\_DIS - Test Mode Strap  
 Pull Up - Disable (default)

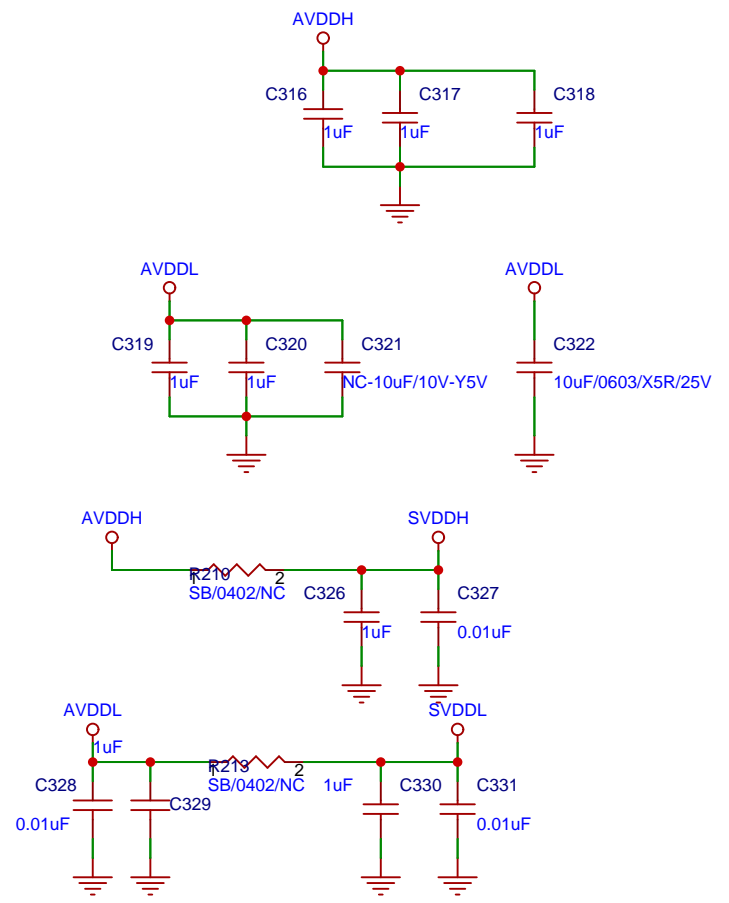

SGMII-P6 to MT7981 SGO

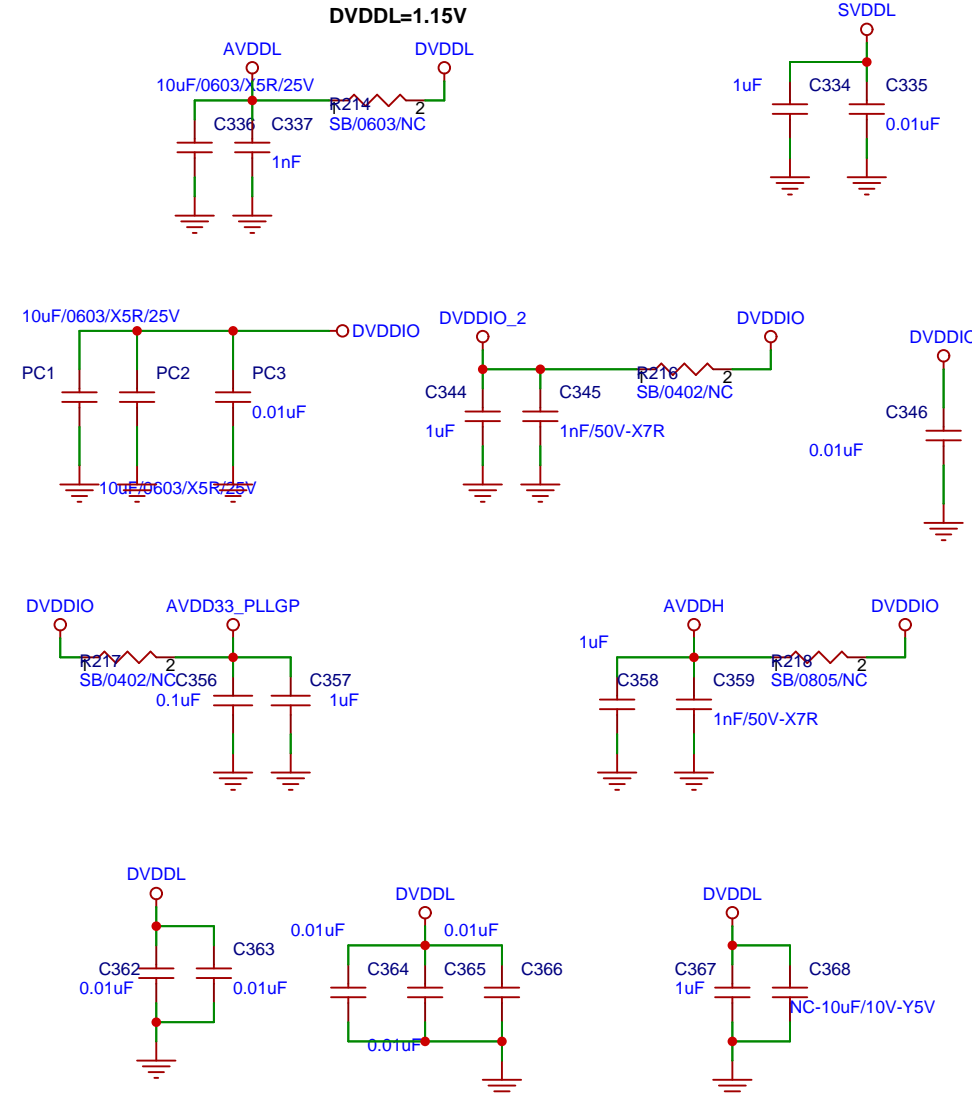

DISAUTOLOAD (when TM\_DIS=1)  
 Pull High: Disable Auto-load EEPROM.

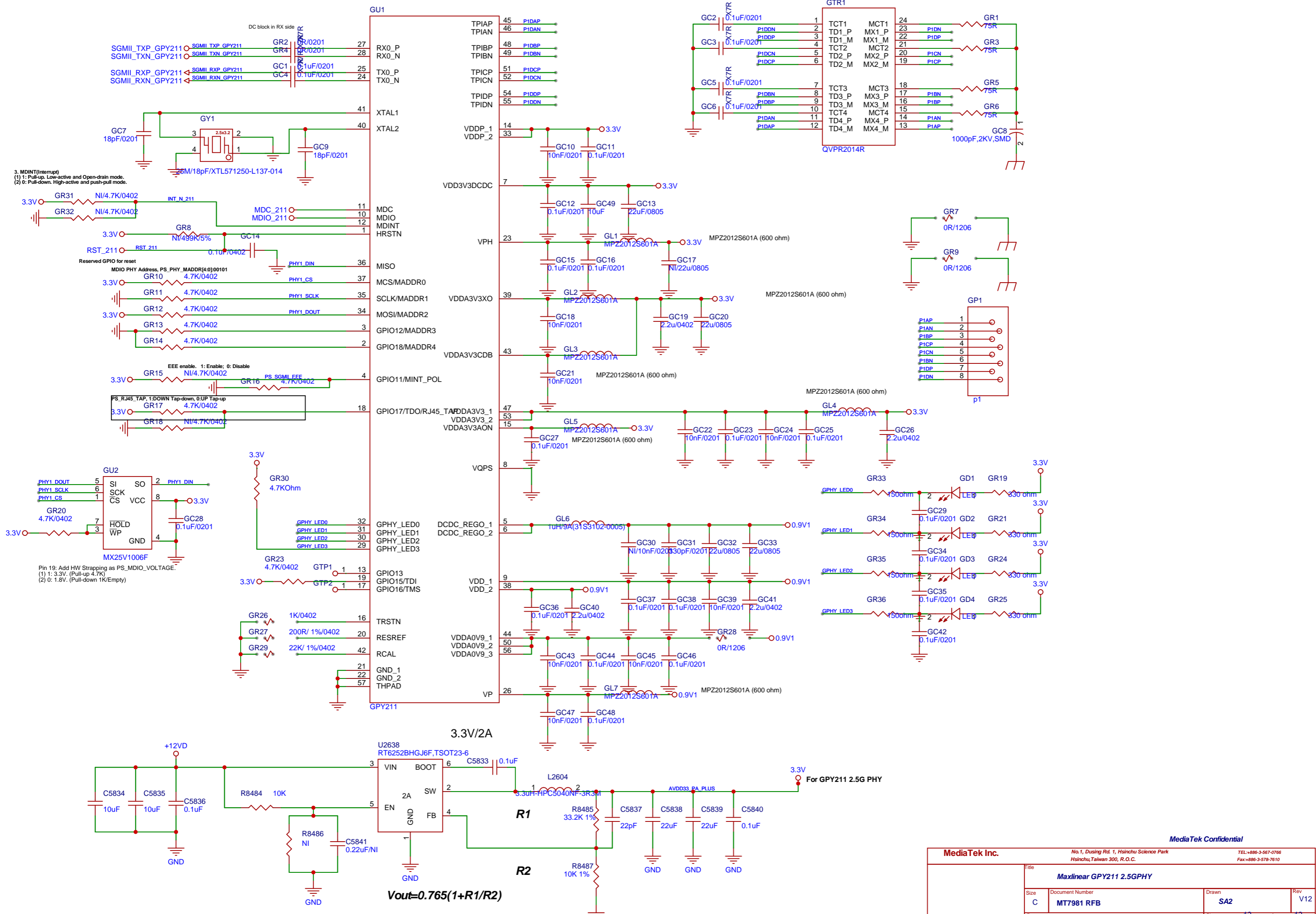

3. MDINT(Interrupt)  
 (1) 1: Pull-up, Low-active and Open-drain mode.  
 (2) 0: Pull-down, High-active and push-pull mode.

Pin 19: Add HW Strapping as PS\_MDIO\_VOLTAGE.  
 (1) 1: 3.3V. (Pull-up 4.7K)  
 (2) 0: 1.8V. (Pull-down 1K/Empty)

MediaTek Confidential

MediaTek Inc.		No. 1, Dusing Rd. 1, Hsinchu Science Park Hsinchu, Taiwan 300, R.O.C.		TEL:+886-3-567-0766 Fax:+886-3-576-7610	
Title: <b>Maxlinear GPY211 2.5GPHY</b>					
Size: <b>C</b>	Document Number: <b>MT7981 RFB</b>	Drawn: <b>SA2</b>	Rev: <b>V12</b>	Date:	
Sheet: <b>12</b>			of: <b>12</b>		