

Features

Processor

- Octa-core ARM Cortex™-A55, up to 2.0 GHz
- RISC-V CPU, up to 200 MHz
- ARM G57 MC01 GPU

Memory

- 32-bit DDR3/DDR3L/LPDDR3/DDR4/LPDDR4/LPDDR4X interface, supporting maximum capacity of 4 GB
- 4 chip select lines for LPDDR3, LPDDR4, and LPDDR4X (especially the 64-bit LPDDR3, LPDDR4, and LPDDR4X)
- SD3.0/eMMC5.1 interface

Video Engine

- H.265 MP and VP9 decoder up to 4K@60fps
- H.264 BL/MP/HP decoder up to 4K@30fps
- H.264 BP/MP/HP encoder up to 4K@25fps
- MJPEG encoder up to 4K@15fps, JPEG encoder up to 8K x 8K resolution

Video Output

- LVDS interface with dual link, up to 1080p@60fps
- One RGB interface with DE/SYNC mode, up to 1080p@60fps
- eDP 1.3, up to 2.5K@60fps
- 4+4-lane MIPI-DSI output interface up to 2.5K@60fps

Video Input

- 4+4-lane, 4+2+2-lane, or 2+2+2+2-lane MIPI CSI, up to 2.0 Gbit/s per lane in HS transmission, compliant with MIPI-CSI2 V1.1 and MIPI DPHY V1.1
- Maximum video capture resolution of 8M@30fps

Audio

- 2 DACs and 3 ADCs
- 3 x audio outputs: LINEOUTLP/N, LINEOUTRP/N, HPOUTL/R
- 3 x audio inputs: MICIN1P/N, MICIN2P/N, MICIN3P/N
- 4x I2S/PCM external interfaces: I2S0, I2S1, I2S2, and I2S/PCM3
- Maximum 8 digital PDM microphones (DMIC)
- One OWA RX and one OWA TX, compliance with S/PDIF interface

External Peripherals

- 1 x USB2.0 Host, 1 x USB2.0 DRD, 1 x USB3.1 DRD&PCIe2.1 Combo
- 1 x GMAC (10/100/1000 Mbps port with RGMII and RMII interfaces)
- 2 x CIR RX, 1 x CIR TX, 9 x TWI, 4 x SPI, 10 x UART
- 30-ch PWM, 4-ch GPADC, 2-ch LRADC
- SDIO 3.0, LEDC, SPIF (Octal I/O)

Security System

- AES, DES, 3DES, and SM4 encryption and decryption algorithms
- MD5, SHA, and HMAC tamper proofing
- RSA, ECC signature and verification algorithms

Package

- FCCSP 522balls, 15 mm x 15 mm size, 0.5 mm ball pitch, 0.3 mm ball size

Revision History

Revision	Date	Author	Description
1.0	Mar.30, 2023	AWA1896	Initial Release Version
1.0.1	May 12, 2023	AWA1896	Update the performance of video decoding.
1.1	Jul. 5, 2023	AWA1896	<p>Cover page Update some features of the following modules: memory, video engine, video input, audio, and external peripherals.</p> <p>About This Document Add revision number definition.</p> <p>Chapter 1 Overview Update overview.</p> <p>Chapter 2 Ordering Information Add A523H00X0000 and update device information.</p> <p>Chapter 3 Features Update the features of some modules.</p> <p>Chapter 4 Block Diagram Update the block diagram in Figure 4-1.</p> <p>Chapter 5 Pin Description Update some pin characteristics and signal descriptions.</p> <p>Chapter 6 Electrical Characteristics Update some electrical characteristics and interface timings.</p> <p>Chapter 9 Carrier, Storage and Backing Information Update tray dimension.</p> <p>Chapter 12 Part Marking Add A523H00X0000 marking information.</p>

Contents

A523.....	i
Revision History	i
Contents	ii
Figures	viii
Tables	x
About This Document	14
1 Overview	16
2 Ordering Information	16
3 Features	17
3.1 CPU Architecture	17
3.2 GPU Architecture	17
3.3 Memory Subsystem	17
3.3.1 Boot ROM (BROM)	17
3.3.2 RAW NAND Flash	18
3.3.3 SDRAM	18
3.3.4 SMHC	18
3.4 Video and Graphics	19
3.4.1 Display Engine (DE)	19
3.4.2 De-interlacer (DI)	20
3.4.3 Graphic 2D (G2D)	20
3.4.4 Video Engine	20
3.5 Video Output	21
3.5.1 eDP1.3	21
3.5.2 MIPI DSI	22
3.5.3 TCON LCD	22
3.5.4 TCON TV	23
3.6 Video Input	23
3.6.1 ISP	23
3.6.2 VIPP	23

3.6.3	MIPI CSI	24
3.6.4	Parallel CSI	24
3.7	System Peripherals	24
3.7.1	Clock Controller Unit (CCU)	24
3.7.2	DMAC	24
3.7.3	I/O Memory Management Unit (IOMMU)	25
3.7.4	Message Box (MSGBOX)	25
3.7.5	Power Reset Clock Management (PRCM)	26
3.7.6	RTC	26
3.7.7	Spinlock	26
3.7.8	Thermal Sensor Controller (THS)	26
3.7.9	Timer	26
3.7.10	Watchdog Timer (WDT)	27
3.8	Audio Subsystem	27
3.8.1	Audio Codec	27
3.8.2	I2S/PCM	28
3.8.3	DMIC	28
3.8.4	One Wire Audio (OWA)	28
3.9	Security System	29
3.9.1	Crypto Engine (CE)	29
3.9.2	Security ID (SID)	30
3.9.3	Secure Memory Control (SMC)	30
3.9.4	Secure Peripherals Control (SPC)	30
3.10	External Peripherals	30
3.10.1	CIR Receiver (CIR_RX)	30
3.10.2	CIR Transmitter (CIR_TX)	31
3.10.3	GAMC	31
3.10.4	General Purpose ADC (GPADC)	31
3.10.5	LEDC	32
3.10.6	Low Rate ADC (LRADC)	32
3.10.7	USB2.0 DRD	32
3.10.8	USB2.0 HOST	33

3.10.9	PCIe2.1&USB3.1 System	33
3.10.10	PWM	35
3.10.11	SPI and SPI_DBI	36
3.10.12	SPI Flash Controller (SPIFC)	37
3.10.13	Two Wire Interface (TWI)	37
3.10.14	UART	38
3.11	Package	38
4	Block Diagram	39
5	Pin Description	41
5.1	Pin Quantity	41
5.2	Pin Characteristics	41
5.2.1	SDRAM	42
5.2.2	System	45
5.2.3	RTC&PLL	45
5.2.4	DCXO	45
5.2.5	USB2.0 DRD	46
5.2.6	USB2.0 Host	46
5.2.7	PCIe2.1&USB3.1 DRD	46
5.2.8	eDP1.3	47
5.2.9	Audio Codec	47
5.2.10	GPADC	48
5.2.11	LRADC	49
5.2.12	Power	49
5.2.13	GPIO Groups	49
5.2.14	Ground	57
5.2.15	Others	57
5.3	GPIO Multiplex Function	57
5.3.1	Port B	57
5.3.2	Port C	57
5.3.3	Port D	58
5.3.4	Port E	58
5.3.5	Port F	59

5.3.6	Port G	59
5.3.7	Port H	59
5.3.8	Port K	60
5.3.9	Port L	61
5.3.10	Port M	61
5.4	Detailed Signal Description	62
5.4.1	Audio Codec	62
5.4.2	CIR_RX	63
5.4.3	CIR_TX	63
5.4.4	DCXO	63
5.4.5	DMIC	64
5.4.6	eDP1.3	64
5.4.7	GMAC	65
5.4.8	GPADC	65
5.4.9	I2S/PCM	66
5.4.10	JTAG	67
5.4.11	LEDC	67
5.4.12	LRADC	67
5.4.13	MIPI CSI	67
5.4.14	MIPI DSI	68
5.4.15	RAW NAND Flash	69
5.4.16	OWA	70
5.4.17	Parallel CSI	70
5.4.18	PCIe2.1&USB3.1 DRD	70
5.4.19	PWM	71
5.4.20	RTC&PLL	71
5.4.21	SDRAM	71
5.4.22	SPI&SPI_DBI	72
5.4.23	SPIFC	74
5.4.24	SMHC	74
5.4.25	System	75
5.4.26	TCONLCD	75

5.4.27	TWI	76
5.4.28	USB2.0 DRD	77
5.4.29	USB2.0 Host	77
5.4.30	UART	77
6	Electrical characteristics	79
6.1	Parameter Conditions	79
6.1.1	Minimum and Maximum Values	79
6.1.2	Typical Values	79
6.1.3	Temperature Definitions	79
6.2	Absolute Maximum Ratings	79
6.3	Recommended Operating Conditions	81
6.4	DC Electrical Characteristics	83
6.5	SMHC Electrical Characteristics	85
6.6	GPADC Electrical Characteristics	86
6.7	LRADC Electrical Characteristics	86
6.8	Audio Codec Electrical Characteristics	87
6.9	Clock Electrical Characteristics	89
6.9.1	Input Clock Requirements	89
6.9.2	Output clock characteristics	91
6.10	Internal Reset Electrical Characteristics	91
6.11	Interface Timing	92
6.11.1	RAW NAND Interface Timing	92
6.11.2	SMHC Interface Timing	96
6.11.3	UART Interface Timing	103
6.11.4	SPI Interface Timing	104
6.11.5	SPI-DBI Interface Timing	105
6.11.6	SPI Flash Interface Timing	108
6.11.7	TWI Interface Timing	111
6.11.8	GMAC Interface Timing	112
6.11.9	MIPI DSI Interface Timing	114
6.11.10	I2S/PCM Interface Timing	115
6.11.11	OWA Interface Timing	119

6.12	Power-On and Power-Off Sequence	119
6.12.1	Power-On Sequence	119
6.12.2	Power-Off Sequence	121
7	Temperature and Thermal Characteristics	122
7.1	Temperature	122
7.2	Package Thermal Characteristics	122
8	Pin Assignment	124
8.1	Pin Map	124
8.2	Package Dimension	125
9	Carrier, Storage and Backing Information	126
9.1	Carrier	126
9.2	Storage	127
9.2.1	Moisture Sensitivity Level (MSL)	127
9.2.2	Bagged Storage Conditions	128
9.2.3	Out-of-bag Duration	128
9.3	Baking	128
10	Reflow Profile	130
11	FT/QA/QC Test	132
11.1	FT Test	132
11.2	QA Test	132
11.3	QC Test	132
12	Part Marking	133
12.1	A523H00X0000	133
12.2	A523M00X0000	134

Figures

Figure 4-1 A523 System Block Diagram	39
Figure 4-2 Medium- and High-End Tablet Solution	40
Figure 6-1 Standard I/O Input Characteristics - CMOS port	84
Figure 6-2 SMHC Voltage Waveform	85
Figure 6-3 Conventional Serial Access Cycle Timing (SAM0)	92
Figure 6-4 EDO Type Serial Access after Read Cycle Timing (SAM1)	92
Figure 6-5 Extending EDO Type Serial Access Mode Timing (SAM2)	93
Figure 6-6 Command Latch Cycle Timing	93
Figure 6-7 Address Latch Cycle Timing	93
Figure 6-8 Write Data to Flash Cycle Timing	94
Figure 6-9 Waiting R/B# Ready Timing	94
Figure 6-10 WE# High to RE# Low Timing	94
Figure 6-11 RE# High to WE# Low Timing	95
Figure 6-12 Address to Data Loading Timing	95
Figure 6-13 SMHC HS-SDR Mode Output Timing Diagram	96
Figure 6-14 SMHC HS-SDR Mode Input Timing Diagram	97
Figure 6-15 SMHC HS-DDR Mode Output Timing Diagram	98
Figure 6-16 SMHC HS-DDR Mode Input Timing Diagram	98
Figure 6-17 SMHC HS200/SDR104 Mode Output Timing Diagram	99
Figure 6-18 SMHC HS200/SDR104 Mode Input Timing Diagram	100
Figure 6-19 SMHC HS400 Mode Output Timing Diagram	101
Figure 6-20 SMHC HS400 Mode Input Timing Diagram	102
Figure 6-21 UART RX Timing	103
Figure 6-22 UART nCTS Timing	103
Figure 6-23 UART nRTS Timing	103
Figure 6-24 SPI Writing Timing	104
Figure 6-25 SPI Reading Timing	104
Figure 6-26 DBI 3-line Serial Interface Timing	105
Figure 6-27 DBI 4-line Serial Interface Timing	106

Figure 6-28 xSPI Target Data Input Timing.....	108
Figure 6-29 xSPI Target Data Output Timing.....	110
Figure 6-30 TWI Timing.....	111
Figure 6-31 RGMII Receive Timing.....	112
Figure 6-32 RGMII Transmit Timing.....	112
Figure 6-33 RMII Receive Timing.....	113
Figure 6-34 RMII Transmit Timing.....	113
Figure 6-35 MIPI DSI Timing.....	114
Figure 6-36 Data Output Timing of I2S/PCM in Master Mode.....	115
Figure 6-37 Data Input Timing of I2S/PCM in Master Mode.....	117
Figure 6-38 OWA Timing.....	119
Figure 6-39 Power-on Timing.....	120
Figure 6-40 Power-off Timing.....	121
Figure 8-1 A523 Pin Map.....	124
Figure 8-2 A523 Package Dimension.....	125
Figure 9-1 A523 Tray Dimension Drawing.....	127
Figure 10-1 Lead-free Reflow Profile.....	130
Figure 10-2 Measuring the Reflow Soldering Process.....	131
Figure 12-1A523H00X0000 Marking.....	133
Figure 12-2 A523M00X0000 Marking.....	134

Tables

Table 2-1 Device Summary	16
Table 5-1 A523 Pin Quantity	41
Table 5-2 SDRAM Pin Characteristics	42
Table 5-3 System Pin Characteristics	45
Table 5-4 RTC&PLL Pin Characteristics	45
Table 5-5 DCXO Pin Characteristics	45
Table 5-6 USB2.0 DRD Pin Characteristics	46
Table 5-7 USB2.0 Host Pin Characteristics	46
Table 5-8 PCIe2.1&USB3.1 DRD Pin Characteristics	46
Table 5-9 eDP1.3 Pin Characteristics	47
Table 5-10 Audio Codec Pin Characteristics	47
Table 5-11 GPADC Pin Characteristics	48
Table 5-12 LRADC Pin Characteristics	49
Table 5-13 Power Pin Characteristics	49
Table 5-14 Port B Pin Characteristics	49
Table 5-15 Port C Pin Characteristics	50
Table 5-16 Port D Pin Characteristics	51
Table 5-17 Port E Pin Characteristics	52
Table 5-18 Port F Pin Characteristics	53
Table 5-19 Port G Pin Characteristics	53
Table 5-20 Port H Pin Characteristics	54
Table 5-21 Port K Pin Characteristics	54
Table 5-22 Port L Pin Characteristics	55
Table 5-23 Port M Pin Characteristics	56
Table 5-24 Ground Pin Characteristics	57
Table 5-25 Port B Multiplex Function	57
Table 5-26 Port C Multiplex Function	57
Table 5-27 Port D Multiplex Function	58
Table 5-28 Port E Multiplex Function	58

Table 5-29 Port F Multiplex Function	59
Table 5-30 Port G Multiplex Function	59
Table 5-31 Port H Multiplex Function	59
Table 5-32 Port K Multiplex Function	60
Table 5-33 Port L Multiplex Function	61
Table 5-34 Port M Multiplex Function	61
Table 5-35 Audio Codec Signal Description	62
Table 5-36 CIR_RX Signal Description	63
Table 5-37 CIR_TX Signal Description	63
Table 5-38 DCXO Signal Description	63
Table 5-39 DMIC Signal Description	64
Table 5-40 eDP1.3 Signal Description	64
Table 5-41 GMAC Signal Description	65
Table 5-42 GPADC Signal Description	65
Table 5-43 I2S/PCM Signal Description	66
Table 5-44 JTAG Signal Description	67
Table 5-45 LEDC Signal Description	67
Table 5-46 LRADC Signal Description	67
Table 5-47 MIPI CSI Signal Description	67
Table 5-48 MIPI DSI Signal Description	68
Table 5-49 RAW NAND Flash Signal Description	69
Table 5-50 OWA Signal Description	70
Table 5-51 Parallel CSI Signal Description	70
Table 5-52 PCIe2.1&USB3.1 DRD Signal Description	70
Table 5-53 PWM Signal Description	71
Table 5-54 RTC&PLL Signal Description	71
Table 5-55 SDRAM Signal Description	71
Table 5-56 SPI&SPI_DBI Signal Description	72
Table 5-57 SPIFC Signal Description	74
Table 5-58 SMHC Signal Description	74
Table 5-59 System Signal Description	75
Table 5-60 TCONLCD Signal Description	75

Table 5-61 TWI Signal Description	76
Table 5-62 USB2.0 DRD Signal Description	77
Table 5-63 USB2.0 Host Signal Description	77
Table 5-64 UART Signal Description	77
Table 6-1 Absolute Maximum Ratings	80
Table 6-2 Recommended Operating Conditions	81
Table 6-3 DC Electrical Characteristics ⁽¹⁾	84
Table 6-4 3.3 V SMHC Electrical Parameters	85
Table 6-5 1.8 V SMHC Electrical Parameters	86
Table 6-6 GPADC Electrical Characteristics	86
Table 6-7 LRADC Electrical Characteristics	86
Table 6-8 Audio Codec Typical Performance Parameters	87
Table 6-9 High-speed 24 MHz Crystal Requirements	89
Table 6-10 Crystal Circuit Parameters	89
Table 6-11 Low-speed 32.768 kHz Crystal Circuit Characteristics	90
Table 6-12 REFCLK-OUT Output Clock Characteristics	91
Table 6-13 X32KFOUT Output Clock Characteristics	91
Table 6-14 Internal Reset Electrical Characteristics	91
Table 6-15 NDFC Timing Constants	95
Table 6-16 SMHC HS-SDR Mode Output Timing Constants	97
Table 6-17 SMHC HS-SDR Mode Input Timing Constants	97
Table 6-18 SMHC HS-DDR Mode Output Timing Constants	98
Table 6-19 SMHC HS-DDR Mode Input Timing Constants	98
Table 6-20 SMHC HS200/SDR104 Mode Output Timing Constants	99
Table 6-21 SMHC HS200 Mode Input Timing Constants	100
Table 6-22 SMHC HS400 Mode Output Timing Constants	101
Table 6-23 SMHC HS400 Mode Input Timing Constants	102
Table 6-24 UART Timing Constants	103
Table 6-25 SPI Timing Constants	104
Table 6-26 DBI 3-line Serial Interface Write Timing Parameters	105
Table 6-27 DBI 3-line Serial Interface Read Timing Parameters	105
Table 6-28 DBI 4-line Serial Interface Write Timing Parameters	106

Table 6-29 DBI 4-line Serial Interface Read Timing Parameters	107
Table 6-30 Clock Input Threshold Levels	108
Table 6-31 xSPI Device Input Timing	108
Table 6-32 xSPI Device Output Timing	110
Table 6-33 TWI Timing Parameters	111
Table 6-34 RGMII Timing Constants	112
Table 6-35 RMII Timing Constants	113
Table 6-36 MIPI DSI Timing Constants	114
Table 6-37 Data Output Timing Parameters of I2S/PCM in Master Mode	115
Table 6-38 Data Input Timing Parameters of I2S/PCM in Master Mode	117
Table 6-39 OWA Timing Constants	119
Table 7-1 Operating and Storage Temperature	122
Table 7-2 Junction Temperature	122
Table 7-3 A523 Package Thermal Characteristics	122
Table 9-1 Matrix Tray Carrier Information	126
Table 9-2 A523 Packing Quantity Information	126
Table 9-3 MSL Summary	127
Table 9-4 Bagged Storage Conditions	128
Table 9-5 Out-of-bag Duration	128
Table 10-1 Lead-free Reflow Profile Conditions	130
Table 12-1 A523H00X0000 Marking Definitions	133
Table 12-2 A523M00X0000 Marking Definitions	134

About This Document

Purpose and Scope

The documentation describes features of each module, pin/signal characteristics, current consumption, interface timing, thermal and package of the A523 series. For details about register descriptions of each module, see the *A523_User_Manual*.

Intended Audience

The document is intended for:

- Design and maintenance personnel for electronics
- Sales personnel for electronic parts and components

Revision Number Definition



This document is released based on the design completion products yet to be mass-produced. Therefore, the information in this document may be modified by reason of mass-produced verification.

All statements, information and recommendations in this document do not constitute any express or implied representation or warranty (including, but not limited to, the warranties of fitness for a particular purpose, merchantability, non-infringement, and accuracy and completeness of the document). Allwinner shall not be liable for any person's use of such information or/and this document.

If you have any questions about the document, please contact us to confirm and obtain the latest version.

Symbol Conventions

The symbols that may be found in this document are defined as follows.

Symbol	Description
 WARNING	A warning means that injury or death is possible if the instructions are not obeyed.
 CAUTION	A caution means that damage to equipment is possible.

Symbol	Description
 NOTE	Provides additional information to emphasize or supplement important points of the main text.

Table Content Conventions

The table content conventions that may be found in this document are defined as follows.

Symbol	Description
-	The cell is blank.

Numerical System

The expressions of the data capacity, the frequency, and the data rate are described as follows.

Type	Symbol	Value
Data capacity	K	1024
	M	1,048,576
	G	1,073,741,824
Frequency, data rate	k	1000
	M	1,000,000
	G	1,000,000,000

1 Overview

A523 series features high-performance platform processors for medium- and high-end tablets and interactive display applications. It integrates octa-core Cortex™-A55 CPU and G57 MC01 GPU to ensure rapid response and smooth running for daily applications, such as on-line video, web browsing, and 3D game. A523 series also supports DDR3/DDR3L/DDR4/LPDDR3/LPDDR4/LPDDR4X, eMMC, NAND, SPI NAND, high-speed interfaces (PCIe2.1 and USB3.1 GEN1), multi video output interfaces (RGB/Dual-LVDS/2xMIPI-DSI/eDP), and video input interfaces (MIPI CSI). In addition, this chip family supports 4K@60fps H.265 decoder, 4K@25fps H.264 encoder, DI, and SmartColor system to provide users with outstanding experience. A523 series can be applied in the tablet PC market and the interactive terminal market.

2 Ordering Information

A523 series contains the following devices:

Table 2-1 Device Summary

Orderable Device	Cortex™-A55 Speed Grade	Maximum Video Decoding Rate		Package
		H.265	VP9	
A523H00X0000	2.0 GHz	4K@60fps, 10 bits	4K@60fps, 10 bits	15 mm x 15 mm , FCCSP 522 balls
A523M00X0000	1.8 GHz	4K@30fps, 8bits	4K@30fps, 8bits	15 mm x 15 mm , FCCSP 522 balls



NOTE

The terms “A523” and “A523 Series” are used in the following document to refer to the all devices listed in Table 2-1.

3 Features

3.1 CPU Architecture

- Octa-core ARM Cortex™-A55 in a DynamIQ big.LITTLE configuration, up to 2.0 GHz
 - 32 KB L1 I-cache and 32 KB L1 D-cache per A55 core
 - Optional 64KB L2 cache per “LITTLE” core
 - Optional 128KB L2 cache per “big” core
- Single-core RISC-V, up to 200 MHz
 - 16 KB I-cache and 16 KB D-cache
 - RV32IMAFIC instructions

3.2 GPU Architecture

- ARM G57 MC01 GPU
- Supports OpenGL ES 3.2/2.0/1.1, Vulkan1.1/1.2/1.3, and OpenCL2.2
- Anti-aliasing algorithm
- High memory bandwidth and low power consumption in 3D graphics processing

3.3 Memory Subsystem

3.3.1 Boot ROM (BROM)

- On-chip memory
- Supports system boot from the following devices:
 - SD Card
 - eMMC
 - RAW NAND Flash
 - SPI NOR Flash (Single Mode and Quad Mode)
 - SPI NAND Flash
- Supports mandatory upgrade process through USB or SD card
- Supports GPADC0 pin and eFuse module to select the boot media type
- Supports normal booting and secure booting
- Secure BROM loads only certified firmware

- Secure BROM ensures that the secure boot is a trusted environment

3.3.2 RAW NAND Flash

- Up to 80-bit ECC per 1024 bytes
- Supports 1K/2K/4K/8K/16K/32K bytes page size
- Up to 8-bit data bus width
- Supports SLC/MLC/TLC flash and EF-NAND
- Supports SDR, ONFI DDR1.0, Toggle DDR1.0, ONFI DDR2.0, and Toggle DDR2.0 RAW NAND FLASH

3.3.3 SDRAM

- 32-bit DDR3/DDR3L/DDR4/LPDDR3/LPDDR4/LPDDR4X interface
- Memory capacity up to 4GB
- 4 chip select lines for for LPDDR3, LPDDR4, and LPDDR4X (especially the 64-bit LPDDR3, LPDDR4, and LPDDR4X)
- Clock frequency up to 1066 MHz for DDR3, DDR3L, and LPDDR3
- Clock frequency up to 1200 MHz for DDR4, LPDDR4, and LPDDR4x

3.3.4 SMHC

- Three SD/MMC host controller (SMHC) interfaces
 - SMHC0, compliant with the protocol Secure Digital Memory (SD3.0)
 - SMHC1, compliant with the protocol Secure Digital I/O (SDIO3.0)
 - SMHC2, compliant with the protocol Multimedia Card (eMMC5.1)
- The SMHC0 and the SMHC1 support the following:
 - 1-bit or 4-bit data width
 - Maximum performance:
 - SDR mode 200 MHz@1.8 V IO pad
 - DDR mode 50 MHz@1.8 V IO pad
 - SDR mode 50 MHz@3.3 V IO pad
- The SMHC2 supports the following:
 - 1-bit, 4-bit, or 8-bit data width
 - Supports HS400 mode and HS200 mode
 - Maximum performance
 - SDR mode 200MHz@1.8V IO pad

- DDR mode 200MHz@1.8V IO pad
- SDR mode 50MHz@3.3V IO pad
- DDR mode 50MHz@3.3V IO pad
- Support block size of 1 to 65535 bytes
- Support hardware CRC generation and error detection

3.4 Video and Graphics

3.4.1 Display Engine (DE)

- Output size up to 4096 x 2048
- Supports seven alpha blending channels for main display and two display outputs
- Supports four overlay layers in each channel, and has an independent scaler
- Supports potter-duff compatible blending operation
- Supports AFBC buffer decoder
- Supports vertical keystone correction
- Input format
 - Semi-planar of YUV422/YUV420/YUV411/P010/P210
 - Planar of YUV422/YUV420/ YUV411
 - ARGB8888/XRGB8888/RGB888/ARGB4444/ ARGB1555/RGB565
- Output format: 8-bit or 10-bit YUV444/YUV422/YUV420/RGB444
- Frame Packing/Top-and-Bottom/Side-by-Side Full/Side-by-Side Half 3D format data
- 10-bit processing path for HDR video
- SmartColor5.0 for excellent display experience
 - Adaptive de-noising for compression noise or mosquito noise with yuv420/422 input
 - Adaptive super resolution scaler
 - Adaptive local dynamic contrast enhancement
 - Adaptive detail/edge enhancement
 - Adaptive color enhancement (blue-stretch, green-stretch, and fresh tone correction) and skin tone protection
 - Hue gain, saturation gain, and value gain controller
 - Fully programmable color matrix
 - Dynamic gamma
- Supports write back for high efficient dual display and miracast

- Supports register configuration queue for register update function

3.4.2 De-interlacer (DI)

- Only off-line processing mode
- Video resolution from 32x32 to 2048x1280 pixel
- Input data format: 8-bit NV12/NV21/YV12 and planar YUV422/planar YUV422 UV-combined
- Output data format
 - 8-bit NV12/NV21/YV12 and planar YUV422/planar YUV422 UV-combined for DIT
 - YV12/planar YUV422 for TNR
- Weave/pixel-motion-adaptive de-interlace method
- Temporal noise reduction
- Film mode detection with video-on-film detection
- Performance
 - Module clock 120MHz for 1080P@60Hz YUV420 with all functions enable
 - Module clock 150MHz for 1080P@60Hz YUV422 with all functions enable

3.4.3 Graphic 2D (G2D)

- Layer size up to 2048x2048 pixels
- Input format and output format contain the following:
 - YUV422 (semi-planar and planar format)
 - YUV420 (semi-planar and planar format)
 - P010, P210, P410, and Y8
 - ARGB8888, XRGB8888, RGB888, ARGB4444, ARGB1555, ARGB2101010, and RGB565
- Multiple rotation types
 - Horizontal flip and vertical flip
 - 0, 90, 180, or 270 degrees' rotation in clockwise direction

3.4.4 Video Engine

3.4.4.1 Video Decoding

- Supports ITU-T H.265 Main/Main10, level 6.1
 - Maximum video resolution:8192x4320
 - Maximum decoding rate: 3840x2160@60fps, 10 bits

- Supports VP9 Profile0/ Profile2, level 6.1
 - Maximum video resolution: 8192 x 4320
 - Maximum decoding rate: 3840x2160@60fps, 10 bits
- Supports ITU-T H.264 Base/Main/High Profile@Level 4.2
 - Maximum video resolution: 3840 x 2160
 - Maximum decoding rate: 3840x2160@30fps, 8 bits

3.4.4.2 Video Encoding

- H.264 BP/MP/HP encoding
 - Supports 4K@25fps@8bits
 - Maximum resolution: 4096 x 4096 (16 megapixels)
 - Supports I/P frame type
 - Supports CBR, VBR and FIXEDQP modes
 - Supports region of interest(ROI) encoding, a maximum of eight ROIs
- JPEG baseline encoding
 - JPEG encoder supports 4K@15fps
 - JPEG encoder supports YUV420, YUV422 and YUV444 format
- MJPEG baseline encoding up to 4K@15fps

3.5 Video Output

3.5.1 eDP1.3

- Up to 2.5K@60fps
- 1-lane, 2-lane, or 4-lane transmission, up to 2.7 Gbit/s per lane
- Video formats: RGB, YCbCr4:4:4, and YCbCr4:2:2
- Color depth: 8-bit and 10-bit per channel
- Supports I2S interface
 - Supports mono sound, stereo sound, and 7.1 surround sound
 - Maximum sampling rate: 192 kHz
- Full link training
- Hot plug detection

- AUX channel
 - Maximum working frequency: 1MHz
 - Adopts Manchester-II encoding
- Clock spread spectrum
- Programmable voltage swing and pre-emphasis
- Embedded ESD

3.5.2 MIPI DSI

- Compliance with MIPI DSI V1.02
- Up to 1.5 Gbit/s for each lane
- Supports 4-lane MIPI DSI, up to 1280 x 720@60fps and 1920 x 1200@60fps
- Supports 4+4-lane MIPI DSI, up to 2560 x 1600@60fps
- Supports non-burst mode with sync pulse/sync event and burst mode
- Pixel format: RGB888, RGB666, RGB666 loosely packed and RGB565
- Supports continuous and non-continuous lane clock modes
- Generic commands support bidirectional communication in LP through data lane 0
- Supports low power data transmission
- Supports ULPS and escape modes
- Supports hardware checksum

3.5.3 TCON LCD

- Two TCON LCD controllers: TONC_LCD0 and TCON_LCD1
- TCON_LCD0 supports the following
 - Supports RGB interface with DE/SYNC mode, up to 1920 x 1080@60fps
 - Supports serial RGB/dummy RGB interface, up to 800 x 480@60fps
 - Supports LVDS interface with dual link, up to 1920 x 1080@60fps
 - Supports LVDS interface with single link, up to 1366 x 768@60fps
 - Dither function for RGB888, RGB666, and RGB565
 - Supports i8080 interface, up to 800 x 480@60fps
 - Supports BT656 interface for NTSC and PAL
 - Supports MIPI DSI interface with dual link, up to 2560x1600@60fps
 - Supports MIPI DSI interface with single link, up to 1920x1200@60fps
- TCON_LCD1 supports MIPI DSI interface with single link, up to 1920x1200@60fps

3.5.4 TCON TV

- One TCON TV controller (TCON_TV1) for eDP1.3
- Up to 2.5K@60Hz
- Output format:
 - 8-bit or 10-bit pixel depth
 - HV

3.6 Video Input

3.6.1 ISP

- Supports one individual image signal processor (ISP), with maximum resolution of 3264x4224 in online mode
- Maximum frame rate of 8M@30fps 2F-WDR
- Supports off-line mode
- Supports WDR spilt, 2F-WDR line-based stitch, dynamic range compression (DRC), tone mapping, digital gain, gamma correction, defect pixel correction (DPC), cross talk correction (CTC), and chromatic aberration correction (CAC)
- Supports 2D/3D noise reduction, bayer interpolation, sharpen, white balance, and color enhancement
- Adjustable 3A functions: automatic white balance (AWB), automatic exposure (AE), and automatic focus (AF)
- Supports anti-flick detection statistics, and histogram statistics

3.6.2 VIPP

- Four VIPP YUV422 or YUV420 outputs
- Maximum resolution of 3264x4224
- Each VIPP has one sub-VIPP in online mode
- Each VIPP has maximum four sub-VIPPs for time division multiplexing in offline mode
- Each Sub-VIPP supports the following:
 - Crop
 - 1 to 1/16 scaling for height and width
 - 16 ORLs
- Supports graphics mirror and flip

3.6.3 MIPI CSI

- 8M@30fps RAW12 2F-WDR, size up to 3264(H) x 2448(V)
- 4+4-lane, 4+2+2-lane, or 2+2+2+2-lane MIPI Interface
 - MIPI CSI2 V1.1
 - MIPI DPHY V1.1
 - 2.0 Gbit/s per lane
- Crop function
- Frame-rate decreasing via software
- 4 DMA controllers for 4 video stream storage
 - Conversion of interlaced input to progressive output (anti-aliasing and noise reduction are not supported)
 - Data conversion supports: YUV422 to YUV420, YUV422 to YUV400, YUV420 to YUV400
 - Horizontal and vertical flip

3.6.4 Parallel CSI

- 16-bit digital camera interface
- Supports 8/10/12/16-bit width
- Supports BT.656, BT.601, BT.1120 interface
- Dual Data Rate (DDR) sample mode with pixel clock up to 148.5MHz
- Supports ITU-R BT.656 up to 4*720P@30fps
- Supports ITU-R BT.1120 up to 4*1080P@30fps

3.7 System Peripherals

3.7.1 Clock Controller Unit (CCU)

- 10 PLLs
- One on-chip RC oscillator
- Supports one external 24 MHz DCXO and one external 32.768 kHz oscillator
- Supports clock configuration and clock generation for corresponding modules
- Supports software-controlled clock gating and software-controlled reset for corresponding modules

3.7.2 DMAC

- Two 16-ch DMAs

- Provides 53 peripheral DMA requests for data reading and 53 peripheral DMA requests for data writing
- Transferring data with linked list
- Flexible data width: 8 bits, 16 bits, or 32 bits
- Programmable DMA burst length
- DRQ response includes waiting mode and handshake mode
- Supports non-aligned transform for memory devices
- DMA channels that support the following:
 - Pausing DMA
 - BMODE and I/O speed mode
 - DMA timeout

3.7.3 I/O Memory Management Unit (IOMMU)

- Supports virtual address to physical address mapping by hardware implementation
- Supports ISP, CSI, VE_MBUS0, VE_MBUS1, G2D, DE, and DI parallel address mapping
- Supports ISP, CSI, VE_MBUS0, VE_MBUS1, G2D, DE, and DI bypass function independently
- Supports ISP, CSI, VE_MBUS0, VE_MBUS1, G2D, DE, and DI pre-fetch independently
- Supports ISP, CSI, VE_MBUS0, VE_MBUS1, G2D, DE, and DI interrupt handling mechanism independently
- Supports 2 levels TLB (level1 TLB for special using, and level2 TLB for sharing)
- Supports TLB Fully cleared and Partially disabled
- Supports trigger PTW behavior when TLB miss
- Supports checking the permission

3.7.4 Message Box (MSGBOX)

- Supports communication between two CPUs through one way channels. Each CPU has one MSGBOX and can only read or write in one communication
 - CPUX_MSGBOX: CPUS/RISC-V write; ARM CPU read
 - CPUS_MSGBOX: ARM CPU/RISC-V write; CPUS read
 - RISCV_MSGBOX: ARM CPU/CPUS write; RISC-V read
- The channel between two CPU has 4 channels, and the FIFO depth of a channel is 8 x 32 bits
- Supports interrupts

3.7.5 Power Reset Clock Management (PRCM)

- Two PRCMs: PRCM and MCU_PRCM
- 1 PLL
- CPUS Clock Configuration
- APBS Clock Configuration
- CPUS Module Clock Configuration
- CPUS Module BUS Gating and Reset
- RAM configure Control for PRCM

3.7.6 RTC

- Provides a 16-bit counter for counting day, 5-bit counter for counting hour, 6-bit counter for counting minute, 6-bit counter for counting second
- External connect a 32.768 kHz low-frequency oscillator for count clock
- Timer frequency is 1 kHz
- Configurable initial value by software anytime
- Supports fanout function of internal 32K clock
- Supports timing alarm, and generates interrupt and wakeup the external devices
- 8 general purpose registers for storing power-off information in AON domain

3.7.7 Spinlock

- Supports 32 lock units
- Two kinds of lock status: locked and unlocked
- Lock time of the processor is predictable (less than 200 cycles)

3.7.8 Thermal Sensor Controller (THS)

- Two THS controllers
 - THS0, including TSENSOR4
 - THS1, including TSENSOR0, TSENSOR1, and TSENSOR2
- Temperature accuracy: $\pm 5^{\circ}\text{C}$ from -40°C to 60°C , $\pm 3^{\circ}\text{C}$ from -60°C to $+125^{\circ}\text{C}$
- Averaging filter for thermal sensor reading
- Supports over-temperature protection interrupt and over-temperature alarm interrupt

3.7.9 Timer

- Configurable counting clock: 32KHz, 24MHz, 16MHz, or 200MHz

- Programmable 56-bit down timer
- Two working modes: periodic mode and single count mode
- Generates an interrupt when the count is decreased to 0

3.7.10 Watchdog Timer (WDT)

- Supports 12 initial values
- Supports the generation of timeout interrupts
- Supports the generation of reset signals
- Supports Watchdog Restart

3.8 Audio Subsystem

3.8.1 Audio Codec

- Two audio digital-to-analog converter (DAC) channels
 - 16-bit and 20-bit sample resolution
 - 8 kHz to 192 kHz DAC sample rate
 - 100 ± 2 dB SNR@A-weight, -85 ± 3 dB THD+N
- Three audio outputs
 - One stereo headphone output: HPOUTL/R
 - Two differential lineout outputs: LINEOUTLP/N and LINEOUTRP/N
- Three audio analog-to-digital converter (ADC) channels
 - 16-bit and 20-bit sample resolution
 - 8 kHz to 48 kHz ADC sample rate
 - 95 ± 3 dB SNR@A-weight, -80 ± 3 dB THD+N
- Three differential microphone inputs: MICIN1P/1N, MICIN2P/2N, and MICIN3P/3N (for echo reduction)
- Two low-noise analog microphone bias outputs: MBIAS and HBIAS
- Supports Dynamic Range Controller adjusting the DAC playback and ADC recording
- One 128x20-bits FIFO for DAC data transmit, one 128x20-bits FIFO for ADC data receive
- Programmable FIFO thresholds
- Supports interrupts and DMA
- Internal ALDO output for AVCC

3.8.2 I2S/PCM

- Four I2S/PCM external interfaces (I2S0, I2S1, I2S2, and I2S3) for connecting external power amplifier and MIC ADC
- Compliant with standard Philips Inter-IC sound (I2S) bus specification
 - Left-justified, Right-justified, PCM mode, and TDM format
 - Programmable PCM frame width: 1 BCLK width (short frame) and 2 BCLKs width (long frame)
- FIFOs for transmitting and receiving data
 - Programmable FIFO thresholds
 - 128 depth x 32-bit width TXFIFO and 64 depth x 32-bit width RXFIFO
- Supports multiple function clocks
 - Clock up to 24.576 MHz Data Output of I2S/PCM in Master mode (Only if the IO PAD and Peripheral I2S/PCM satisfy Timing Parameters)
 - Clock up to 12.288 MHz Data Input of I2S/PCM in Master mode
- Supports TX/RX DMA slave interface
- Supports multiple application scenarios
 - Up to 16 channels ($f_s = 48$ kHz) which has adjustable width from 8-bit to 32-bit
 - Sample rate from 8 kHz to 384 kHz ($\text{sample rate} * \text{channel} * \text{slot width} \leq 24.576$ MHz)
 - 8-bit u-law and 8-bit A-law companded sample
- Supports master/slave mode

3.8.3 DMIC

- Supports maximum 8 digital PDM microphones
- Supports sample rate from 8 kHz to 48 kHz

3.8.4 One Wire Audio (OWA)

- One OWA TX and One OWA RX
- Compliance with S/PDIF interface
- IEC-60958 and IEC-61937 transmitter and receiver functionality
- IEC-60958 supports data formats: 16 bits, 20 bits, and 24 bits
- TXFIFO and RXFIFO
 - One 128×24 bits TXFIFO and one 64×24 bits RXFIFO for audio data transfer
 - Programmable FIFO thresholds

- Supports TX/RX DMA slave interface
- Multiple function clock
 - Separate clock for OWA TX and OWA RX
 - The clock of TX function includes 24.576 MHz and 22.5792 MHz
 - The clock of RX function includes 24.576*8 MHz
- Supports Hardware Parity On TX/RX
 - Hardware Parity generation on the transmitter
 - Hardware Parity checking on the receiver
- Supports channel status capture on the receiver
- Supports channel sample rate capture on the receiver
- Supports insertion detection for the receiver
- Supports channel status insertion for the transmitter

3.9 Security System

3.9.1 Crypto Engine (CE)

- Symmetrical algorithm:
 - AES symmetrical algorithm
 - Key size: 128/192/256 bits
 - CFB mode includes: CFB1, CFB8, CFB64, and CFB128
 - CTR mode includes: CTR16, CTR32, CTR64, and CTR128
 - Supports ECB, CBC, CTS, OFB, CBC-MAC, and GCM modes
 - DES symmetrical algorithm
 - CTR mode, includes: CTR16, CTR32, and CTR64
 - Supports ECB, CBC, and CBC-MAC mode
 - Supports 3DES
 - SM4 symmetrical algorithm supports ECB and CBC mode
- Hash algorithms
 - Support MD5, SHA1, SHA224, SHA256, SHA384, SHA512, and SM3
 - Support HMAC-SHA1, HMAC-SHA256
- Random bit generator algorithms
 - Support PRNG, 175 bits seed width, and output with multiple of 5 words

- Support TRNG, post-process by hardware with SHA256, output with multiple of 8 words
- Public key algorithms
 - Support RSA public key algorithms: 512/1024/2048/3072/4096-bit width
 - Support ECC public key algorithms: 160/224/256/384/521-bit width
 - Support SM2 algorithms

3.9.2 Security ID (SID)

- 4 Kbits eFuse
- Supports secure and non-secure world in eFuse
- The register configuration of SID is always in non-secure world
- Backup eFuse information by using SID_SRAM
- One-time programming
- Selecting double-bit check by parameter definition
- Data scrambling
- Reading and writing protection

3.9.3 Secure Memory Control (SMC)

- The SMC is always secure, only secure CPUX can access the SMC
- Sets secure area of DRAM
- Supports Master and address protection
- Sets secure property that Master accesses to DRAM
- Sets DRM area
- Maximum 16 regions and Master has access to each region

3.9.4 Secure Peripherals Control (SPC)

- The SPC is always secure, only secure CPU can access the SPC
- Sets secure property of peripherals

3.10 External Peripherals

3.10.1 CIR Receiver (CIR_RX)

- Two CIR_RX interfaces
- Full physical layer implementation
- Supports NEC format infra data

- Supports CIR for remote control
- 64x8 bits FIFO for data buffer
- Sample clock up to 1 MHz

3.10.2 CIR Transmitter (CIR_TX)

- One CIR_TX interface
- Full physical layer implementation
- Arbitrary wave generator
- Configurable carrier frequency
- Handshake mode and waiting mode of DMA
- 128 bytes FIFO for data buffer
- Supports Interrupts and DMA

3.10.3 GAMC

- One GMAC interface (GMAC) for connecting external Ethernet PHY
- 10/100/1000 Mbit/s Ethernet port with RGMII and RMII interfaces
- Compliant with IEEE 802.3-2002 standard
- Supports both full-duplex and half-duplex operations
- Programmable frame length to support Standard or Jumbo Ethernet frames with sizes up to 16 KB
- Supports a variety of flexible address filtering modes
- Separate 32-bit status returned for transmission and reception packets
- Optimization for packet-oriented DMA transfers with frame delimiters
 - Supports linked-list descriptor list structure
 - Descriptor architecture, allowing large blocks of data transfer with minimum CPU intervention; each descriptor can transfer up to 4 KB of data
 - Comprehensive status reporting for normal operation and transfers with errors
- 2 KB TXFIFO for transmission packets and 8 KB RXFIFO for reception packets
- Programmable interrupt options for different operational conditions
- Provides the management data input/output (MDIO) interface for PHY device configuration and management with configurable clock frequencies

3.10.4 General Purpose ADC (GPADC)

- 4-ch successive approximation register (SAR) analog-to-digital converter (ADC)

- 64 FIFO depth of data register
- 12-bit sampling resolution and 10-bit precision
- Power reference voltage: AVCC, analog input voltage range: 0 to AVCC
- Maximum sampling frequency up to 1 MHz
- Supports three operation modes: single conversion mode, continuous conversion mode, burst conversion mode

3.10.5 LEDC

- Configurable LED output high/low level width
- Configurable LED reset time
- LEDC data supports DMA configuration mode and CPU configuration mode
- Maximum 1024 LEDs serial connect
- Configurable interval time between data packets and frame data
- Configurable RGB display mode

3.10.6 Low Rate ADC (LRADC)

- 2-ch LRADC input
- 6-bit resolution
- Sampling rate up to 2 KHz
- Supports hold key and general key
- Supports normal, continue and single work mode
- Power supply voltage:1.8V, power reference voltage:1.35V

3.10.7 USB2.0 DRD

- One USB2.0 DRD (USB0), with integrated USB 2.0 analog PHY
- Complies with USB2.0 Specification
- Supports static host operation:
 - Compatible with Enhanced Host Controller Interface (EHCI) Specification, Version 1.0
 - Compatible with Open Host Controller Interface (OHCI) Specification, Version 1.0a
 - Supports High-Speed (HS, 480 Mbit/s), Full-Speed (FS, 12 Mbit/s), and Low-Speed (LS, 1.5 Mbit/s)
 - Supports only 1 USB Root port shared between EHCI and OHCI
- Supports static host operation:
 - Supports High-Speed (HS, 480 Mbit/s), Full-Speed (FS, 12 Mbit/s)

- Supports bi-directional endpoint0 (EP0) for Control transfer
- Up to 10 user-configurable endpoints (EP1 IN/OUT, EP2 IN/OUT, EP3 IN/OUT, EP4 IN/OUT, EP5 IN/OUT) for Bulk transfer, Isochronous transfer and Interrupt transfer
- Up to (8 KB + 64 Bytes) FIFO for all EPs (including EP0)
- Supports interface to an external Normal DMA controller for every EP
- Supports an internal DMA controller for data transfer with memory
- Supports High-Bandwidth Isochronous & Interrupt transfers
- Automated splitting/combining of packets for Bulk transfers
- Includes automatic PING capabilities
- Soft connect/disconnect function
- Hardware handles all data transfer
- Power optimization and power management capabilities
- Device and host controller share an 8K SRAM and a physical PHY

3.10.8 USB2.0 HOST

- One USB 2.0 HOST (USB1), with integrated USB 2.0 analog PHY
- Supports High-Speed (HS, 480 Mbit/s), Full-Speed (FS, 12 Mbit/s) and Low-Speed (LS, 1.5 Mbit/s) Device
- Compatible with Enhanced Host Controller Interface (EHCI) Specification, Version 1.0
- Compatible with Open Host Controller Interface (OHCI) Specification, Version 1.0a
- Supports only 1 USB Root port shared between EHCI and OHCI
- An internal DMA Controller for data transfer with memory
- Supports the UTMI+ Level 3 interface and 8-bit bidirectional data buses
- Industry-standard AMBA High-Performance Bus (AHB), fully compliant with the AMBA Specification, Revision 2.0.
- 32-bit Little Endian AMBA AHB Slave Bus for Register Access
- 32-bit Little Endian AMBA AHB Master Bus for Memory Access

3.10.9 PCIe2.1&USB3.1 System

PCIe2.1&USB3.1 system contains 1 PCIe2.1&USB3.1 combo PHY, 1 PCIe2.1 controller and 1 USB3.1 GEN1 DRD controller.

3.10.9.1 PCIe2.1

- Compliance to PCI Express Base Specification, Revision 2.1

- Supports Gen1(2.5 Gbit/s), Gen2 (5.0 Gbit/s) speed
- Supports 62.5MHz/125 MHz operation on PIPE interface for Gen1/Gen2, respectively
- Constant 32-bit PIPE width for Gen1/Gen2 modes
- Supports Root Complex (RC) mode
- Supports 1 lane link width
- Eight Traffic Classes (TC)
- Maximum payload size of 1K bytes
- 8 inbound and 8 outbound address translation regions
- 4 write/read channels for embedded DMA
- Maximum number of non-posted outstanding transactions: 32
- Supports Active State Power Management (ASPM)
- Supports Advanced Error Reporting (AER)
- Supports MSI interrupt

3.10.9.2 USB3.1 DRD



NOTE

USB2.0 PHY and USB3.1 PHY share the same controller. They cannot be used simultaneously.

- Compliant with USB3.1 GEN1 Specification
- One USB 2.0 UTMI+ PHY (USB2)
- One USB3.1 PIPE PHY (USB3)
- USB3.1 DRD Device mode supports the following:
 - Super-Speed (SS, 5 Gbit/s) for USB3.1 PHY
 - High-Speed (HS, 480 Mbit/s) and Full-Speed (FS, 12-Mbit/s) for USB2.0 PHY
- USB3.1 DRD HOST mode supports the following:
 - Super-Speed (SS, 5 Gbit/s) for USB3.1 PHY
 - High-Speed (HS, 480 Mbit/s), Full-Speed (FS, 12 Mbit/s) and Low-Speed (LS, 1.5 Mbit/s) for USB2.0 PHY
- Supports Device or Host operation at a time
- AXI interface for DMA operation
- Reading and writing access to Control and Status Registers (CSRs) through AHB Slave interface

- Up to 10 endpoints, including bi-directional control endpoint 0 in Device mode:
 - 5 IN Endpoints: User EP1 IN, EP2 IN, EP3 IN, EP4 IN, Control EP0
 - 5 OUT Endpoints: User EP1 OUT, EP2 OUT, EP3 OUT, EP4 OUT, Control EP0
- Simultaneous IN and OUT transfer in Super-Speed mode
- Dual-port interfaces for TX data buffering, RX data prefetching, descriptor caching, and register caching
- Three RAMs: Rx data FIFO RAM, TX data FIFO RAM, and descriptor/register Cache RAM
- Hardware handles all data transfer
- Implements both static and dynamic power reduction techniques at multiple levels

3.10.10 PWM

- Up to Up to 20 PWM channels and 10 S-PWM channels
- Maximum 16 independent PWM channels for PWM controller
 - Supports PWM continuous mode output
 - Supports PWM pulse mode output, and the pulse number is configurable
 - Output frequency range:
 - 0 to 24 MHz (when the clock source is DCXO24M)
 - 0 to 100 MHz (when the clock source is APB1 clock)
 - Various duty-cycle: 0% to 100%
 - Minimum resolution: 1/65536
- Maximum 8 complementary pairs output for PWM controller
 - The pairing methods are as follows. The components are PWM output signals.
 - PWM Channels
 PWM0 + PWM1, PWM2 + PWM3, PWM4 + PWM5, PWM6 + PWM7, PWM8 + PWM9,
 PWM10 + PWM11, PWM12 + PWM13, PWM14 + PWM15, PWM16+PWM17,
 PWM18+PWM19
 - S-PWM Channels
 S-PWM0+S-PWM1, S-PWM2+S-PWM3, S-PWM4+S-PWM5, S-PWM6+S-PWM7,
 S-PWM8+S-PWM9
 - Supports dead-zone generator, and the dead-zone time is configurable
- Maximum 4 group of PWM channel output for controlling stepping motors
 - Supports any plural channels to form a group, and output the same duty-cycle pulse

- In group mode, the relative phase of the output waveform for each channel is configurable
- Maximum 16 channels capture input
 - Supports rising edge detection and falling edge detection for input waveform pulse
 - Supports pulse-width measurement for input waveform pulse

3.10.11 SPI and SPI_DBI

- Up to 4 SPI controllers
 - SPI0, SPI1, and SPI2 in CPUX Domain
 - S-SPI0 in CPUS Domain
- The SPI0, SPI2, and S-SPI0 support SPI mode; The SPI1 supports SPI mode and display bus interface (DBI) mode

SPI mode

- Multiple SPI modes:
 - Master mode and slave mode for standard SPI
 - Master mode for Dual-Output/Dual-Input SPI and Dual I/O SPI
 - Master mode for Quad-Output/Quad-Input SPI
 - Master mode for 3-wire SPI, with programmable serial data frame length of 1 bit to 32 bits
- Maximum clock frequency: 100MHz
- TX/RX DMA slave interface
- 8-bit wide by 64-entry FIFO for both transmitting and receiving data
- Supports mode0, mode1, mode2, and mode3
- Polarity and phase of the Chip Select (SPI_SS) and SPI Clock (SPI_SCLK) are configurable

DBI mode

- DBI Type C 3 Line/4 Line Interface Mode
- 2 Data Lane Interface Mode
- RGB111/444/565/666/888 video format
- Maximum resolution of RGB666 240 x 320@30Hz with single data lane
- Maximum resolution of RGB888 240 x 320@60Hz or 320 x 480@30Hz with dual data lane
- Tearing effect
- Software flexible control video frame rate

3.10.12 SPI Flash Controller (SPIFC)

- Supports multiple SPI modes
 - Standard SPI
 - Dual-Input/Dual-Output SPI and Dual-I/O SPI
 - Quad-Input/Quad-Output SPI, Quad-I/O SPI, and QPI
 - Octal-Input/Octal-Output SPI, Octal-I/O SPI, and OPI
 - 3-wire SPI with programmable serial data frame length of 1 bit to 32 bits
- Supports STR mode and DTR mode, and DTR mode supports DQS signal
- High Speed Clock Frequency
 - 150MHz for STR Mode
 - 100MHz for DTR Mode
- Software Write Protection
 - Write protection for all/portion of memory via software
 - Top/Bottom Block protection
- Programmable delay between transactions
- Supports Mode0, Mode1, Mode2 and Mode3
- Supports control signal configuration
 - Up to four chip selects to support multiple peripherals
 - Polarity and phase of the Chip Select (SPI_SS) and SPI Clock (SPI_SCLK) are configurable

3.10.13 Two Wire Interface (TWI)

- Up to 9 TWI controllers
 - TWI0, TWI1, TWI2, TWI3, TWI4, and TWI5
 - S_TWI0, S_TWI1, and S_TWI2
- Compliant with I2C bus standard
- 7-bit and 10-bit device addressing modes
- Standard mode (up to 100 Kbit/s) and fast mode (up to 400 Kbit/s)
- Supports general call and start byte
- Master mode supports the following:
 - Bus arbitration in the case of multiple master devices
 - Clock synchronization and bit and byte waiting

- Packet transmission and DMA
- Slave mode supports Interrupt on address detection

3.10.14 UART

- Up to 10 UART controllers
 - UART0, UART1, UART2, UART3, UART4, UART5, UART6, and UART7
 - S_UART0 and S_UART1
- Compatible with industry-standard 16450/16550 UARTs
- Two separate FIFOs: one is RX FIFO, and the other is TX FIFO
 - Each of them is 64 bytes for UART0, S_UART0, and S_UART1
 - Each of them is 128 bytes for UART1, UART2, UART3, UART4, UART5, UART6, and UART7
- The working reference clock is from the APB bus clock
 - Speed up to 10 Mbit/s with 160 MHz APB clock (excluding S_UART0 and S_UART1)
 - Speed up to 5 Mbit/s with 80 MHz APB clock (excluding S_UART0 and S_UART1)
 - Speed up to 3.75 Mbit/s with 60 MHz APB clock (excluding S_UART0 and S_UART1)
 - Speed up to 1.5 Mbit/s with 24 MHz APB clock
- 5 to 8 data bits for RS-232 format, or 9 bits RS-485 format
- 1, 1.5 or 2 stop bits
- Programmable parity (even, odd, or no parity)
- Supports TX/RX DMA slave controller interface
- Supports software/hardware flow control
- Supports IrDA-compatible slow infrared (SIR) format
- Supports auto-flow by using CTS & RTS (excluding UART0, S_UART0, and S_UART1)

3.11 Package

FCCSP 522 balls, 15 mm x 15 mm body size, 0.5 mm ball pitch, 0.3 mm ball size

4 Block Diagram

The following figure shows the system block diagram of the A523.

Figure 4-1 A523 System Block Diagram

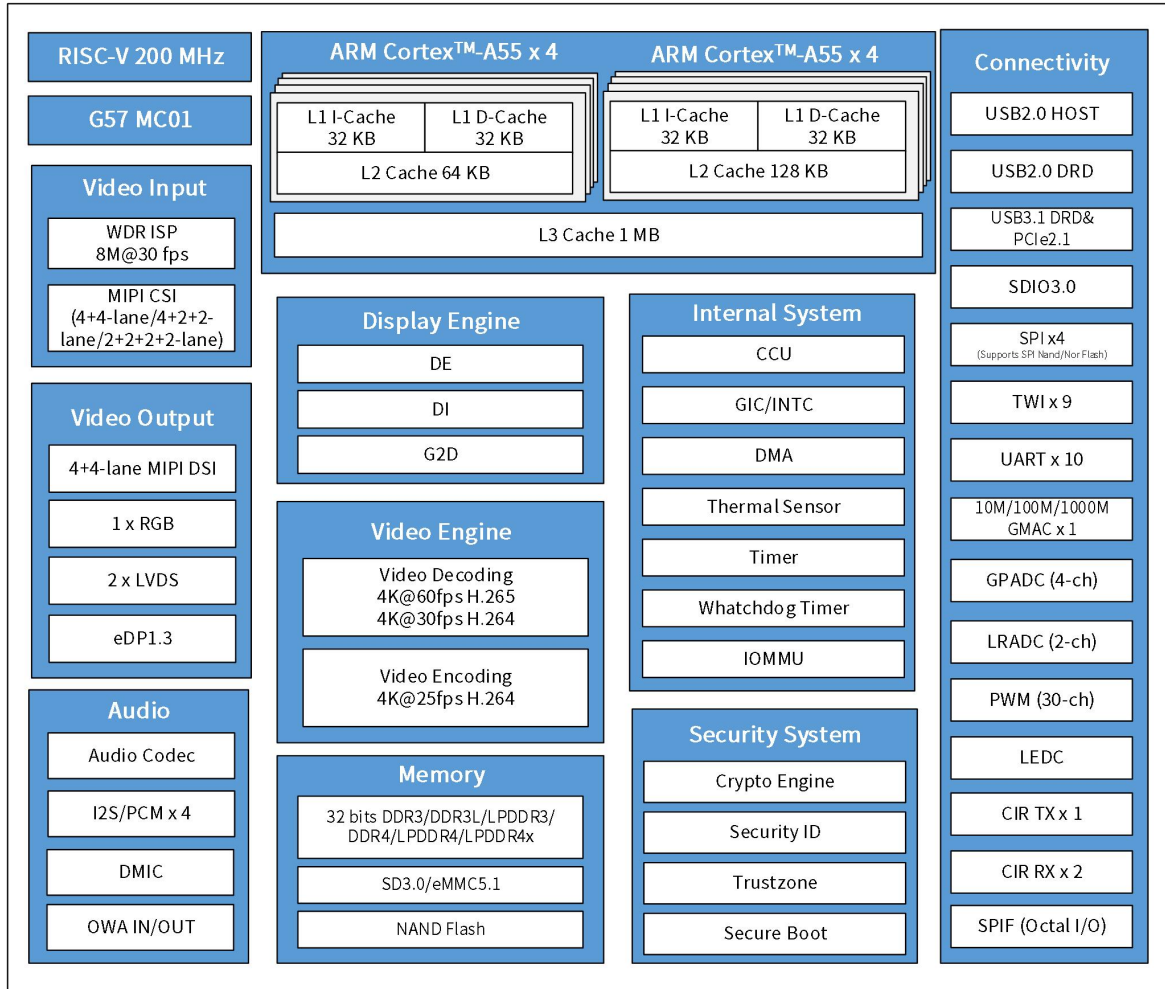

The following figure shows the medium- and high-end tablet solution of the A523

Figure 4-2 Medium- and High-End Tablet Solution

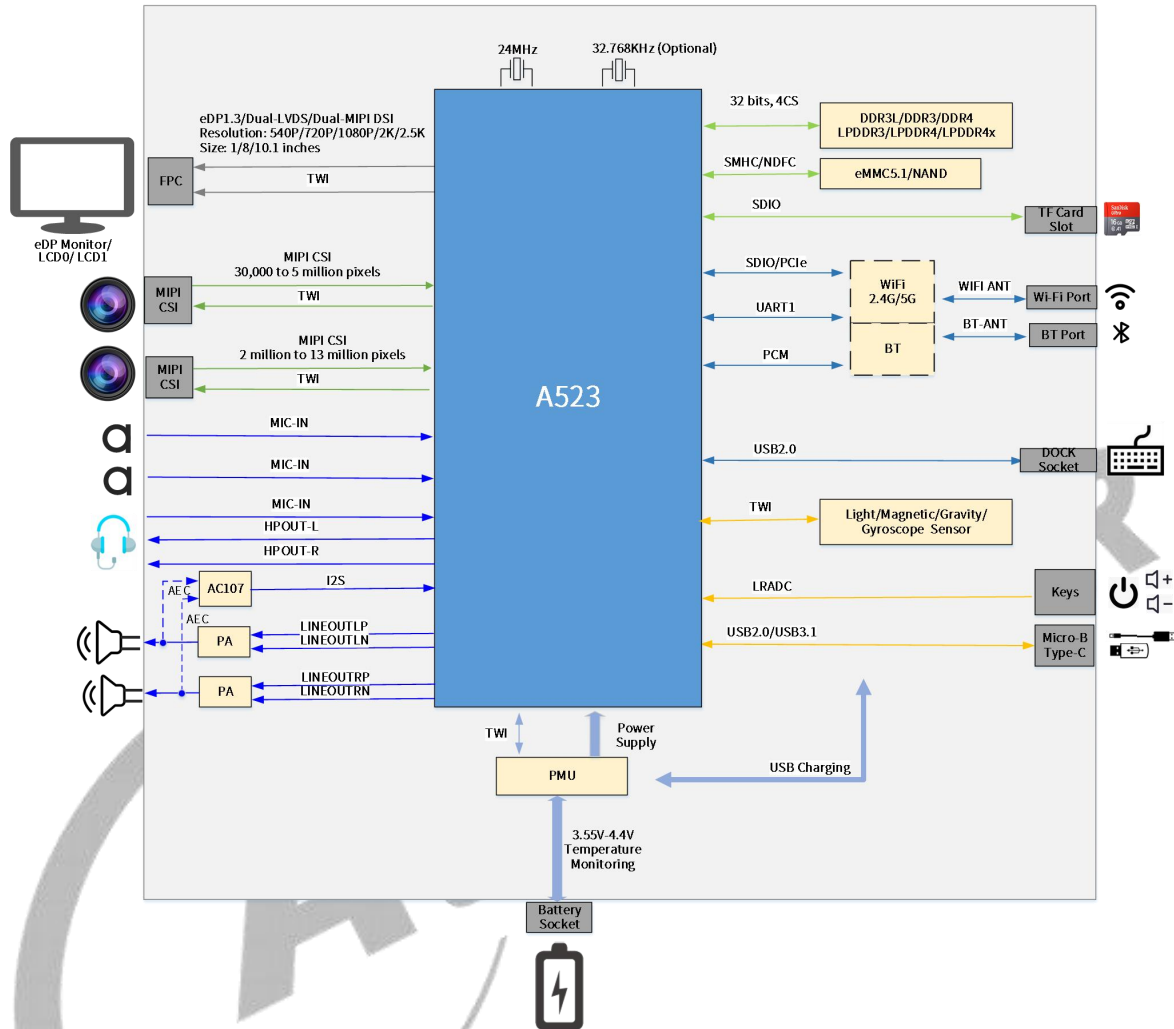

5 Pin Description

5.1 Pin Quantity

The following table lists the pin quantity of the A523.

Table 5-1 A523 Pin Quantity

Pin Type	Quantity
I/O	304
Power	63
DDR power	13
Ground	142
Total	522

5.2 Pin Characteristics

The following tables list the characteristics of the A523 pins from the following seven aspects.

[1] **Ball#:** Package ball numbers associated with each signal.

[2] **Pin Name:** The name of the package pin.

NC means these pins are not connected.

[3] **Type:** Denotes the signal direction

I (Input),

O (Output),

I/O (Input/Output),

OD (Open-Drain),

A (Analog),

AI (Analog Input),

AO (Analog Output),

P (Power),

G (Ground),

N/A (Not Applicable).

[4] Ball Reset State: The state of the terminal at reset.

PU: pull up

PD: pull down

Z: high impedance

N/A: Not Applicable

[5] Pull Up/Down: Denotes the presence of an internal pull-up or pull-down resistor. Pull-up and pull-down resistors can be enabled or disabled via software.

PU: Internal pullup

PD: Internal pulldown

PU/PD: Internal pullup and pulldown

N/A: Not Applicable

[6] Default Buffer Strength: Defines the default drive strength of the associated output buffer. The maximum drive strength of each GPIO is 6 mA.

N/A means Not Applicable.

[7] I/O Power Supply: The voltage supplies for the IO buffers of the terminal.

N/A means Not Applicable.

5.2.1 SDRAM

Table 5-2 SDRAM Pin Characteristics

Ball# ^[1]	Pin Name ^[2]	Type ^[3]	I/O Power Supply ^[4]
AF29	SA0	O	VCC-DRAM/VCC-DRAML
AC26	SA1	O	VCC-DRAM/VCC-DRAML
AE29	SA2	O	VCC-DRAM/VCC-DRAML
AG23	SA3	O	VCC-DRAM/VCC-DRAML
AD21	SA4	O	VCC-DRAM/VCC-DRAML
AF23	SA5	O	VCC-DRAM/VCC-DRAML
AJ23	SA6	O	VCC-DRAM/VCC-DRAML
AH29	SA7	O	VCC-DRAM/VCC-DRAML
AG21	SA8	O	VCC-DRAM/VCC-DRAML
AE27	SA9	O	VCC-DRAM/VCC-DRAML
AC25	SA10	O	VCC-DRAM/VCC-DRAML
AE28	SA11	O	VCC-DRAM/VCC-DRAML

Ball# ^[1]	Pin Name ^[2]	Type ^[3]	I/O Power Supply ^[4]
AG27	SA12	O	VCC-DRAM/VCC-DRAML
AF25	SA13	O	VCC-DRAM/VCC-DRAML
AH24	SA14	O	VCC-DRAM/VCC-DRAML
AJ25	SA15	O	VCC-DRAM/VCC-DRAML
AE23	SA16	O	VCC-DRAM/VCC-DRAML
AE26	SA17	O	VCC-DRAM/VCC-DRAML
AG25	SACT	O	VCC-DRAM/VCC-DRAML
AF21	SBA0	O	VCC-DRAM/VCC-DRAML
AE21	SBA1	O	VCC-DRAM/VCC-DRAML
AJ22	SBG0	O	VCC-DRAM/VCC-DRAML
AH23	SBG1	O	VCC-DRAM/VCC-DRAML
AH27	SCKE0	O	VCC-DRAM/VCC-DRAML
AH26	SCKP	O	VCC-DRAM/VCC-DRAML
AJ26	SCKN	O	VCC-DRAM/VCC-DRAML
AJ28	SCS0	O	VCC-DRAM/VCC-DRAML
AH28	SCS1	O	VCC-DRAM/VCC-DRAML
AA24	SDQ0	I/O	VCC-DRAM/VCC-DRAML
AA23	SDQ1	I/O	VCC-DRAM/VCC-DRAML
AC28	SDQ2	I/O	VCC-DRAM/VCC-DRAML
AD29	SDQ3	I/O	VCC-DRAM/VCC-DRAML
AA26	SDQ4	I/O	VCC-DRAM/VCC-DRAML
Y28	SDQ5	I/O	VCC-DRAM/VCC-DRAML
AA27	SDQ6	I/O	VCC-DRAM/VCC-DRAML
Y29	SDQ7	I/O	VCC-DRAM/VCC-DRAML
W23	SDQ8	I/O	VCC-DRAM/VCC-DRAML
W24	SDQ9	I/O	VCC-DRAM/VCC-DRAML
W26	SDQ10	I/O	VCC-DRAM/VCC-DRAML
W27	SDQ11	I/O	VCC-DRAM/VCC-DRAML
U29	SDQ12	I/O	VCC-DRAM/VCC-DRAML
U27	SDQ13	I/O	VCC-DRAM/VCC-DRAML
U24	SDQ14	I/O	VCC-DRAM/VCC-DRAML
U23	SDQ15	I/O	VCC-DRAM/VCC-DRAML
AH21	SDQ16	I/O	VCC-DRAM/VCC-DRAML

Ball# ^[1]	Pin Name ^[2]	Type ^[3]	I/O Power Supply ^[4]
AJ21	SDQ17	I/O	VCC-DRAM/VCC-DRAML
AD19	SDQ18	I/O	VCC-DRAM/VCC-DRAML
AF19	SDQ19	I/O	VCC-DRAM/VCC-DRAML
AG19	SDQ20	I/O	VCC-DRAM/VCC-DRAML
AH18	SDQ21	I/O	VCC-DRAM/VCC-DRAML
AJ17	SDQ22	I/O	VCC-DRAM/VCC-DRAML
AC17	SDQ23	I/O	VCC-DRAM/VCC-DRAML
AC15	SDQ24	I/O	VCC-DRAM/VCC-DRAML
AD15	SDQ25	I/O	VCC-DRAM/VCC-DRAML
AF15	SDQ26	I/O	VCC-DRAM/VCC-DRAML
AG15	SDQ27	I/O	VCC-DRAM/VCC-DRAML
AH17	SDQ28	I/O	VCC-DRAM/VCC-DRAML
AG17	SDQ29	I/O	VCC-DRAM/VCC-DRAML
AF17	SDQ30	I/O	VCC-DRAM/VCC-DRAML
AD17	SDQ31	I/O	VCC-DRAM/VCC-DRAML
AA29	SDQM0	I/O	VCC-DRAM/VCC-DRAML
W28	SDQM1	I/O	VCC-DRAM/VCC-DRAML
AH20	SDQM2	I/O	VCC-DRAM/VCC-DRAML
AJ16	SDQM3	I/O	VCC-DRAM/VCC-DRAML
AB28	SDQS0P	I/O	VCC-DRAM/VCC-DRAML
AB29	SDQS0N	I/O	VCC-DRAM/VCC-DRAML
V28	SDQS1P	I/O	VCC-DRAM/VCC-DRAML
V29	SDQS1N	I/O	VCC-DRAM/VCC-DRAML
AH19	SDQS2P	I/O	VCC-DRAM/VCC-DRAML
AJ19	SDQS2N	I/O	VCC-DRAM/VCC-DRAML
AH15	SDQS3P	I/O	VCC-DRAM/VCC-DRAML
AJ15	SDQS3N	I/O	VCC-DRAM/VCC-DRAML
AG28	SODT0	O	VCC-DRAM/VCC-DRAML
AG29	SODT1	O	VCC-DRAM/VCC-DRAML
AC19	SRST	O	VCC-DRAM/VCC-DRAML
U25	SZQ	AI	VCC-DRAM/VCC-DRAML
T20, T21, T22, U21, V21, W21, Y21	VCC-DRAM	P	N/A

Ball# ^[1]	Pin Name ^[2]	Type ^[3]	I/O Power Supply ^[4]
Y14, Y15, Y16, Y17, Y19	VCC-DRAML	P	N/A
AA21	VDD18-DRAM	P	N/A

5.2.2 System

Table 5-3 System Pin Characteristics

Ball# ^[1]	Pin Name ^[2]	Type ^[3]	Ball Reset State ^[4]	Pull Up/Down ^[5]	I/O Power Supply ^[6]
E12	FEL	I	PU	PU	VCC-IO
F12	JTAG-SEL	I	PU	PU	VCC-IO
AE1	TEST	I	PD	PD	VCC-RTC
AD11	NMI	I/O, OD	N/A	N/A	VCC-RTC
AC11	RESET	I/O, OD	N/A	N/A	VCC-RTC

5.2.3 RTC&PLL

Table 5-4 RTC&PLL Pin Characteristics

Ball# ^[1]	Pin Name ^[2]	Type ^[3]	I/O Power Supply ^[4]
AG11	X32KFOUT	AO, OD	VCC-PM
AH12	X32KIN	AI	VCC-RTC
AH11	X32KOUT	AO	VCC-RTC
AD13	PLLTEST	AO, OD	VCC-PLL
AA10	VCC-RTC	P	N/A
AB13	VCC-PLL	P	N/A

5.2.4 DCXO

Table 5-5 DCXO Pin Characteristics

Ball# ^[1]	Pin Name ^[2]	Type ^[3]	I/O Power Supply ^[4]
AH13	DXIN	AI	VCC-DCXO
AJ13	DXOUT	AO	VCC-DCXO
AH14	REFCLK-OUT	AO	VCC-DCXO
AE13	WREQIN	AI	VCC-PG
AA12	VCC-DCXO	P	N/A

5.2.5 USB2.0 DRD

Table 5-6 USB2.0 DRD Pin Characteristics

Ball# ^[1]	Pin Name ^[2]	Type ^[3]	I/O Power Supply ^[4]
A18	USB0-DP	A I/O	VCC33-USB
B18	USB0-DM	A I/O	VCC33-USB
E18	USB0-REXT	AO	VCC33-USB
H17	VCC33-USB	P	N/A
H18	VCC33-18-USB	P	N/A
H15	VDD09-USB	P	N/A

5.2.6 USB2.0 Host

Table 5-7 USB2.0 Host Pin Characteristics

Ball# ^[1]	Pin Name ^[2]	Type ^[3]	I/O Power Supply ^[4]
D20	USB1-DP	A I/O	VCC33-USB
E20	USB1-DM	A I/O	VCC33-USB
D18	USB1-REXT	AO	VCC33-USB

5.2.7 PCIe2.1&USB3.1 DRD

Table 5-8 PCIe2.1&USB3.1 DRD Pin Characteristics

Ball# ^[1]	Pin Name ^[2]	Type ^[3]	I/O Power Supply ^[4]
B17	USB2-DP	A I/O	VCC33-USB-2
C17	USB2-DM	A I/O	VCC33-USB-2
D16	USB2-REXT	AO	VCC33-USB-2
B14	PCIE-REF-CLKP	A I/O	VCC18-PCIE
C14	PCIE-REF-CLKN	A I/O	VCC18-PCIE
E14	PCIE-REXT	AO	VCC18-PCIE
A16	PCIE-RX0-DP/USB3-RXP	AI	VCC18-PCIE
B16	PCIE-RX0-DN/USB3-RXN	AI	VCC18-PCIE
B15	PCIE-TX0-DP/USB3-TXP	AO	VCC18-PCIE
C15	PCIE-TX0-DN/USB3-TXN	AO	VCC18-PCIE
J15	VCC33-USB-2	P	N/A
E16	VCC33-18-USB-2	P	N/A
H12	VCC18-PCIE	P	N/A

Ball# ^[1]	Pin Name ^[2]	Type ^[3]	I/O Power Supply ^[4]
H14	VDD09-PCIE	P	N/A

5.2.8 eDP1.3

Table 5-9 eDP1.3 Pin Characteristics

Ball# ^[1]	Pin Name ^[2]	Type ^[3]	I/O Power Supply ^[4]
B23	EDP-AUXP	A I/O	VCC18-EDP
C23	EDP-AUXN	A I/O	VCC18-EDP
E22	EDP-HPD	AI	VCC18-EDP
D22	EDP-REXT	AO	VCC18-EDP
B19	EDP-TX0P	AO	VCC18-EDP
C19	EDP-TX0N	AO	VCC18-EDP
A20	EDP-TX1P	AO	VCC18-EDP
B20	EDP-TX1N	AO	VCC18-EDP
B21	EDP-TX2P	AO	VCC18-EDP
C21	EDP-TX2N	AO	VCC18-EDP
A22	EDP-TX3P	AO	VCC18-EDP
B22	EDP-TX3N	AO	VCC18-EDP
H20	VCC18-EDP	P	N/A
H21	VDD09-EDP	P	N/A

5.2.9 Audio Codec

Table 5-10 Audio Codec Pin Characteristics

Ball# ^[1]	Pin Name ^[2]	Type ^[3]	I/O Power Supply ^[4]
AA2	MICIN1P	AI	AVCC
AA1	MICIN1N	AI	AVCC
AB2	MICIN2P	AI	AVCC
AB1	MICIN2N	AI	AVCC
AC2	MICIN3P	AI	AVCC
AC1	MICIN3N	AI	AVCC
AD2	LINEOUTLP	AO	AVCC
AD1	LINEOUTLN	AO	AVCC
AE2	LINEOUTRP	AO	AVCC

Ball# ^[1]	Pin Name ^[2]	Type ^[3]	I/O Power Supply ^[4]
AE1	LINEOUTRN	AO	AVCC
AH1	HPOUTL	AO	CPVIN
AJ2	HPOUTR	AO	CPVIN
AH2	HPOUTFB	AI	CPVIN
AF1	MIC-DET	AI	AVCC
AF2	HP-DET	AI	AVCC
AG1	MBIAS	AO	VDD33
AG2	HBIAS	AO	VDD33
AC4	VRA1	AO	AVCC
AC3	VRA2	AO	AVCC
AE5	CPVDD	P	N/A
AC5	CPVEE	P	N/A
AG3	CPVIN	P	N/A
W7	AVCC	P	N/A
AE3	ALDO-OUT	P	N/A
AA5	VDD33	P	N/A
AE4	VEE	P	N/A
AA4	VRP	P	N/A
AA3	AGND	G	N/A

5.2.10 GPADC

Table 5-11 GPADC Pin Characteristics

Ball# ^[1]	Pin Name ^[2]	Type ^[3]	I/O Power Supply ^[4]
W2	GPADC0	AI	AVCC
W3	GPADC1	AI	AVCC
W4	GPADC2	AI	AVCC
W5	GPADC3	AI	AVCC
U6	VCM-ADC	A I/O	AVCC
W6	VREFP-ADC	P	N/A
U7	VREFN-ADC	P	N/A

5.2.11 LRADC

Table 5-12 LRADC Pin Characteristics

Ball# ^[1]	Pin Name ^[2]	Type ^[3]	I/O Power Supply ^[4]
Y1	LRADC0	AI	AVCC
Y2	LRADC1	AI	AVCC

5.2.12 Power

Table 5-13 Power Pin Characteristics

Ball# ^[1]	Pin Name ^[2]	Type ^[3]
J12	VCC-IO	P
N23	VCC-EFUSE	P
Y12	VDD-CPUS	P
N16, N18, N19, P15, P16, P18, P19	VDD-CPUB	P
T16, T18, U16, U18	VDD-CPUL	P
M12, M14, M15	VDD-SYS	P
K10, L10	VDD-VE	P
K19, L18, L19	VDD-DE	P
N8, N10, P9, P10	VDD-GPU	P
U9, U10, V9, V10	VDD-DNR	P
M19	VDD-CPUBFB	P
V16	VDD-CPULFB	P
L15	VDD-SYSFB	P
W10	VDD-DNRFB	P

5.2.13 GPIO Groups

5.2.13.1 Port B

Table 5-14 Port B Pin Characteristics

Ball# ^[1]	Pin Name ^[2]	Type ^[3]	Ball Reset State ^[4]	Pull Up/Down ^[5]	Default Buffer Strength ^[6]	I/O Power Supply ^[7]
J24	PB0	I/O	Z	PU/PD	4 mA	VCC-IO
J25	PB1	I/O	Z	PU/PD	4 mA	VCC-IO

Ball# ^[1]	Pin Name ^[2]	Type ^[3]	Ball Reset State ^[4]	Pull Up/Down ^[5]	Default Buffer Strength ^[6]	I/O Power Supply ^[7]
H27	PB2	I/O	Z	PU/PD	4 mA	VCC-IO
H28	PB3	I/O	Z	PU/PD	4 mA	VCC-IO
J27	PB4	I/O	Z	PU/PD	4 mA	VCC-IO
J28	PB5	I/O	Z	PU/PD	4 mA	VCC-IO
J29	PB6	I/O	Z	PU/PD	4 mA	VCC-IO
K27	PB7	I/O	Z	PU/PD	4 mA	VCC-IO
K28	PB8	I/O	Z	PU/PD	4 mA	VCC-IO
L24	PB9	I/O	Z	PU/PD	4 mA	VCC-IO
PB10	PB10	I/O	Z	PU/PD	4 mA	VCC-IO
PB11	PB11	I/O	Z	PU/PD	4 mA	VCC-IO
PB12	PB12	I/O	Z	PU/PD	4 mA	VCC-IO
PB13	PB13	I/O	Z	PU/PD	4 mA	VCC-IO
PB14	PB14	I/O	Z	PU/PD	4 mA	VCC-IO

5.2.13.2 Port C

Table 5-15 Port C Pin Characteristics

Ball# ^[1]	Pin Name ^[2]	Type ^[3]	Ball Reset State ^[4]	Pull Up/Down ^[5]	Default Buffer Strength ^[6]	I/O Power Supply ^[7]
R24	PC0	I/O	Z	PU/PD	4 mA	VCC-PC
T27	PC1	I/O	Z	PU/PD	4 mA	VCC-PC
N26	PC2	I/O	Z	PU/PD	4 mA	VCC-PC
N25	PC3	I/O	Z	PU	4 mA	VCC-PC
N24	PC4	I/O	Z	PU	4 mA	VCC-PC
T28	PC5	I/O	Z	PU/PD	4 mA	VCC-PC
R29	PC6	I/O	Z	PU	4 mA	VCC-PC
R25	PC7	I/O	Z	PU	4 mA	VCC-PC
R28	PC8	I/O	Z	PU/PD	4 mA	VCC-PC
R27	PC9	I/O	Z	PU/PD	4 mA	VCC-PC
P28	PC10	I/O	Z	PU/PD	4 mA	VCC-PC
P27	PC11	I/O	Z	PU/PD	4 mA	VCC-PC
N29	PC12	I/O	Z	PU/PD	4 mA	VCC-PC

Ball# ^[1]	Pin Name ^[2]	Type ^[3]	Ball Reset State ^[4]	Pull Up/Down ^[5]	Default Buffer Strength ^[6]	I/O Power Supply ^[7]
N28	PC13	I/O	Z	PU/PD	4 mA	VCC-PC
N27	PC14	I/O	Z	PU/PD	4 mA	VCC-PC
M28	PC15	I/O	Z	PU/PD	4 mA	VCC-PC
M27	PC16	I/O	Z	PU/PD	4 mA	VCC-PC
N22	VCC-PC	P	N/A	N/A	N/A	N/A

5.2.13.3 Port D

Table 5-16 Port D Pin Characteristics

Ball# ^[1]	Pin Name ^[2]	Type ^[3]	Ball Reset State ^[4]	Pull Up/Down ^[5]	Default Buffer Strength ^[6]	I/O Power Supply ^[7]
A24	PD0	I/O	Z	PU/PD	4 mA	VCC-PD/VCC-LVDS0
B24	PD1	I/O	Z	PU/PD	4 mA	VCC-PD/VCC-LVDS0
A25	PD2	I/O	Z	PU/PD	4 mA	VCC-PD/VCC-LVDS0
B25	PD3	I/O	Z	PU/PD	4 mA	VCC-PD/VCC-LVDS0
A26	PD4	I/O	Z	PU/PD	4 mA	VCC-PD/VCC-LVDS0
B26	PD5	I/O	Z	PU/PD	4 mA	VCC-PD/VCC-LVDS0
A27	PD6	I/O	Z	PU/PD	4 mA	VCC-PD/VCC-LVDS0
B27	PD7	I/O	Z	PU/PD	4 mA	VCC-PD/VCC-LVDS0
A28	PD8	I/O	Z	PU/PD	4 mA	VCC-PD/VCC-LVDS0
B28	PD9	I/O	Z	PU/PD	4 mA	VCC-PD/VCC-LVDS0
C28	PD10	I/O	Z	PU/PD	4 mA	VCC-PD/VCC-LVDS0
C29	PD11	I/O	Z	PU/PD	4 mA	VCC-PD/VCC-LVDS0
D28	PD12	I/O	Z	PU/PD	4 mA	VCC-PD/VCC-LVDS0
D29	PD13	I/O	Z	PU/PD	4 mA	VCC-PD/VCC-LVDS0
E28	PD14	I/O	Z	PU/PD	4 mA	VCC-PD/VCC-LVDS0
E29	PD15	I/O	Z	PU/PD	4 mA	VCC-PD/VCC-LVDS0
E26	PD16	I/O	Z	PU/PD	4 mA	VCC-PD/VCC-LVDS0
E25	PD17	I/O	Z	PU/PD	4 mA	VCC-PD/VCC-LVDS0
F29	PD18	I/O	Z	PU/PD	4 mA	VCC-PD/VCC-LVDS0
F28	PD19	I/O	Z	PU/PD	4 mA	VCC-PD/VCC-LVDS0

Ball# ^[1]	Pin Name ^[2]	Type ^[3]	Ball Reset State ^[4]	Pull Up/Down ^[5]	Default Strength ^[6]	Buffer	I/O Power Supply ^[7]
G28	PD20	I/O	Z	PU/PD	4 mA		VCC-PD
G29	PD21	I/O	Z	PU/PD	4 mA		VCC-PD
G25	PD22	I/O	Z	PU/PD	4 mA		VCC-PD
G26	PD23	I/O	Z	PU/PD	4 mA		VCC-PD
J23	VCC-PD	P	N/A	N/A	N/A		N/A
K21	VCC-LVDS0	P	N/A	N/A	N/A		N/A

5.2.13.4 Port E

Table 5-17 Port E Pin Characteristics

Ball# ^[1]	Pin Name ^[2]	Type ^[3]	Ball Reset State ^[4]	Pull Up/Down ^[5]	Default Strength ^[6]	Buffer	I/O Power Supply ^[7]
J1	PE0	I/O	Z	PU/PD	4 mA		VCC-PE
J2	PE1	I/O	Z	PU/PD	4 mA		VCC-PE
K2	PE2	I/O	Z	PU/PD	4 mA		VCC-PE
K1	PE3	I/O	Z	PU/PD	4 mA		VCC-PE
L1	PE4	I/O	Z	PU/PD	4 mA		VCC-PE
L2	PE5	I/O	Z	PU/PD	4 mA		VCC-PE
M1	PE6	I/O	Z	PU/PD	4 mA		VCC-PE
M2	PE7	I/O	Z	PU/PD	4 mA		VCC-PE
J4	PE8	I/O	Z	PU/PD	4 mA		VCC-PE
J5	PE9	I/O	Z	PU/PD	4 mA		VCC-PE
N1	PE10	I/O	Z	PU/PD	4 mA		VCC-PE
N2	PE11	I/O	Z	PU/PD	4 mA		VCC-PE
L4	PE12	I/O	Z	PU/PD	4 mA		VCC-PE
L5	PE13	I/O	Z	PU/PD	4 mA		VCC-PE
N4	PE14	I/O	Z	PU/PD	4 mA		VCC-PE
N5	PE15	I/O	Z	PU/PD	4 mA		VCC-PE
J6	VCC_PE	P	N/A	N/A	N/A		N/A

5.2.13.5 Port F

Table 5-18 Port F Pin Characteristics

Ball# ^[1]	Pin Name ^[2]	Type ^[3]	Ball Reset State ^[4]	Pull Up/Down ^[5]	Default Strength ^[6]	Buffer	I/O Power Supply ^[7]
C13	PF0	I/O	Z	PU/PD	4 mA		VCC-IO/VCC-MCSI
B13	PF1	I/O	Z	PU/PD	4 mA		VCC-IO/VCC-MCSI
B12	PF2	I/O	Z	PU/PD	4 mA		VCC-IO/VCC-MCSI
A12	PF3	I/O	Z	PU/PD	4 mA		VCC-IO/VCC-MCSI
C11	PF4	I/O	Z	PU/PD	4 mA		VCC-IO/VCC-MCSI
B11	PF5	I/O	Z	PU/PD	4 mA		VCC-IO/VCC-MCSI
C12	PF6	I/O	Z	PU/PD	4 mA		VCC-IO/VCC-MCSI

5.2.13.6 Port G

Table 5-19 Port G Pin Characteristics

Ball# ^[1]	Pin Name ^[2]	Type ^[3]	Ball Reset State ^[4]	Pull Up/Down ^[5]	Default Strength ^[6]	Buffer	I/O Power Supply ^[7]
R1	PG0	I/O	Z	PU/PD	4 mA		VCC-PG
R2	PG1	I/O	Z	PU	4 mA		VCC-PG
P3	PG2	I/O	Z	PU	4 mA		VCC-PG
P2	PG3	I/O	Z	PU	4 mA		VCC-PG
T3	PG4	I/O	Z	PU	4 mA		VCC-PG
T2	PG5	I/O	Z	PU	4 mA		VCC-PG
R5	PG6	I/O	Z	PU/PD	4 mA		VCC-PG
U3	PG7	I/O	Z	PU/PD	4 mA		VCC-PG
R4	PG8	I/O	Z	PU/PD	4 mA		VCC-PG
U4	PG9	I/O	Z	PU/PD	4 mA		VCC-PG
U1	PG10	I/O	Z	PU/PD	4 mA		VCC-PG
U2	PG11	I/O	Z	PU/PD	4 mA		VCC-PG
V2	PG12	I/O	Z	PU/PD	4 mA		VCC-PG
V3	PG13	I/O	Z	PU/PD	4 mA		VCC-PG
U5	PG14	I/O	Z	PU/PD	4 mA		VCC-PG
N6	VCC-PG	P	N/A	N/A	N/A		N/A

5.2.13.7 Port H

Table 5-20 Port H Pin Characteristics

Ball# ^[1]	Pin Name ^[2]	Type ^[3]	Ball Reset State ^[4]	Pull Up/Down ^[5]	Default Strength ^[6]	Buffer	I/O Power Supply ^[7]
F10	PH0	I/O	Z	PU/PD	4 mA		VCC-IO
E10	PH1	I/O	Z	PU/PD	4 mA		VCC-IO
D10	PH2	I/O	Z	PU/PD	4 mA		VCC-IO
B10	PH3	I/O	Z	PU/PD	4 mA		VCC-IO
A10	PH4	I/O	Z	PU/PD	4 mA		VCC-IO
B9	PH5	I/O	Z	PU/PD	4 mA		VCC-IO
C9	PH6	I/O	Z	PU/PD	4 mA		VCC-IO
F8	PH7	I/O	Z	PU/PD	4 mA		VCC-IO
E8	PH8	I/O	Z	PU/PD	4 mA		VCC-IO
D8	PH9	I/O	Z	PU/PD	4 mA		VCC-IO
B8	PH10	I/O	Z	PU/PD	4 mA		VCC-IO
A8	PH11	I/O	Z	PU/PD	4 mA		VCC-IO
C7	PH12	I/O	Z	PU/PD	4 mA		VCC-IO
B7	PH13	I/O	Z	PU/PD	4 mA		VCC-IO
A6	PH14	I/O	Z	PU/PD	4 mA		VCC-IO
B6	PH15	I/O	Z	PU/PD	4 mA		VCC-IO
A5	PH16	I/O	Z	PU/PD	4 mA		VCC-IO
B5	PH17	I/O	Z	PU/PD	4 mA		VCC-IO
D6	PH18	I/O	Z	PU/PD	4 mA		VCC-IO
E6	PH19	I/O	Z	PU/PD	4 mA		VCC-IO

5.2.13.8 Port K

Table 5-21 Port K Pin Characteristics

Ball# ^[1]	Pin Name ^[2]	Type ^[3]	Ball Reset State ^[4]	Pull Up/Down ^[5]	Default Strength ^[6]	Buffer	I/O Power Supply ^[7]
A4	PK0	I/O	Z	PU/PD	4 mA		VCC-PK/VCC-MCSI
B4	PK1	I/O	Z	PU/PD	4 mA		VCC-PK/VCC-MCSI
A3	PK2	I/O	Z	PU/PD	4 mA		VCC-PK/VCC-MCSI

Ball# ^[1]	Pin Name ^[2]	Type ^[3]	Ball Reset State ^[4]	Pull Up/Down ^[5]	Default Strength ^[6]	Buffer	I/O Power Supply ^[7]
B3	PK3	I/O	Z	PU/PD	4 mA		VCC-PK/VCC-MCSI
B2	PK4	I/O	Z	PU/PD	4 mA		VCC-PK/VCC-MCSI
B1	PK5	I/O	Z	PU/PD	4 mA		VCC-PK/VCC-MCSI
C5	PK6	I/O	Z	PU/PD	4 mA		VCC-PK/VCC-MCSI
C4	PK7	I/O	Z	PU/PD	4 mA		VCC-PK/VCC-MCSI
E5	PK8	I/O	Z	PU/PD	4 mA		VCC-PK/VCC-MCSI
E4	PK9	I/O	Z	PU/PD	4 mA		VCC-PK/VCC-MCSI
G5	PK10	I/O	Z	PU/PD	4 mA		VCC-PK/VCC-MCSI
G4	PK11	I/O	Z	PU/PD	4 mA		VCC-PK/VCC-MCSI
C2	PK12	I/O	Z	PU/PD	4 mA		VCC-PK/VCC-MCSI
C1	PK13	I/O	Z	PU/PD	4 mA		VCC-PK/VCC-MCSI
D2	PK14	I/O	Z	PU/PD	4 mA		VCC-PK/VCC-MCSI
D1	PK15	I/O	Z	PU/PD	4 mA		VCC-PK/VCC-MCSI
E2	PK16	I/O	Z	PU/PD	4 mA		VCC-PK/VCC-MCSI
E1	PK17	I/O	Z	PU/PD	4 mA		VCC-PK/VCC-MCSI
F1	PK18	I/O	Z	PU/PD	4 mA		VCC-PK/VCC-MCSI
F2	PK19	I/O	Z	PU/PD	4 mA		VCC-PK/VCC-MCSI
G2	PK20	I/O	Z	PU/PD	4 mA		VCC-PK/VCC-MCSI
G1	PK21	I/O	Z	PU/PD	4 mA		VCC-PK/VCC-MCSI
H2	PK22	I/O	Z	PU/PD	4 mA		VCC-PK/VCC-MCSI
H1	PK23	I/O	Z	PU/PD	4 mA		VCC-PK/VCC-MCSI
J7	VCC-PK	P	N/A	N/A	N/A		N/A
H10	VCC-MCSI	P	N/A	N/A	N/A		N/A

5.2.13.9 Port L

Table 5-22 Port L Pin Characteristics

Ball# ^[1]	Pin Name ^[2]	Type ^[3]	Ball Reset State ^[4]	Pull Up/Down ^[5]	Default Strength ^[6]	Buffer	I/O Power Supply ^[7]
AJ7	PL0	I/O	Z	PU	4 mA		VCC-PL
AH7	PL1	I/O	Z	PU	4 mA		VCC-PL
AJ8	PL2	I/O	Z	PU/PD	4 mA		VCC-PL

Ball# ^[1]	Pin Name ^[2]	Type ^[3]	Ball Reset State ^[4]	Pull Up/Down ^[5]	Default Strength ^[6]	Buffer	I/O Supply ^[7]	Power
AH8	PL3	I/O	Z	PU/PD	4 mA		VCC-PL	
AH9	PL4	I/O	Z	PU/PD	4 mA		VCC-PL	
AJ9	PL5	I/O	Z	PU/PD	4 mA		VCC-PL	
AE9	PL6	I/O	Z	PU/PD	4 mA		VCC-PL	
AF9	PL7	I/O	Z	PU/PD	4 mA		VCC-PL	
AG10	PL8	I/O	Z	PU/PD	4 mA		VCC-PL	
AG9	PL9	I/O	Z	PU/PD	4 mA		VCC-PL	
AC9	PL10	I/O	Z	PU/PD	4 mA		VCC-PL	
AD9	PL11	I/O	Z	PU/PD	4 mA		VCC-PL	
AF7	PL12	I/O	Z	PU/PD	4 mA		VCC-PL	
AE7	PL13	I/O	Z	PU/PD	4 mA		VCC-PL	
AA9	VCC-PL	P	N/A	N/A	N/A		N/A	

5.2.13.10 Port M

Table 5-23 Port M Pin Characteristics

Ball# ^[1]	Pin Name ^[2]	Type ^[3]	Ball Reset State ^[4]	Pull Up/Down ^[5]	Default Strength ^[6]	Buffer	I/O Supply ^[7]	Power
AJ4	PM0	I/O	Z	PU/PD	4 mA		VCC-PM	
AJ3	PM1	I/O	Z	PU/PD	4 mA		VCC-PM	
AH5	PM2	I/O	Z	PU/PD	4 mA		VCC-PM	
AH4	PM3	I/O	Z	PU/PD	4 mA		VCC-PM	
AJ5	PM4	I/O	Z	PU/PD	4 mA		VCC-PM	
AH6	PM5	I/O	Z	PU/PD	4 mA		VCC-PM	
AC7	VCC-PM	P	N/A	N/A	N/A		N/A	

5.2.14 Ground

Table 5-24 Ground Pin Characteristics

Ball# ^[1]	Pin Name ^[2]	Type ^[3]
A14, C16, C18, C20, C22, D14, F16, F18, F20, F22, H13, H16, H19, J13, J16, J18, J19	AVSS	G
A1, A2, A29, B29, C3, C6, C8, C10, C24, C25, C26, C27, D12, E3, E24, E27, G3, G6, G7, G23, G24, G27, H9, H11, J3, J10, J22, J26, K9, K12, K15, K16, K18, L3, L6, L7, L9, L13, L16, L21, L23, M9, M10, M16, M21, N3, N7, N12, N13, N15, N21, P11, P13, R3, R6, R7, R15, R16, R23, R26, T9, T10, T12, T13, T19, U12, U15, U19, U20, U26, U28, V12, V13, V15, V18, V19, W1, W8, W9, W12, W14, W25, W29, AA6, AA7, AA11, AA17, AA18, AA19, AA20, AA25, AA28, AC13, AC21, AC24, AC27, AC29, AD7, AD23, AD28, AE15, AE17, AE19, AF11, AF13, AF28, AG5, AG7, AG12, AG13, AG14, AH3, AH10, AH16, AH22, AH25, AJ1, AJ6, AJ11, AJ18, AJ20, AJ24, AJ27, AJ29	GND	G

5.2.15 Others

Ball# ^[1]	Pin Name ^[2]
F14	NC

5.3 GPIO Multiplex Function

The following tables provide a description of the A523 GPIO multiplex function.



NOTE

For each GPIO, Function0 is input function; Function1 is output function; Function7 to Function13 are reserved.

5.3.1 Port B

Table 5-25 Port B Multiplex Function

Pin Name	IO Type	Function2	Function3	Function4	Function5	Function6	Function14
PB0	I/O	UART2-TX	SPI2-CS0	JTAG-MS	LCD0-D0	PWM6	PB-EINT0
PB1	I/O	UART2-RX	SPI2-CLK	JTAG-CK	LCD0-D1	PWM7	PB-EINT1
PB2	I/O	UART2-RTS	SPI2-MOSI	JTAG-DO	LCD0-D8		PB-EINT2
PB3	I/O	UART2-CTS	SPI2-MISO	JTAG-DI	LCD0-D9		PB-EINT3
PB4	I/O	TWI1-SCK	I2S0-MCLK		PWM8		PB-EINT4
PB5	I/O	TWI1-SDA	I2S0-BCLK		PWM9		PB-EINT5
PB6	I/O		I2S0-LRCK		PWM10		PB-EINT6
PB7	I/O	OWA-IN	I2S0-DOUT0	I2S0-DIN1	LCD0-D16	PWM11	PB-EINT7
PB8	I/O	OWA-OUT	I2S0-DIN0	I2S0-DOUT1	LCD0-D17	PWM0	PB-EINT8
PB9	I/O	UART0-TX	TWI0-SCK		I2S0-DIN2	I2S0-DOUT2	PB-EINT9
PB10	I/O	UART0-RX	TWI0-SDA	PWM1	I2S0-DIN3	I2S0-DOUT3	PB-EINT10
PB11	I/O	TWI5-SCK	UART7-RTS	SPI1-CS0	PWM2		PB-EINT11
PB12	I/O	TWI5-SDA	UART7-CTS	SPI1-CLK	PWM3		PB-EINT12
PB13	I/O	TWI4-SCK	UART7-TX	SPI1-MOSI	PWM4		PB-EINT13
PB14	I/O	TWI4-SDA	UART7-RX	SPI1-MISO	PWM5		PB-EINT14

5.3.2 Port C

Table 5-26 Port C Multiplex Function

Pin Name	IO Type	Function2	Function3	Function4	Function5	Function6	Function14
PC0	I/O	NAND-WE	SDC2-DS				PC-EINT0
PC1	I/O	NAND-ALE	SDC2-RST				PC-EINT1
PC2	I/O	NAND-CLE		SPI0-MOSI	SPIF-MOSI		PC-EINT2

Pin Name	IO Type	Function2	Function3	Function4	Function5	Function6	Function14
PC3	I/O	NAND-CE1		SPI0-CS0	SPIF-CS0		PC-EINT3
PC4	I/O	NAND-CE0		SPI0-MISO	SPIF-MISO		PC-EINT4
PC5	I/O	NAND-RE	SDC2-CLK				PC-EINT5
PC6	I/O	NAND-RB0	SDC2-CMD				PC-EINT6
PC7	I/O	NAND-RB1		SPI0-CS1	SPIF-DQS		PC-EINT7
PC8	I/O	NAND-DQ7	SDC2-D3		SPIF-D7		PC-EINT8
PC9	I/O	NAND-DQ6	SDC2-D4		SPIF-D6		PC-EINT9
PC10	I/O	NAND-DQ5	SDC2-D0		SPIF-D5		PC-EINT10
PC11	I/O	NAND-DQ4	SDC2-D5		SPIF-D4		PC-EINT11
PC12	I/O	NAND-DQS		SPI0-CLK	SPIF-CLK		PC-EINT12
PC13	I/O	NAND-DQ3	SDC2-D1				PC-EINT13
PC14	I/O	NAND-DQ2	SDC2-D6				PC-EINT14
PC15	I/O	NAND-DQ1	SDC2-D2	SPI0-WP	SPIF-WP		PC-EINT15
PC16	I/O	NAND-DQ0	SDC2-D7	SPI0-HOLD	SPIF-HOLD		PC-EINT16

5.3.3 Port D

Table 5-27 Port D Multiplex Function

Pin Name	IO Type	Function2	Function3	Function4	Function5	Function6	Function14
PD0	I/O	LCD0-D2	LVDS0-D0P	DSI0-D0P	PWM0		PD-EINT0
PD1	I/O	LCD0-D3	LVDS0-D0N	DSI0-D0N	PWM1		PD-EINT1
PD2	I/O	LCD0-D4	LVDS0-D1P	DSI0-D1P	PWM2		PD-EINT2
PD3	I/O	LCD0-D5	LVDS0-D1N	DSI0-D1N	PWM3		PD-EINT3
PD4	I/O	LCD0-D6	LVDS0-D2P	DSI0-CKP	PWM4		PD-EINT4
PD5	I/O	LCD0-D7	LVDS0-D2N	DSI0-CKN	PWM5		PD-EINT5
PD6	I/O	LCD0-D10	LVDS0-CKP	DSI0-D2P	PWM6		PD-EINT6
PD7	I/O	LCD0-D11	LVDS0-CKN	DSI0-D2N	PWM7		PD-EINT7
PD8	I/O	LCD0-D12	LVDS0-D3P	DSI0-D3P	PWM8		PD-EINT8
PD9	I/O	LCD0-D13	LVDS0-D3N	DSI0-D3N	PWM9		PD-EINT9
PD10	I/O	LCD0-D14	LVDS1-D0P	DSI1-D0P	PWM10	SPI1-CS0/DBI-CSX	PD-EINT10
PD11	I/O	LCD0-D15	LVDS1-D0N	DSI1-D0N	PWM11	SPI1-CLK/DBI-SCLK	PD-EINT11
PD12	I/O	LCD0-D18	LVDS1-D1P	DSI1-D1P	PWM12	SPI1-MOSI/DBI-SDO	PD-EINT12
PD13	I/O	LCD0-D19	LVDS1-D1N	DSI1-D1N	PWM13	SPI1-MISO/DBI-SDI/DBI-T E/DBI-DCX	PD-EINT13
PD14	I/O	LCD0-D20	LVDS1-D2P	DSI1-CKP	PWM14	UART3-TX	PD-EINT14
PD15	I/O	LCD0-D21	LVDS1-D2N	DSI1-CKN	PWM15	UART3-RX	PD-EINT15
PD16	I/O	LCD0-D22	LVDS1-CKP	DSI1-D2P	PWM16	UART3-RTS	PD-EINT16
PD17	I/O	LCD0-D23	LVDS1-CKN	DSI1-D2N	PWM17	UART3-CTS	PD-EINT17
PD18	I/O	LCD0-CLK	LVDS1-D3P	DSI1-D3P	PWM18	UART4-TX	PD-EINT18
PD19	I/O	LCD0-DE	LVDS1-D3N	DSI1-D3N	PWM19	UART4-RX	PD-EINT19
PD20	I/O	LCD0-HSYNC	PWM2	UART2-TX	UART7-RTS	UART4-RTS	PD-EINT20
PD21	I/O	LCD0-VSYNC	PWM3	UART2-RX	UART7-CTS	UART4-CTS	PD-EINT21
PD22	I/O	PWM1	SPI1-HOLD/DBI-DCX/DBI -WRX	UART2-RTS	UART7-TX	TWI0-SCK	PD-EINT22
PD23	I/O	PWM0	SPI1-WP/DBI-TE	UART2-CTS	UART7-RX	TWI0-SDA	PD-EINT23

5.3.4 Port E

Table 5-28 Port E Multiplex Function

Pin Name	IO Type	Function2	Function3	Function4	Function5	Function6	Function14
PE0	I/O	MCSI0-MCLK					PE-EINT0

Pin Name	IO Type	Function2	Function3	Function4	Function5	Function6	Function14
PE1	I/O	TWI2-SCK	UART4-TX				PE-EINT1
PE2	I/O	TWI2-SDA	UART4-RX				PE-EINT2
PE3	I/O	TWI3-SCK	UART4-RTS				PE-EINT3
PE4	I/O	TWI3-SDA	UART4-CTS				PE-EINT4
PE5	I/O	MCSI1-MCLK		I2S2-MCLK	LEDC		PE-EINT5
PE6	I/O			I2S2-BCLK	LCD0-TRIG	NCSI-D8	PE-EINT6
PE7	I/O			I2S2-LRCK	LCD1-TRIG	NCSI-D9	PE-EINT7
PE8	I/O			I2S2-DOUT0		NCSI-D10	PE-EINT8
PE9	I/O			I2S2-DIN0		NCSI-D11	PE-EINT9
PE10	I/O	MCSI3-MCLK	PWM3			NCSI-D12	PE-EINT10
PE11	I/O	TWI1-SCK	UART5-RTS	SPI2-CS0	UART6-TX	NCSI-D13	PE-EINT11
PE12	I/O	TWI1-SDA	UART5-CTS	SPI2-CLK	UART6-RX	NCSI-D14	PE-EINT12
PE13	I/O	TWI4-SCK	UART5-TX	SPI2-MOSI	UART6-RTS	CSI0-XVS-FSYNC	PE-EINT13
PE14	I/O	TWI4-SDA	UART5-RX	SPI2-MISO	UART6-CTS	CSI1-XVS-FSYNC	PE-EINT14
PE15	I/O	MCSI2-MCLK	PWM2			NCSI-D15	PE-EINT15

5.3.5 Port F

Table 5-29 Port F Multiplex Function

Pin Name	IO Type	Function2	Function3	Function4	Function5	Function6	Function14
PF0	I/O	SDC0-D1	JTAG-MS		I2S3-DIN0	I2S3-DOUT1	PF-EINT0
PF1	I/O	SDC0-D0	JTAG-DI		I2S3-DOUT0	I2S3-DIN1	PF-EINT1
PF2	I/O	SDC0-CLK	UART0-TX		I2S3-DIN2	I2S3-DOUT2	PF-EINT2
PF3	I/O	SDC0-CMD	JTAG-DO		I2S3-LRCK		PF-EINT3
PF4	I/O	SDC0-D3	UART0-RX		I2S3-DIN3	I2S3-DOUT3	PF-EINT4
PF5	I/O	SDC0-D2	JTAG-CK		I2S3-BCLK		PF-EINT5
PF6	I/O				I2S3-MCLK		PF-EINT6

5.3.6 Port G

Table 5-30 Port G Multiplex Function

Pin Name	IO Type	Function2	Function3	Function4	Function5	Function6	Function14
PG0	I/O	SDC1-CLK					PG-EINT0
PG1	I/O	SDC1-CMD					PG-EINT1
PG2	I/O	SDC1-D0	PCIE0-PERSTN				PG-EINT2
PG3	I/O	SDC1-D1	PCIE0-WAKEN				PG-EINT3
PG4	I/O	SDC1-D2	PCIE0-CLKREQN				PG-EINT4
PG5	I/O	SDC1-D3					PG-EINT5
PG6	I/O	UART1-TX					PG-EINT6
PG7	I/O	UART1-RX					PG-EINT7
PG8	I/O	UART1-RTS					PG-EINT8
PG9	I/O	UART1-CTS					PG-EINT9
PG10	I/O		I2S1-MCLK				PG-EINT10
PG11	I/O		I2S1-BCLK				PG-EINT11
PG12	I/O		I2S1-LRCK				PG-EINT12
PG13	I/O		I2S1-DOUT0	I2S1-DIN1			PG-EINT13
PG14	I/O		I2S1-DIN0	I2S1-DOUT1			PG-EINT14

5.3.7 Port H

Table 5-31 Port H Multiplex Function

Pin Name	IO Type	Function2	Function3	Function4	Function5	Function6	Function14
----------	---------	-----------	-----------	-----------	-----------	-----------	------------

Pin Name	IO Type	Function2	Function3	Function4	Function5	Function6	Function14
PH0	I/O	TWI0-SCK			RGMIIO-RXD1/RMII0-RXD1		PH-EINT0
PH1	I/O	TWI0-SDA			RGMIIO-RXD0/RMII0-RXD0		PH-EINT1
PH2	I/O	TWI1-SCK		I2S2-DIN3	RGMIIO-RXCTL/RMII0-CRS-DV	I2S2-DOUT3	PH-EINT2
PH3	I/O	TWI1-SDA	IR-TX	I2S2-DIN2	RGMIIO-CLKIN/RMII0-RXER	I2S2-DOUT2	PH-EINT3
PH4	I/O	UART3-TX	SPI1-CS0		RGMIIO-TXD1/RMII0-TXD1		PH-EINT4
PH5	I/O	UART3-RX	SPI1-CLK	LEDC	RGMIIO-TXD0/RMII0-TXD0		PH-EINT5
PH6	I/O	UART3-RTS	SPI1-MOSI	OWA-IN	RGMIIO-TXCK/RMII0-TXCK		PH-EINT6
PH7	I/O	UART3-CTS	SPI1-MISO	OWA-OUT	RGMIIO-TXCTL/RMII0-TXEN		PH-EINT7
PH8	I/O	DMIC-CLK	SPI2-CS0	I2S2-MCLK	I2S2-DIN2		PH-EINT8
PH9	I/O	DMIC-DATA0	SPI2-CLK	I2S2-BCLK	RGMIIO-MDC		PH-EINT9
PH10	I/O	DMIC-DATA1	SPI2-MOSI	I2S2-LRCK	RGMIIO-MDIO		PH-EINT10
PH11	I/O	DMIC-DATA2	SPI2-MISO	I2S2-DOUT0	I2S2-DIN1	PCIE0-PERSTN	PH-EINT11
PH12	I/O	DMIC-DATA3	TWI3-SCK	I2S2-DIN0	I2S2-DOUT1	PCIE0-WAKEN	PH-EINT12
PH13	I/O		TWI3-SDA	I2S3-MCLK	RGMIIO-EPHY-25M		PH-EINT13
PH14	I/O			I2S3-BCLK	RGMIIO-RXD3/RMII0-NULL		PH-EINT14
PH15	I/O			I2S3-LRCK	RGMIIO-RXD2/RMII0-NULL		PH-EINT15
PH16	I/O		I2S3-DOUT0	I2S3-DIN1	RGMIIO-RXCK/RMII0-NULL	CLK-FANOUT0	PH-EINT16
PH17	I/O		I2S3-DOUT1	I2S3-DIN0	RGMIIO-TXD3/RMII0-NULL		PH-EINT17
PH18	I/O	IR-TX	I2S3-DOUT2	I2S3-DIN2	RGMIIO-TXD2/RMII0-NULL		PH-EINT18
PH19	I/O	IR-RX	I2S3-DOUT3	I2S3-DIN3	LEDC	PCIE0-CLKREQN	PH-EINT19

5.3.8 Port K

Table 5-32 Port K Multiplex Function

Pin Name	IO Type	Function2	Function3	Function4	Function5	Function6	Function14
PK0	I/O	MCSIA-D0N					PK-EINT0
PK1	I/O	MCSIA-D0P					PK-EINT1
PK2	I/O	MCSIA-D1N					PK-EINT2
PK3	I/O	MCSIA-D1P					PK-EINT3
PK4	I/O	MCSIA-CKN	TWI2-SCK				PK-EINT4
PK5	I/O	MCSIA-CKP	TWI2-SDA				PK-EINT5
PK6	I/O	MCSIB-D0N					PK-EINT6
PK7	I/O	MCSIB-D0P					PK-EINT7
PK8	I/O	MCSIB-D1N					PK-EINT8
PK9	I/O	MCSIB-D1P					PK-EINT9
PK10	I/O	MCSIB-CKN	TWI3-SCK				PK-EINT10
PK11	I/O	MCSIB-CKP	TWI3-SDA				PK-EINT11
PK12	I/O	MCSIC-D0N	UART7-TX	TWI4-SCK	NCSI-PCLK		PK-EINT12
PK13	I/O	MCSIC-D0P	UART7-RX	TWI4-SDA	NCSI-MCLK		PK-EINT13
PK14	I/O	MCSIC-D1N	UART7-RTS	UART5-RTS	NCSI-HSYNC		PK-EINT14
PK15	I/O	MCSIC-D1P	UART7-CTS	UART5-CTS	NCSI-VSYNC		PK-EINT15
PK16	I/O	MCSIC-CKN	TWI5-SCK	UART5-TX	NCSI-D0		PK-EINT16
PK17	I/O	MCSIC-CKP	TWI5-SDA	UART5-RX	NCSI-D1		PK-EINT17
PK18	I/O	MCSID-D0N	MCSI0-MCLK	UART6-TX	NCSI-D2		PK-EINT18
PK19	I/O	MCSID-D0P	TWI2-SCK	UART6-RX	NCSI-D3		PK-EINT19
PK20	I/O	MCSID-D1N	TWI2-SDA	UART6-RTS	NCSI-D4		PK-EINT20
PK21	I/O	MCSID-D1P	MCSI1-MCLK	UART6-CTS	NCSI-D5		PK-EINT21
PK22	I/O	MCSID-CKN	TWI3-SCK	PWM6	NCSI-D6		PK-EINT22
PK23	I/O	MCSID-CKP	TWI3-SDA	PWM7	NCSI-D7		PK-EINT23

5.3.9 Port L

Table 5-33 Port L Multiplex Function

Pin Name	IO Type	Function2	Function3	Function4	Function5	Function6	Function14
PL0	I/O	S-TWI0-SCK					PL-EINT0
PL1	I/O	S-TWI0-SDA					PL-EINT1
PL2	I/O	S-UART0-TX	S-UART1-TX	S-PWM2			PL-EINT2
PL3	I/O	S-UART0-RX	S-UART1-RX	S-PWM3			PL-EINT3
PL4	I/O	S-JTAG-MS		S-PWM4	S-I2S0-BCLK		PL-EINT4
PL5	I/O	S-JTAG-CK		S-PWM5	S-I2S0-LRCK	S-DMIC-DATA3	PL-EINT5
PL6	I/O	S-JTAG-DO	S-PWM6	S-I2S0-DIN1	S-I2S0-DOUT0	S-DMIC-DATA2	PL-EINT6
PL7	I/O	S-JTAG-DI	S-PWM7	S-I2S0-DOUT1	S-I2S0-DIN0	S-DMIC-DATA1	PL-EINT7
PL8	I/O	S-TWI1-SCK		S-RJTAG-MS	S-I2S0-MCLK	S-DMIC-DATA0	PL-EINT8
PL9	I/O	S-TWI1-SDA		S-RJTAG-CK	S-PWM1	S-DMIC-CLK	PL-EINT9
PL10	I/O	S-PWM0		S-RJTAG-DO	S-DMIC-DATA0	S-SPI0-CS0	PL-EINT10
PL11	I/O	S-IR-RX		S-RJTAG-DI	S-DMIC-DATA1	S-SPI0-CLK	PL-EINT11
PL12	I/O	S-TWI2-SCK	S-PWM8	S-UART0-TX	S-DMIC-DATA2	S-SPI0-MOSI	PL-EINT12
PL13	I/O	S-TWI2-SDA	S-PWM9	S-UART0-RX	S-DMIC-DATA3	S-SPI0-MISO	PL-EINT13

5.3.10 Port M

Table 5-34 Port M Multiplex Function

Pin Name	IO Type	Function2	Function3	Function4	Function5	Function6	Function14
PM0	I/O	S-UART0-TX	S-UART1-TX	S-PWM2			PM-EINT0
PM1	I/O	S-UART0-RX	S-UART1-RX	S-PWM3			PM-EINT1
PM2	I/O	S-TWI1-SCK	S-RJTAG-MS	S-PWM6			PM-EINT2
PM3	I/O	S-TWI1-SDA	S-RJTAG-CK	S-PWM7			PM-EINT3
PM4	I/O	S-PWM8	S-RJTAG-DO	S-TWI2-SCK			PM-EINT4
PM5	I/O	S-IR-RX	S-RJTAG-DI	S-TWI2-SDA	S-PWM9		PM-EINT5

5.4 Detailed Signal Description

The following tables show the detailed function description of every signal based on the different interfaces.

[1] **Signal Name:** The name of every signal.

[2] **Description:** The detailed function description of every signal.

[3] **Type:** Denotes the signal direction:

I (Input),

O (Output),

I/O (Input/Output),

OD (Open-Drain),

A (Analog),

AI (Analog Input),

AO (Analog Output),

A I/O (Analog Input/Output),

P (Power),

G (Ground)

5.4.1 Audio Codec

Table 5-35 Audio Codec Signal Description

Signal Name ^[1]	Description ^[2]	Type ^[3]
MICIN1P	Microphone Differential Positive Input 1	AI
MICIN1N	Microphone Differential Negative Input 1	AI
MICIN2P	Microphone Differential Positive Input 2	AI
MICIN2N	Microphone Differential Negative Input 2	AI
MICIN3P	Microphone Differential Positive Input 3	AI
MICIN3N	Microphone Differential Negative Input 3	AI
LINEOUTLP	Lineout Left Channel Positive Differential Output	AO
LINEOUTLN	Lineout Left Channel Negative Differential Output	AO
LINEOUTRP	Lineout Right Channel Positive Differential Output	AO
LINEOUTRN	Lineout Right Channel Negative Differential Output	AO
HPOUTL	Headphone Left Output	AO

Signal Name ^[1]	Description ^[2]	Type ^[3]
HPOUTR	Headphone Right Output	AO
HPOUTFB	Pseudo Differential Headphone Ground Reference	AI
MIC-DET	Headphone MIC detect	AI
HP-DET	Headphone Jack detect	AI
MBIAS	First bias voltage output for main microphone	AO
HBIAS	Second bias voltage output for headset microphone	AO
CPVDD	Analog power for headphone charge pump	P
CPVEE	Charge pump negative voltage output	P
CPVIN	Analog power for LDO	P
AVCC	Power Supply for Analog Part	P
ALDO-OUT	Power Supply for AVCC	P
VDD33	Power Supply for 3.3V Analog Part	P
VEE	Negative Voltage to Headphone	P
VRA1	Internal Reference Voltage	AO
VRA2	Internal Reference Voltage	AO
VRP	Internal Reference Voltage	AO
AGND	Analog Ground	G

5.4.2 CIR_RX

Table 5-36 CIR_RX Signal Description

Signal Name ^[1]	Description ^[2]	Type ^[3]
IR-RX	Consumer Infrared Receiver	I
S-IR-RX	Consumer infrared Receiver	I

5.4.3 CIR_TX

Table 5-37 CIR_TX Signal Description

Signal Name ^[1]	Description ^[2]	Type ^[3]
IR-TX	Consumer Infrared Transmitter	O

5.4.4 DCXO

Table 5-38 DCXO Signal Description

Signal Name ^[1]	Description ^[2]	Type ^[3]
----------------------------	----------------------------	---------------------

Signal Name ^[1]	Description ^[2]	Type ^[3]
DXIN	Digital Compensated Crystal Oscillator Input	AI
DXOUT	Digital Compensated Crystal Oscillator Output	AO
REFCLK-OUT	Digital Compensated Crystal Oscillator Clock Fanout	AO
WREQIN	Request signal of REFCLK_OUT	AI
VCC-DCXO	Digital Compensated Crystal Oscillator Power Supply	P

5.4.5 DMIC

Table 5-39 DMIC Signal Description

Signal Name ^[1]	Description ^[2]	Type ^[3]
DMIC-DATA[3:0]	Digital Microphone Data Input	I
DMIC-CLK	Digital Microphone Clock Output	O
S-DMIC-DATA[3:0]	Digital Microphone Data Input	I
S-DMIC-CLK	Digital Microphone Clock Output	O

5.4.6 eDP1.3

Table 5-40 eDP1.3 Signal Description

Signal Name ^[1]	Description ^[2]	Type ^[3]
EDP-AUXP	AUX channel Positive Input/Output	A I/O
EDP-AUXN	AUX channel Negative Input/Output	A I/O
EDP-HPD	Hot Plug Detection Signal	AI
EDP-REXT	eDP External Reference Resistor	AO
EDP-TX0P	eDP Positive Output of Data Channel0	AO
EDP-TX0N	eDP Negative Output of Data Channel0	AO
EDP-TX1P	eDP Positive Output of Data Channel1	AO
EDP-TX1N	eDP Negative Output of Data Channel1	AO
EDP-TX2P	eDP Positive Output of Data Channel2	AO
EDP-TX2N	eDP Negative Output of Data Channel2	AO
EDP-TX3P	eDP Positive Output of Data Channel3	AO
EDP-TX3N	eDP Negative Output of Data Channel3	AO
VCC18-EDP	1.8V Analog Supply	P
VDD09-EDP	0.9V Digital Supply	P

5.4.7 GMAC

Table 5-41 GMAC Signal Description

Signal Name ^[1]	Description ^[2]	Type ^[3]
RGMII0-RXD0/RMII0-RXD0	RGMII/RMII Receive Data0	I
RGMII0-RXD1/RMII0-RXD1	RGMII/RMII Receive Data1	I
RGMII0-RXD2/RMII0-NULL	RGMII Receive Data2	I
RGMII0-RXD3/RMII0-NULL	RGMII Receive Data3	I
RGMII0-RXCK/ RMII0-NULL	RGMII Receive Clock	I
RGMII0-RXCTRL/RMII0-CRS-DV	RGMII Receive Control/RMII Carrier Sense Receive Data Valid	I
RGMII0-CLKIN/RMII0-RXER	RGMII Transmit Clock from External/RMII Receive Error	I
RGMII0-TXD0/RMII0-TXD0	RGMII/RMII Transmit Data0	O
RGMII0-TXD1/RMII0-TXD1	RGMII/RMII Transmit Data1	O
RGMII0-TXD2/RMII0-NULL	RGMII Transmit Data2	O
RGMII0-TXD3/RMII0-NULL	RGMII Transmit Data3	O
RGMII0-TXCK/RMII0-TXCK	RGMII/RMII Transmit Clock For RGMII, IO type is output; For RMII, IO type is input	I/O
RGMII0-TXCTRL/RMII0-TXEN	RGMII Transmit Control/RMII Transmit Enable	O
RGMII0-MDC	RGMII Management Data Clock	O
RGMII0-MDIO	RGMII Management Data Input/ Output	I/O
RGMII0-EPHY-25M	25 MHz Output for GMAC PHY	O

5.4.8 GPADC

Table 5-42 GPADC Signal Description

Signal Name ^[1]	Description ^[2]	Type ^[3]
GPADC0	General Purpose ADC Input Channel 0/ BROM Boot Select	AI
GPADC1	General Purpose ADC Input Channel 1	AI
GPADC2	General Purpose ADC Input Channel 2	AI
GPADC3	General Purpose ADC Input Channel 3	AI
VCM-ADC	External Capacitor Connection	A I/O
VREFP-ADC	GPADC Reference Voltage (Positive)	P

Signal Name ^[1]	Description ^[2]	Type ^[3]
VREFN-ADC	GPADC Reference Voltage (Negative)	P

5.4.9 I2S/PCM

Table 5-43 I2S/PCM Signal Description

Signal Name ^[1]	Description ^[2]	Type ^[3]
I2S0-DOUT[3:0]	I2S0/PCM0 Serial Data Output Channel [3:0]	O
I2S0-DIN[3:0]	I2S0/PCM0 Serial Data Input Channel [3:0]	I
I2S0-MCLK	I2S0 Master Clock	O
I2S0-LRCK	I2S0/PCM0 Sample Rate Clock/Sync	I/O
I2S0-BCLK	I2S0/PCM0 Bit Rate Clock	I/O
I2S1-DOUT[1:0]	I2S1/PCM1 Serial Data Output Channel [1:0]	O
I2S1-DIN[1:0]	I2S1/PCM1 Serial Data Input Channel [1:0]	I
I2S1-MCLK	I2S1 Master Clock	O
I2S1-LRCK	I2S1/PCM01Sample Rate Clock/Sync	I/O
I2S1-BCLK	I2S1/PCM1 Bit Rate Clock	I/O
I2S2-DOUT[3:0]	I2S2/PCM2 Serial Data Output Channel [3:0]	O
I2S2-DIN[3:0]	I2S2/PCM2 Serial Data Input Channel [3:0]	I
I2S2-MCLK	I2S2 Master Clock	O
I2S2-LRCK	I2S2/PCM2 Sample Rate Clock/Sync	I/O
I2S2-BCLK	I2S2/PCM2 Bit Rate Clock	I/O
I2S3-DOUT[3:0]	I2S3/PCM3 Serial Data Output Channel [3:0]	O
I2S3-DIN[3:0]	I2S3/PCM3 Serial Data Input Channel [3:0]	I
I2S3-MCLK	I2S3 Master Clock	O
I2S3-LRCK	I2S3/PCM3 Sample Rate Clock/Sync	I/O
I2S3-BCLK	I2S3/PCM3 Bit Rate Clock	I/O
S-I2S0-DIN[1:0]	I2S0/PCM0 Serial Data Input Channel [1:0]	I
S-I2S0-DOUT[1:0]	I2S0/PCM0 Serial Data Output Channel [1:0]	O
S-I2S0-MCLK	I2S0 Master Clock	O
S-I2S0-LRCK	I2S0/PCM0 Sample Rate Clock/Sync	I/O
S-I2S0-BCLK	I2S0/PCM0 Bit Rate Clock	I/O

5.4.10 JTAG

Table 5-44 JTAG Signal Description

Signal Name ^[1]	Description ^[2]	Type ^[3]
JTAG-MS	ARM CPU JTAG Mode Selection	I
JTAG-CK	ARM CPU JTAG Clock Signal	I
JTAG-DO	ARM CPU JTAG Data Output	O
JTAG-DI	ARM CPU JTAG Data Input	I
S-JTAG-MS	CPUS JTAG Mode Selection	I
S-JTAG-CK	CPUS JTAG Clock Signal	I
S-JTAG-DO	CPUS JTAG Data Output	O
S-JTAG-DI	CPUS JTAG Data Input	I
S-RJTAG-MS	RISC-V JTAG Mode Select	I
S-RJTAG-CK	RISC-V JTAG Clock Signal	I
S-RJTAG-DO	RISC-V JTAG Data Output	O
S-RJTAG-DI	RISC-V JTAG Data Input	I

5.4.11 LEDC

Table 5-45 LEDC Signal Description

Signal Name ^[1]	Description ^[2]	Type ^[3]
LEDC	Intelligent Control LED Signal Output	O

5.4.12 LRADC

Table 5-46 LRADC Signal Description

Signal Name ^[1]	Description ^[2]	Type ^[3]
LRADC0	Low Rate ADC	AI
LRADC1	Low Rate ADC	AI

5.4.13 MIPI CSI

Table 5-47 MIPI CSI Signal Description

Signal Name ^[1]	Description ^[2]	Type ^[3]
MCSIA-D0P	MIPI CSI Controller A Data0 Positive Signal	AI
MCSIA-D0N	MIPI CSI Controller A Data0 Negative Signal	AI

Signal Name ^[1]	Description ^[2]	Type ^[3]
MCSIA-D1P	MIPI CSI Controller A Data1 Positive Signal	AI
MCSIA-D1N	MIPI CSI Controller A Data1 Negative Signal	AI
MCSIA-CKP	MIPI CSI Controller A Clock Positive Signal	AI
MCSIA-CKN	MIPI CSI Controller A Clock Negative Signal	AI
MCSI0-MCLK	Master Clock for MIPI Sensor	O
MCSIB-D0P	MIPI CSI Controller B Data0 Positive Signal	AI
MCSIB-D0N	MIPI CSI Controller B Data0 Negative Signal	AI
MCSIB-D1P	MIPI CSI Controller B Data1 Positive Signal	AI
MCSIB-D1N	MIPI CSI Controller B Data1 Negative Signal	AI
MCSIB-CKP	MIPI CSI Controller B Clock Positive Signal	AI
MCSIB-CKN	MIPI CSI Controller B Clock Negative Signal	AI
MCSI1-MCLK	Master Clock for MIPI Sensor	O
MCSIC-D0P	MIPI CSI Controller C Data0 Positive Signal	AI
MCSIC-D0N	MIPI CSI Controller C Data0 Negative Signal	AI
MCSIC-D1P	MIPI CSI Controller C Data1 Positive Signal	AI
MCSIC-D1N	MIPI CSI Controller C Data1 Negative Signal	AI
MCSIC-CKP	MIPI CSI Controller C Clock Positive Signal	AI
MCSIC-CKN	MIPI CSI Controller C Clock Negative Signal	AI
MCSI2-MCLK	Master Clock for MIPI Sensor	O
MCSID-D0P	MIPI CSI Controller D Data0 Positive Signal	AI
MCSID-D0N	MIPI CSI Controller D Data0 Negative Signal	AI
MCSID-D1P	MIPI CSI Controller D Data1 Positive Signal	AI
MCSID-D1N	MIPI CSI Controller D Data1 Negative Signal	AI
MCSID-CKP	MIPI CSI Controller D Clock Positive Signal	AI
MCSID-CKN	MIPI CSI Controller D Clock Negative Signal	AI
MCSI3-MCLK	Master Clock for MIPI Sensor	O
CSI-SM-HS	MIPI CSI Slave Mode Horizontal SYNC	O
CSI-SM-VS	MIPI CSI Slave Mode Vertical SYNC	O

5.4.14 MIPI DSI

Table 5-48 MIPI DSI Signal Description

Signal Name ^[1]	Description ^[2]	Type ^[3]
----------------------------	----------------------------	---------------------

Signal Name ^[1]	Description ^[2]	Type ^[3]
DSI0-D0P	DSI0 Differential Data0 Positive Signal	I/O
DSI0-D0N	DSI0 Differential Data0 Negative Signal	I/O
DSI0-D1P	DSI0 Differential Data1 Positive Signal	O
DSI0-D1N	DSI0 Differential Data1 Negative Signal	O
DSI0-D2P	DSI0 Differential Data2 Positive Signal	O
DSI0-D2N	DSI0 Differential Data2 Negative Signal	O
DSI0-D3P	DSI0 Differential Data3 Positive Signal	O
DSI0-D3N	DSI0 Differential Data3 Negative Signal	O
DSI0-CKP	DSI0 Differential Clock Positive Signal	O
DSI0-CKN	DSI0 Differential Clock Negative Signal	O
DSI1-D0P	DSI1 Differential Data0 Positive Signal	I/O
DSI1-D0N	DSI1 Differential Data0 Negative Signal	I/O
DSI1-D1P	DSI1 Differential Data1 Positive Signal	O
DSI1-D1N	DSI1 Differential Data1 Negative Signal	O
DSI1-D2P	DSI1 Differential Data2 Positive Signal	O
DSI1-D2N	DSI1 Differential Data2 Negative Signal	O
DSI1-D3P	DSI1 Differential Data3 Positive Signal	O
DSI1-D3N	DSI1 Differential Data3 Negative Signal	O
DSI1-CKP	DSI1 Differential Clock Positive Signal	O
DSI1-CKN	DSI1 Differential Clock Negative Signal	O

5.4.15 RAW NAND Flash

Table 5-49 RAW NAND Flash Signal Description

Signal Name ^[1]	Description ^[2]	Type ^[3]
NAND-WE	Nand Flash Write Enable	O
NAND-ALE	Nand Flash Address Latch Enable	O
NAND-CLE	Nand Flash Command latch Enable	O
NAND-CE[1:0]	Nand Flash Chip Select	O
NAND-RE	Nand Flash Read Enable	O
NAND-RB[1:0]	Nand Flash Ready/Busy Status Indicator Signal	I
NAND-DQ[7:0]	Nand Flash Data Bit	I/O
NAND-DQS	Nand Flash Data Strobe	I/O

5.4.16 OWA

Table 5-50 OWA Signal Description

Signal Name ^[1]	Description ^[2]	Type ^[3]
OWA-IN	One Wire Audio Input	I
OWA-OUT	One Wire Audio Output	O

5.4.17 Parallel CSI

Table 5-51 Parallel CSI Signal Description

Signal Name ^[1]	Description ^[2]	Type ^[3]
NCSI-PCLK	Parallel CSI Pixel Clock	I
NCSI-MCLK	Parallel CSI Master Clock	O
NCSI-HSYNC	Parallel CSI Horizontal Synchronous	I
NCSI-VSYNC	Parallel CSI Vertical Synchronous	I
NCSI-D[15:0]	Parallel CSI Data Bit	I

5.4.18 PCIe2.1&USB3.1 DRD

Table 5-52 PCIe2.1&USB3.1 DRD Signal Description

Signal Name ^[1]	Description ^[2]	Type ^[3]
USB2-DP	USB2.0 Data Signal DP	A I/O
USB2-DM	USB2.0 Data Signal DM	A I/O
USB2-REXT	USB2.0 External Reference Resistor	AO
PCIE-REF-CLKP	PCIe2.1 Differential Signal REFCLK (Positive)	A I/O
PCIE-REF-CLKN	PCIe2.1 Differential Signal REFCLK (Negative)	A I/O
PCIE-REXT	PCIe2.1 External Reference Resistor	AO
PCIE-RX0-DP/USB3-RXP	PCIe2.1 Differential Signal of RX (Positive)/USB3.1 SuperSpeed Differential Signal of RX (Positive)	AI
PCIE-RX0-DN/USB3-RXN	PCIe2.1 Differential Signal of RX (Negative)/USB3.1 SuperSpeed Differential Signal of RX (Negative)	AI
PCIE-TX0-DN/USB3-TXN	PCIe2.1 Differential Signal of TX (Negative)/USB3.1 SuperSpeed Differential Signal of TX (Negative)	AO
PCIE-TX0-DP/USB3-TXP	PCIe2.1 Differential Signal of TX (Positive)/USB3.1 SuperSpeed Differential Signal of TX (Positive)	AO
PCIE0-PERSTN	PCIe2.1 Warm Reset	O

Signal Name ^[1]	Description ^[2]	Type ^[3]
PCIE0-WAKEN	PCIe2.1 Wake Up	I
PCIE0-CLKREQN	PCIe2.1 Clock Request from PCIe Peripheral	I
VCC33-USB-2	3.3 V Power Supply for USB2.0 PHY	P
VCC33-18-USB-2	3.3 V Power Supply for USB2.0 PHY	P
VCC18-PCIE	1.8 V Power Supply for PCIe2.1	P
VDD09-PCIE	0.9 V Power Supply for PCIe2.1	P

5.4.19 PWM

Table 5-53 PWM Signal Description

Signal Name ^[1]	Description ^[2]	Type ^[3]
PWM[19:0]	Pulse Width Modulation Output Channel [19:0]	I/O
S-PWM[9:0]	Pulse Width Modulation Output Channel [9:0]	I/O

5.4.20 RTC&PLL

Table 5-54 RTC&PLL Signal Description

Signal Name ^[1]	Description ^[2]	Type ^[3]
X32KFOUT	32.768 kHz clock Fanout Provides low frequency clock for external devices	AO,OD
X32KIN	Clock Input of 32.768 kHz Crystal	AI
X32KOUT	Clock Output of 32.768 kHz Crystal	AO
PLLTEST	PLL Test Signal	AO, OD
VCC-RTC	RTC Power	P
VCC-PLL	Power Supply for System PLL	P

5.4.21 SDRAM

Table 5-55 SDRAM Signal Description

Signal Name ^[1]	Description ^[2]	Type ^[3]
SA[17:0]	DRAM Address Signal to the Memory Device	O
SACT	DRAM Activation Command Output	O
SBA[1:0]	DRAM Bank Address Signal to the Memory Device	O
SBG[1:0]	DRAM Bank Group Address Signal to the Memory Device	O
SCKE	DRAM Clock Enable Signal to the Memory Device	O

Signal Name ^[1]	Description ^[2]	Type ^[3]
SCKN	DRAM Active-Low Clock Signal to the Memory Device	O
SCKP	DRAM Active-High Clock Signal to the Memory Device	O
SCS[1:0]	DRAM Chip Select Signal to the Memory Device	O
SDQ[31:0]	DRAM Bidirectional Data Line to the Memory Device	I/O
SDQM[3:0]	DRAM Data Mask Signal to the Memory Device	I/O
SDQS[3:0]P	DRAM Active-High Bidirectional Data Strobes to the Memory Device	I/O
SDQS[3:0]N	DRAM Active-Low Bidirectional Data Strobes to the Memory Device	I/O
SODT[1:0]	DRAM On-Die Termination Output Signal	O
SRST	DRAM Reset Signal to the Memory Device	O
SZQ	DRAM ZQ Calibration(the signal connects to an external reference resistor which is used to calibrate DRAM input/output buffer)	AI
VCC-DRAM	Power Supply for DRAM IO	P
VCC-DRAML	Power Supply for DRAM IO	P
VDD18-DRAM	DRAM 1.8V Internal PAD Power	P

5.4.22 SPI&SPI_DBI

Table 5-56 SPI&SPI_DBI Signal Description

Signal Name ^[1]	Description ^[2]	Type ^[3]
SPI0-CS[1:0]	SPI0 Chip Select Signal, Low Active	I/O
SPI0-CLK	SPI0 Clock Signal Provides serial interface timing.	I/O
SPI0-MOSI	SPI0 Master Data Out, Slave Data In	I/O
SPI0-MISO	SPI0 Master Data In, Slave Data Out	I/O
SPI0-WP	SPI0 Write Protect, Low Active Protects the memory area against all program or erase instructions. It also can be used for serial data input and output for SPI Quad Input or Quad Output mode.	I/O
SPI0-HOLD	SPI0 Hold Signal Pauses any serial communication with the device without	I/O

Signal Name ^[1]	Description ^[2]	Type ^[3]
	deselecting or resetting it. It also can be used for serial data input and output for SPI Quad Input or Quad Output mode.	
SPI1-CS0	SPI1 Chip Select Signal, Low Active	I/O
SPI1-CLK	SPI1 Clock Signal Provides serial interface timing.	I/O
SPI1-MOSI	SPI1 Master Data Out, Slave Data In	I/O
SPI1-MISO	SPI1 Master Data In, Slave Data Out	I/O
SPI1-WP	SPI1 Write Protect, Low Active Protects the memory area against all program or erase instructions. It also can be used for serial data input and output for SPI Quad Input or Quad Output mode.	I/O
SPI1-HOLD	SPI1 Hold Signal Pauses any serial communication with the device without deselecting or resetting it. It also can be used for serial data input and output for SPI Quad Input or Quad Output mode.	I/O
SPI2-CS0	SPI2 Chip Select Signal, Low Active	I/O
SPI2-CLK	SPI2 Clock Signal Provides serial interface timing.	I/O
SPI2-MOSI	SPI2 Master Data Out, Slave Data In	I/O
SPI2-MISO	SPI2 Master Data In, Slave Data Out	I/O
DBI-CSX	Chip Select Signal, Low Active	I/O
DBI-SCLK	Serial Clock Signal	I/O
DBI-SDO	Data Output Signal	I/O
DBI-SDI	Data Input Signal The data is sampled on the rising edge and the falling edge	I/O
DBI-TE	Tearing Effect Input It is used to capture the external TE signal edge. The rising and falling edge is configurable.	I/O
DBI-DCX	DCX pin is the select output signal of data and command. DCX = 0: register command;	I/O

Signal Name ^[1]	Description ^[2]	Type ^[3]
	DCX = 1: data or parameter.	
DBI-WRX	When DBI operates in dual data lane format, the RGB666 format 2 can use WRX to transfer data	I/O
S-SPI0-CS0	S-SPI Chip Select Signal, Low Active	I/O
S-SPI0-CLK	S-SPI Clock Signal Provides serial interface timing.	I/O
S-SPI0-MOSI	S-SPI Master Data Out, Slave Data In	I/O
S-SPI0-MISO	S-SPI Master Data In, Slave Data Out	I/O

5.4.23 SPIFC

Table 5-57 SPIFC Signal Description

Signal Name	Description	Type
SPIF-CS0	SPI Peripheral Chip Select Signal, Low Active	I/O
SPIF-CLK	SPI Master Mode Clock Output	I/O
SPIF-MOSI	SPI Master Data Out, Slave Data In	I/O
SPIF-MISO	SPI Master Data In, Slave Data Out	I/O
SPIF-DQS	Data Strobe Signal	I
SPIF-D[7:4]	SPI Master Mode Data in Octal Mode.	I/O
SPIF-WP	SPI Write Protect, Low Active	I/O
SPIF-HOLD	SPI Hold Signal	I/O

5.4.24 SMHC

Table 5-58 SMHC Signal Description

Signal Name ^[1]	Description ^[2]	Type ^[3]
SDC0-CMD	Command Signal for SD Card	I/O, OD
SDC0-CLK	Clock for SD Card	O
SDC0-D[3:0]	Data Input and Output for SD Card	I/O
SDC1-CMD	Command Signal for SDIO WIFI	I/O, OD
SDC1-CLK	Clock for SDIO WIFI	O
SDC1-D[3:0]	Data Input and Output for SDIO WIFI	I/O
SDC2-CMD	Command Signal for eMMC	I/O, OD
SDC2-CLK	Clock for eMMC	O

Signal Name ^[1]	Description ^[2]	Type ^[3]
SDC2-D[8:0]	Data Input and Output for eMMC	I/O
SDC2-RST	Reset for eMMC	O
SDC2-DS	Clock input for eMMC	I

5.4.25 System

Table 5-59 System Signal Description

Signal Name ^[1]	Description ^[2]	Type ^[3]
FEL	<p>Boot Select</p> <p>Jump to the Try Media Boot process when FEL is high level, or else enter into the mandatory upgrade process.</p> <p>For more details, see section 2.4 BROM System in the <i>A523_User_Manual</i>.</p>	I
JTAG-SEL	<p>JTAG mode select</p> <p>The signal is used to select the port from which JTAG function outputs.</p>	I
NMI	Non-Maskable Interrupt	I/O, OD
RESET	Reset Signal (Low Active)	I/O, OD

5.4.26 TCONLCD

Table 5-60 TCONLCD Signal Description

Signal Name ^[1]	Description ^[2]	Type ^[3]
LCD0-D[23:0]	LCD Data Input/Output	I/O
LCD0-CLK	<p>LCD Clock</p> <p>The pixel data are synchronized by this clock</p>	O
LCD0-VSYNC	<p>LCD Vertical Sync</p> <p>It indicates one new frame</p>	O
LCD0-HSYNC	<p>LCD Horizontal Sync</p> <p>It indicates one new scan line</p>	O
LCD0-DE	LCD Data Output Enable	O
LCD0-TRIG	<p>LCD0 Sync</p> <p>It is input from peripherals for sync</p>	I
LCD1-TRIG	LCD1 Sync	I

Signal Name ^[1]	Description ^[2]	Type ^[3]
	It is input from peripherals for sync	
LVDS0-D[3:0]P	LVDS0 Positive Port of Data Channel [3:0]	AO
LVDS0-D[3:0]N	LVDS0 Negative Port of Data Channel [3:0]	AO
LVDS0-CKP	LVDS0 Positive Port of Clock	AO
LVDS0-CKN	LVDS0 Negative Port of Clock	AO
LVDS1-D[3:0]P	LVDS1 Positive Port of Data Channel [3:0]	AO
LVDS1-D[3:0]N	LVDS1 Negative Port of Data Channel [3:0]	AO
LVDS1-CKP	LVDS1 Positive Port of Clock	AO
LVDS1-CKN	LVDS1 Negative Port of Clock	AO

5.4.27 TWI

Table 5-61 TWI Signal Description

Signal Name ^[1]	Description ^[2]	Type ^[3]
TWI0-SCK	TWI0 Serial Clock Signal	I/O
TWI0-SDA	TWI0 Serial Data Signal	I/O
TWI1-SCK	TWI1 Serial Clock Signal	I/O
TWI1-SDA	TWI1 Serial Data Signal	I/O
TWI2-SCK	TWI2 Serial Clock Signal	I/O
TWI2-SDA	TWI2 Serial Data Signal	I/O
TWI3-SCK	TWI3 Serial Clock Signal	I/O
TWI3-SDA	TWI3 Serial Data Signal	I/O
TWI4-SCK	TWI4 Serial Clock Signal	I/O
TWI4-SDA	TWI4 Serial Data Signal	I/O
TWI5-SCK	TWI5 Serial Clock Signal	I/O
TWI5-SDA	TWI5 Serial Data Signal	I/O
S-TWI0-SCK	S-TWI0 Serial Clock Signal	I/O
S-TWI0-SDA	S-TWI0 Serial Data Signal	I/O
S-TWI1-SCK	S-TWI1 Serial Clock Signal	I/O
S-TWI1-SDA	S-TWI1 Serial Data Signal	I/O
S-TWI2-SCK	S-TWI1 Serial Clock Signal	I/O
S-TWI2-SDA	S-TWI1 Serial Data Signal	I/O

5.4.28 USB2.0 DRD

Table 5-62 USB2.0 DRD Signal Description

Signal Name ^[1]	Description ^[2]	Type ^[3]
USB0-DP	USB2.0 Data Signal DP	A I/O
USB0-DM	USB2.0 Data Signal DM	A I/O
USB0-REXT	USB2.0 External Reference Resistor	AO
VCC33-USB	3.3 V Analog Power Supply for USB2.0 DRD and USB2.0 Host	P
VCC33-18-USB	3.3 V Analog Power Supply for USB2.0 DRD and USB2.0 Host	P
VDD09-USB	0.9 V USB Digital Power Supply	p

5.4.29 USB2.0 Host

Table 5-63 USB2.0 Host Signal Description

Signal Name ^[1]	Description ^[2]	Type ^[3]
USB1-DP	USB2.0 Data Signal DP	A I/O
USB1-DM	USB2.0 Data Signal DM	A I/O
USB1-REXT	USB2.0 External Reference Resistor AO	AO

5.4.30 UART

Table 5-64 UART Signal Description

Signal Name ^[1]	Description ^[2]	Type ^[3]
UART0-TX	UART0 Data Transmitter	O
UART0-RX	UART0 Data Receiver	I
UART1-TX	UART1 Data Transmitter	O
UART1-RX	UART1 Data Receiver	I
UART1-CTS	UART1 Data Clear to Send	I
UART1-RTS	UART1 Data Request to Send	O
UART2-TX	UART2 Data Transmitter	O
UART2-RX	UART2 Data Receiver	I
UART2-CTS	UART2 Data Clear to Send	I
UART2-RTS	UART2 Data Request to Send	O
UART3-TX	UART3 Data Transmitter	O
UART3-RX	UART3 Data Receiver	I
UART3-CTS	UART3 Data Clear to Send	I

Signal Name ^[1]	Description ^[2]	Type ^[3]
UART3-RTS	UART3 Data Request to Send	O
UART4-TX	UART4 Data Transmitter	O
UART4-RX	UART4 Data Receiver	I
UART4-CTS	UART4 Data Clear to Send	I
UART4-RTS	UART4 Data Request to Send	O
UART5-TX	UART5 Data Transmitter	O
UART5-RX	UART5 Data Receiver	I
UART5-CTS	UART5 Data Clear to Send	I
UART5-RTS	UART5 Data Request to Send	O
UART6-TX	UART6 Data Transmitter	O
UART6-RX	UART6 Data Receiver	I
UART6-CTS	UART6 Data Clear to Send	I
UART6-RTS	UART6 Data Request to Send	O
UART7-TX	UART7 Data Transmitter	O
UART7-RX	UART7 Data Receiver	I
UART7-CTS	UART7 Data Clear to Send	I
UART7-RTS	UART7 Data Request to Send	O
S-UART0-TX	S-UART0 Data Transmitter	O
S-UART0-RX	S-UART0 Data Receiver	I
S-UART1-TX	S-UART1 Data Transmitter	O
S-UART1-RX	S-UART1 Data Receiver	I

6 Electrical characteristics

6.1 Parameter Conditions

6.1.1 Minimum and Maximum Values

Unless otherwise specified the minimum and maximum values are guaranteed in the worst conditions of ambient temperature, supply voltage, and frequencies by tests in production on 100% of the devices with ambient temperature at $T_a = 25\text{ }^\circ\text{C}$ and $T_a = T_a \text{ max}$.

Data based on characterization results, design simulation, and/or technology characteristics are indicated in the table footnotes and are not tested in production.

6.1.2 Typical Values

Unless otherwise specified, the typical data are based on $T_a = 25\text{ }^\circ\text{C}$. They are given only as design guidelines.

6.1.3 Temperature Definitions

- Ambient Temperature— the temperature of the surrounding environment.
- Junction Temperature— the hottest temperature of the silicon chip inside the package.
- Absolute Maximum Junction Temperature— the temperature beyond which damage occurs to the device. The device may not function or meet expected performance at this temperature.
- Recommended Operating Temperature— the junction temperature at which the device operates continuously at the designated performance over the designed lifetime. The reliability of the device may be degraded if the device operates above this temperature. Some devices will not function electrically above this temperature.

6.2 Absolute Maximum Ratings

Absolute Maximum Ratings are those values beyond which damage to the device may occur. The following table specifies the absolute maximum ratings.



Stresses beyond those listed under Table 6-1 may affect reliability or cause permanent damage to the device. These are stress ratings only. Functional operation of the device at these or any other conditions beyond those indicated under section 6.3 Recommended Operating

Conditions is not implied. Exposure to absolute maximum rated conditions for extended periods may affect device reliability.

Table 6-1 Absolute Maximum Ratings

Symbol	Parameter	Min ⁽¹⁾	Max ⁽¹⁾	Unit
AVCC	Power Supply for Analog Part	-0.3	2.16	V
CPVIN	Analog power for LDO	-0.3	2.16	V
VCC-DRAM	Power Supply for DRAM IO	-0.3	1.8	V
VCC-DRAML	Power Supply for DRAM IO	-0.3	1.8	V
VCC-DCXO	Digital Compensated Crystal Oscillator Power Supply	-0.3	2.16	V
VCC-EFUSE	Power Supply for eFuse	-0.3	2.16	V
VCC-LVDS0	Analog Power Supply for LVDS0/1 and DSI0/1	-0.3	2.16	V
VCC-MCSI	Power supply for MIPI CSI	-0.3	2.16	V
VCC-IO	Power Supply for 3.3 V Digital Part	-0.3	3.96	V
VCC-PC	Digital Port C Power	-0.3	3.96	V
VCC-PD	Digital Port D Power	-0.3	3.96	V
VCC-PE	Digital Port E Power	-0.3	3.96	V
VCC-PG	Digital Port G Power	-0.3	3.96	V
VCC-PK	Digital Port K Power	-0.3	3.96	V
VCC-PL	Digital Port L Power	-0.3	3.96	V
VCC-PM	Digital Port M Power	-0.3	3.96	V
VCC-PLL	Power Supply for System PLL	-0.3	2.16	V
VCC-RTC	RTC Power	-0.3	2.16	V
VCC18-PCIE	1.8 V Power Supply for PCIe2.1	-0.3	2.16	V
VCC33-18-USB	3.3 V Analog Power Supply for USB2.0 DRD and USB2.0 Host	-0.3	3.96	V
VCC33-18-USB-2	3.3 V Power Supply for USB2.0 PHY	-0.3	3.96	V
VCC18-EDP	1.8V Analog Supply	-0.3	2.16	V
VCC33-USB	3.3 V Analog Power Supply for USB2.0 DRD and USB2.0 Host	-0.3	3.96	V
VCC33-USB-2	3.3 V Power Supply for USB2.0 PHY	-0.3	3.96	V
VDD-CPUB	Power Supply for Big Cores of ARM CPU	-0.3	1.2	V
VDD-CPUL	Power Supply for Little Cores of ARM CPU	-0.3	1.2	V
VDD-CPUS	Power Supply for CPUS	-0.3	1.2	V

Symbol	Parameter		Min ⁽¹⁾	Max ⁽¹⁾	Unit
VDD-DNR	Power Supply for RISC-V		-0.3	1.2	V
VDD-GPU	Power Supply for GPU		-0.3	1.2	V
VDD-SYS	Power Supply for System		-0.3	1.2	V
VDD-VE	Power Supply for VE		-0.3	1.2	V
VDD09-EDP	0.9V Digital Supply		-0.3	1.2	V
VDD09-PCIE	0.9 V Power Supply for PCIe2.1		-0.3	1.2	V
VDD09-USB	0.9 V USB Digital Power Supply		-0.3	1.2	V
VDD18-DRAM	DRAM 1.8V Internal PAD Power		-0.3	2.16	V
VDD33	Power Supply for 3.3V Analog Part		-0.3	3.96	V
V _{ESD}	Electrostatic	Human Body Model (HBM) ⁽³⁾	-2000	2000	V
	Discharge ⁽²⁾	Charged Device Model (CDM) ⁽⁴⁾	-250	250	V
I _{Latch-up}	Latch-up I-test performance current-pulse injection on each IO pin ⁽⁵⁾		Pass		
	Latch-up over-voltage performance voltage injection on each IO pin ⁽⁶⁾		Pass		

- (1) The min/max voltages of power rails are guaranteed by design, not tested in production.
- (2) Electrostatic discharge (ESD) to measure device sensitivity/immunity to damage caused by electrostatic discharges into the devices.
- (3) Level listed above is the passing level per ESDA/JEDEC JS-001-2017.
- (4) Level listed above is the passing level per ESDA/JEDEC JS-002-2018.
- (5) Based on JESD78E; each device is tested with IO pin injection of ±200 mA at room temperature.
- (6) Based on JESD78E; each device is tested with a stress voltage of 1.5 x Vddmax at room temperature.

6.3 Recommended Operating Conditions

the following table describes operating conditions of the A523.

NOTE

Logic functions and parameter values are not assured out of the range specified in the recommended operating conditions.

Table 6-2 Recommended Operating Conditions

Symbol	Parameter	Min	Typ	Max	Unit
--------	-----------	-----	-----	-----	------

Symbol	Parameter	Min	Typ	Max	Unit
AVCC	Power Supply for Analog Part	1.782	1.8	1.818	V
CPVIN	Analog power for LDO	1.746	1.8	1.854	V
VCC-DCXO	Digital Compensated Crystal Oscillator Power Supply	1.782	1.8	1.818	V
VCC-DRAM	Power Supply for DDR3	1.425	1.5	1.575	V
	Power Supply for DDR3L	1.283	1.35	1.45	
	Power Supply for LPDDR3	1.14	1.2	1.30	
	Power Supply for DDR4	1.14	1.2	1.26	
	Power Supply for LPDDR4 and LPDDR4x	1.06	1.1	1.17	
VCC-DRAML	Power Supply for DRAM IO	0.57	0.6 ⁽¹⁾	0.65	V
VCC-EFUSE	Power Supply for eFuse	1.62	1.8	1.98	V
VCC-IO	Power Supply for 3.3 V Digital Part	2.97	3.3	3.63	V
VCC-LVDS0	Analog Power Supply for LVDS0/1 and DSI0/1	1.71	1.8	1.89	V
VCC-MCSI	Power supply for MIPI CSI	1.71	1.8	1.89	V
VCC-PC	Digital Port C Power	1.62	1.8	1.98	V
	1.8 V voltage 3.3 V voltage	2.97	3.3	3.63	
VCC-PD	Digital Port D Power	1.62	1.8	1.98	V
	1.8 V voltage 3.3 V voltage	2.97	3.3	3.63	
VCC-PE	Digital Port E Power	1.62	1.8	1.98	V
	1.8 V voltage 3.3 V voltage	2.97	3.3 ⁽²⁾	3.63	
VCC-PG	Digital Port G Power	1.62	1.8	1.98	V
	1.8 V voltage 3.3 V voltage	2.97	3.3	3.63	
VCC-PK	Digital Port K Power	1.62	1.8	1.98	V
	1.8 V voltage 3.3 V voltage	2.97	3.3	3.63	
VCC-PL	Digital Port L Power	1.62	1.8	1.98	V
	1.8 V voltage 3.3 V voltage	2.97	3.3	3.63	

Symbol	Parameter	Min	Typ	Max	Unit
VCC-PM	Digital Port M Power	1.62	1.8	1.98	V
	1.8 V voltage	2.97	3.3	3.63	
	3.3 V voltage				
VCC-PLL	Power Supply for System PLL	1.62	1.8	1.98	V
VCC-RTC	RTC Power	1.62	1.8	1.98	V
VCC18-PCIE	1.8 V Power Supply for PCIe2.1	1.71	1.8	1.89	V
VCC18-EDP	1.8V Analog Supply	1.71	1.8	1.89	V
VCC33-18-USB	3.3 V Analog Power Supply for USB2.0 DRD and USB2.0 Host	3.07	3.3	3.63	V
VCC33-18-USB-2	3.3 V Power Supply for USB2.0 PHY	3.07	3.3	3.63	V
VCC33-USB	3.3 V Analog Power Supply for USB2.0 DRD and USB2.0 Host	3.07	3.3	3.63	V
VCC33-USB-2	3.3 V Power Supply for USB2.0 PHY	3.07	3.3	3.63	V
VDD-CPUB	Power Supply for Big Cores of ARM CPU	0.9	-	1.2	V
VDD-CPUL	Power Supply for Little Cores of ARM CPU	0.9	-	1.2	V
VDD-CPUS	Power Supply for CPUS	0.9	-	0.99	V
VDD-DNR	Power Supply for RISC-V	0.9	-	0.99	V
VDD-GPU	Power Supply for GPU	0.9	-	0.99	V
VDD-SYS	Power Supply for System	0.9	-	0.99	V
VDD-VE	Power Supply for VE	0.9	-	0.99	V
VDD09-EDP	0.9V Digital Supply	0.9	-	0.99	V
VDD09-PCIE	0.9 V Power Supply for PCIe2.1	0.9	-	0.99	V
VDD09-USB	0.9 V USB Digital Power Supply	0.9	-	0.99	V
VDD18-DRAM	DRAM 1.8V Internal PAD Power	1.71	1.8	1.89	V
VDD33	Power Supply for 3.3V Analog Part	2.97	3.3	3.63	V

- (1) VCC-DRAML is 0.6 V only when LPDDR4x is used. When DDR3/DDR3L/LPDDR3/DDR4/LPDDR4 is selected, the voltage of VCC-DRAM and VCC-DRAML are the same.
- (2) VCC-PE is compatible with 2.8 V typical voltage and the recommended operating range is from 2.7 V to 3.63 V.

6.4 DC Electrical Characteristics

Table 6-3 summarizes the DC electrical characteristics of the A523. For the interfaces of GPIO function port, refer to the DC parameters in Table 6-3 unless otherwise stated.

Table 6-3 DC Electrical Characteristics⁽¹⁾

(VCC-IO/VCC-PC/VCC-PD/VCC-PE/VCC-PG/VCC-PK/VCC-PL/VCC-PM)

Symbol	Parameter	Min	Typ	Max	Unit	
V _{IH}	High-Level Input Voltage	0.7 * VCC-IO	-	VCC-IO + 0.3	V	
V _{IL}	Low-Level Input Voltage	-0.3	-	0.3 * VCC-IO	V	
R _{PU}	Input Pull-up Resistance	PL0, PL1	2.82	4.7	6.58	kΩ
		PC0, PC1, PC3, PC6, PC7, PF3, PF6, PG1 to PG5	9	15	21	kΩ
		Other GPIOs	60	100	140	kΩ
R _{PD}	Input Pull-down Resistance	PL0, PL1	2.82	4.7	6.58	kΩ
		PC0, PC1, PC3, PC6, PC7, PF3, PF6, PG1 to PG5	9	15	21	kΩ
		Other GPIOs	60	100	140	kΩ
I _{IH}	High-Level Input Current	-	-	10	uA	
I _{IL}	Low-Level Input Current	-	-	10	uA	
V _{OH}	High-Level Output Voltage	VCC-IO - 0.3	-	VCC-IO	V	
V _{OL}	Low-Level Output Voltage	0	-	0.2	V	
I _{OZ}	Tri-State Output Leakage Current	-10	-	10	uA	
C _{IN}	Input Capacitance	-	-	5	pF	
C _{OUT}	Output Capacitance	-	-	5	pF	

(1) Guaranteed by design.

All I/Os in A523 are CMOS. The following figure shows the input characteristics for standard I/Os.

Figure 6-1 Standard I/O Input Characteristics - CMOS port

CMOS standard requirement:

$$V_{IH}=0.6933V_{DD}$$

$$V_{IL}=0.4198V_{DD}$$

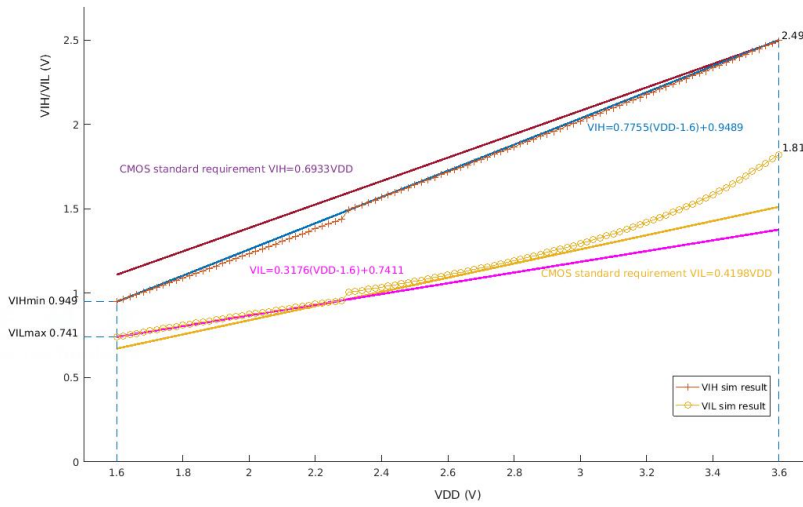

6.5 SMHC Electrical Characteristics

The SMHC electrical parameters are related to different supply voltage.

Figure 6-2 SMHC Voltage Waveform

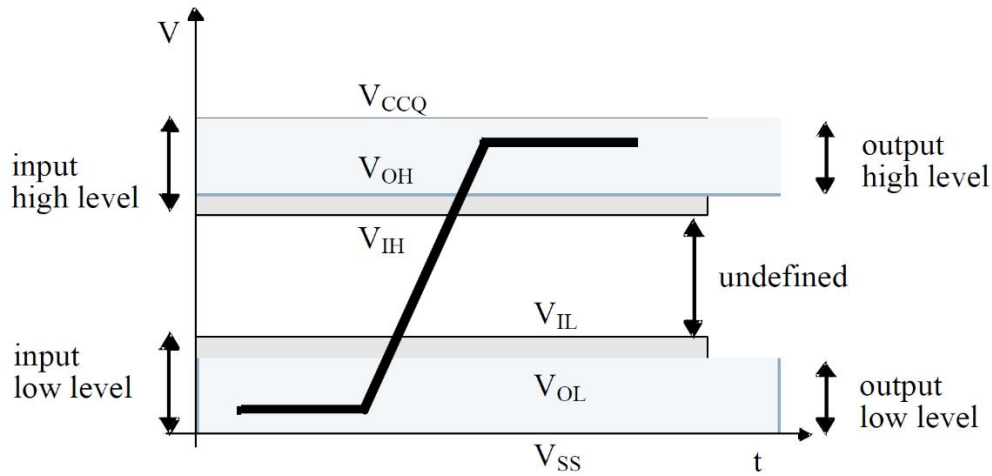

Table 6-4 shows 3.3 V SMHC electrical parameters.

Table 6-4 3.3 V SMHC Electrical Parameters

Symbol	Parameter	Min	Typ	Max	Unit
VDD	Power voltage	2.7	-	3.6	V
V _{CCQ}	I/O voltage	2.7	-	3.6	V
V _{OH}	Output high-level voltage	0.75 * V _{CCQ}	-	-	V
V _{OL}	Output low-level voltage	-	-	0.125 * V _{CCQ}	V
V _{IH}	Input high-level voltage	0.625 * V _{CCQ}	-	V _{CCQ} + 0.3	V

Symbol	Parameter	Min	Typ	Max	Unit
V _{IL}	Input low-level voltage	V _{SS} −0.3	-	0.25 * V _{CCQ}	V

Table 6-5 shows 1.8 V SMHC electrical parameters.

Table 6-5 1.8 V SMHC Electrical Parameters

Symbol	Parameter	Min	Typ	Max	Unit
VDD	Power voltage	2.7	-	3.6	V
V _{CCQ}	I/O voltage	1.7		1.95	V
V _{OH}	Output high-level voltage	V _{CCQ} −0.45	-	-	V
V _{OL}	Output low-level voltage	-	-	0.45	V
V _{IH}	Input high-level voltage	0.65 * V _{CCQ} ⁽¹⁾	-	V _{CCQ} + 0.3	V
V _{IL}	Input low-level voltage	V _{SS} −0.3	-	0.35 * V _{CCQ} ⁽²⁾	V

(1).0.7 * V_{CCQ} for MMC5.1 lower.
(2).0.3 * V_{CCQ} for MMC5.1 lower.

6.6 GPADC Electrical Characteristics

The GPADC contains a 4-ch analog-to-digital (ADC) converter. The GPADC is a type of successive approximation register (SAR) converter. Table 6-6 lists GPADC electrical characteristics.

Table 6-6 GPADC Electrical Characteristics

Parameter	Min	Typ	Max	Unit
ADC Resolution	-	12	-	bits
Full-scale Input Range	0	-	AVCC	V
Effective Precision	-	10	-	bits
Sampling Rate	-	-	1	MHz
Conversion Time	-	13	-	ADC Clock Cycles

6.7 LRADC Electrical Characteristics

The LRADC is 6-bit resolution ADC for key application. The LRADC can work up to 2 kHz conversion rate. Table 6-7 lists LRADC electrical characteristics.

Table 6-7 LRADC Electrical Characteristics

Parameter	Min	Typ	Max	Unit
ADC Resolution	-	6	-	bits

Parameter	Min	Typ	Max	Unit
Full-scale Input Range			LEVELB ⁽¹⁾	V
Effective Precision	-	5	-	bits
Sampling Rate	-	-	2	kHz
Conversion Time	-	6	-	ADC Clock Cycles

(1) The maximum value of LEVELB is 1.286 V. For details, see the register description of LRADC in *A523_User_Manual*.

6.8 Audio Codec Electrical Characteristics

Test Conditions

VDD-SYS = 0.9 V, AVCC = 1.8 V, Ta = 25 °C, 1 kHz sinusoid signal, DAC fs = 48 kHz, ADC fs = 16 kHz, input gain = 0 dB, 16-bit audio data unless otherwise stated.

Table 6-8 Audio Codec Typical Performance Parameters

Symbol	Parameter	Test Conditions	Min	Typ	Max	Unit
DAC Path	DAC to HPOUTL or HPOUTR(R=100K,CPVDD=1.2V)					
	Full-scale	0 dBFS 1 kHz	-	555	-	Vrms
	SNR(A-weighted)	0 data	-	100	-	dB
	THD+N	0 dBFS 1 kHz	-	-89	-	dB
	Crosstalk	R_0dB_L_0data 1kHz L_0dB_R_0data 1kHz	-	-94	-	dB
	DAC to HPOUTL or HPOUTR(R=16Ω,CPVDD=1.2V)					
	Full-scale	0dBFS 1 kHz	-	520	-	Vrms
	SNR(A-weighted)	0data	-	100	-	dB
	THD+N (16.5mW)	Full-scale Level	-	-25	-	dB
	THD+N(10mW)	1 kHz	-	-77	-	dB
	Crosstalk	R_0dB_L_0data 1 kHz L_0dB_R_0data 1 kHz	-	-94	-	dB
	DAC to HPOUTL or HPOUTR(R=32Ω, CPVDD=1.2V)					
	Full-scale	0 dBFS 1 kHz	-	540	-	Vrms
	SNR(A-weighted)	0 data	-	100	-	dB
	THD+N (9.0 mW)	0 dBFS 1 kHz	-	-83	-	dB
	Crosstalk	R_0dB_L_0data 1 kHz	-	-94	-	dB

Symbol	Parameter	Test Conditions	Min	Typ	Max	Unit
		L_0dB_R_0data 1 kHz				
	DAC to LINEOUTLP/N or LINEOUTRP/N(R=100K)					
	Full-scale	0 dBFS 1 kHz	-	1.08	-	Vrms
	SNR(A-weighted)	0data	-	103	-	dB
	THD+N	0 dBFS 1 kHz	-	-90	-	dB
	Crosstalk	R_0dB_L_0data 1 kHz L_0dB_R_0data 1 kHz	-	-110	-	dB
	MICIN via ADC					
ADC Path	Output Level	MICP=3.3Vpp/2, MICN=3.3Vpp/2, 1 kHz, 0 dB Gain	-	880	-	mFFS
	SNR(A-weighted)		-	95	-	dB
	THD+N		-	-84	-	dB
	Output Level	MICP=1.69Vpp/2, MICN=1.69Vpp/2, 1 kHz, 6 dB Gain	-	880	-	mFFS
	SNR(A-weighted)		-	93	-	dB
	THD+N		-	-87	-	dB
	Output Level	MICP=0.805Vpp/2, MICN=0.805Vpp/2, 1 kHz, 12 dB Gain	-	880	-	mFFS
	SNR(A-weighted)		-	93	-	dB
	THD+N		-	-82	-	dB
	Output Level	MICP=0.4035Vpp/2, MICN=0.4035Vpp/2, 1 kHz, 18 dB Gain	-	880	-	mFFS
	SNR(A-weighted)		-	91	-	dB
	THD+N		-	-83	-	dB
	Output Level	MICP=0.204Vpp/2, MICN=0.204Vpp/2, 1 kHz, 24 dB Gain	-	880	-	mFFS
	SNR(A-weighted)		-	89	-	dB
	THD+N		-	-82	-	dB
	Output Level	MICP=0.1032Vpp/2, MICN=0.1032Vpp/2, 1 kHz, 30 dB Gain	-	880	-	mFFS
	SNR(A-weighted)		-	86	-	dB
	THD+N		-	-79	-	dB
	Output Level	MICP=0.0524Vpp/2, MICN=0.0524Vpp/2, 1 kHz, 36 dB Gain	-	880	-	mFFS
	SNR(A-weighted)		-	80	-	dB
	THD+N		-	-76	-	dB

6.9 Clock Electrical Characteristics

6.9.1 Input Clock Requirements

6.9.1.1 High-speed Crystal/Ceramic Resonator Characteristics

The high-speed external clock can be supplied with a 24 MHz crystal resonator (oscillation mode). The 24 MHz crystal resonator provides 24 MHz reference clock which is connected to the DXIN and DXOUT terminals.

Table 6-9 High-speed 24 MHz Crystal Requirements

Symbol	Parameter	Min	Typ	Max	Unit
$f_{X24M-IN}$	Crystal parallel resonance frequency	-	24	-	MHz
	Crystal frequency stability and tolerance at 25 °C ⁽¹⁾	-50	-	+50	ppm
	Oscillation mode	Fundamental			-
C_0	Shunt capacitance ⁽²⁾	-	6.5	-	pF

1. The 50 ppm frequency stability and tolerance can meet the requirement of A523. We recommend selecting 20 ppm crystal devices. If the REFCLK-OUT (24 MHz fanout) is used for Wi-Fi chip, the crystal uses the recommended specification or the specified model for Wi-Fi chip.
2. The 6.5 pF is only a simulation value. The crystal shunt capacitance (C_0) is given by the crystal manufacturer.

Table 6-10 Crystal Circuit Parameters

Symbol	Parameter
C_1	C_1 capacitance
C_2	C_2 capacitance
C_L	Equivalent load capacitance, specified by the crystal manufacturer
C_0	Crystal shunt capacitance, specified by the crystal manufacturer
C_{shunt}	Total shunt capacitance

Frequency stability mainly requires that the total load capacitance (C_L) be constant. The crystal manufacturer typically specifies a total load capacitance which is the series combination of C_1 , C_2 , and C_{shunt} .

The total load capacitance is $C_L = [(C_1 * C_2)/(C_1 + C_2)] + C_{shunt}$.

- C_1 and C_2 represent the total capacitance of the respective PCB trace, load capacitor, and other components (excluding the crystal) connected to each crystal terminal. C_1 and C_2 are usually the same size.
- C_{shunt} is the crystal shunt capacitance (C_0) plus any mutual capacitance ($C_{pkg} + C_{PCB}$) seen across the DXIN and DXOUT signals.

In the application, the crystal resonator and the load capacitors must be placed close to the oscillator pins in order to minimize output distortion and the startup stabilization time. Refer to the crystal resonator manufacturer for more details on the resonator characteristics.

6.9.1.2 Low-speed Crystal/Ceramic Resonator Characteristics

The A523 contains an RC oscillation circuit that generates a 32.768 kHz clock, meanwhile, the DCXO module can calibrate the RC oscillation circuit regularly. If the product does not have a high requirement for the accuracy of the system clock, the external 32.768 kHz crystal circuit can be omitted and the internal RC oscillation circuit can be adopted, meanwhile, the relevant clock configuration needs to be turned on by the software.

The A523 also can connect to a 32.768 kHz crystal resonator (oscillation mode). The 32.768 kHz crystal resonator provides 32.768 kHz reference clock which is connected to the X32KIN and X32KOUT terminals. In the application, the crystal resonator and the load capacitors must be placed close to the oscillator pins to minimize output distortion and the startup stabilization time. Refer to the crystal resonator manufacturer for more details on the resonator characteristics.

Table 6-11 Low-speed 32.768 kHz Crystal Circuit Characteristics

Symbol	Parameter	Min	Typ	Max	Unit
$f_{X32K-IN}$	Crystal parallel resonance frequency	-	32.768	-	kHz
	Crystal frequency stability and tolerance at 25 °C ⁽¹⁾	-	-	-	ppm
	Oscillation mode	Fundamental			-
C_0	Shunt capacitance ⁽²⁾	-	1.1	-	pF

The A523 has no requirement for the frequency stability and tolerance of 32.768 kHz crystal. If the actual product has requirement for the accuracy of timing function, the 20 ppm stability and tolerance is recommended.

The 1.1 pF is only a simulation value. The crystal shunt capacitance (C_0) is given by the crystal manufacturer.

6.9.2 Output clock characteristics

6.9.2.1 24MHz Clock Fanout

The REFCLK-OUT signal can output 24MHz clock. The following table lists the output clock characteristics.

Table 6-12 REFCLK-OUT Output Clock Characteristics

Parameter	Specification	Unit
Input Source	24 MHz crystal	-
Nominal Output Frequency	24	MHz
Frequency Accuracy	The output frequency accuracy is related to the accuracy of external crystal.	ppm
Duty Cycle	50	%
Signal Type	Square-wave	-

6.9.2.2 32.768 kHz Clock Fanout

The X32KFOUT signal can output 32.768 kHz clock. The following table lists the output clock characteristics.

Table 6-13 X32KFOUT Output Clock Characteristics

Parameter	Specification	Unit
Input Source	24 MHz crystal or 32.768 kHz crystal	-
Nominal Output Frequency	32.768	kHz
Frequency Accuracy	The output frequency accuracy is related to the accuracy of external crystal.	ppm
Duty Cycle	50	%
Signal Type	Square-wave	-

6.10 Internal Reset Electrical Characteristics

Table 6-14 Internal Reset Electrical Characteristics

Parameter	Test Condition	Min	Typ	Max	Unit
Power-on threshold voltage of	Ta=-25°C to 75°C	-	700	-	mV

Parameter	Test Condition	Min	Typ	Max	Unit
VDD-SYS on which the reset signal is excited					
Reset active timeout period	Ta=-25°C to 75°C	-	32 ⁽¹⁾	-	ms

(1) This indicates the time required for A523 to complete reset.

6.11 Interface Timing

6.11.1 RAW NAND Interface Timing

Figure 6-3 Conventional Serial Access Cycle Timing (SAM0)

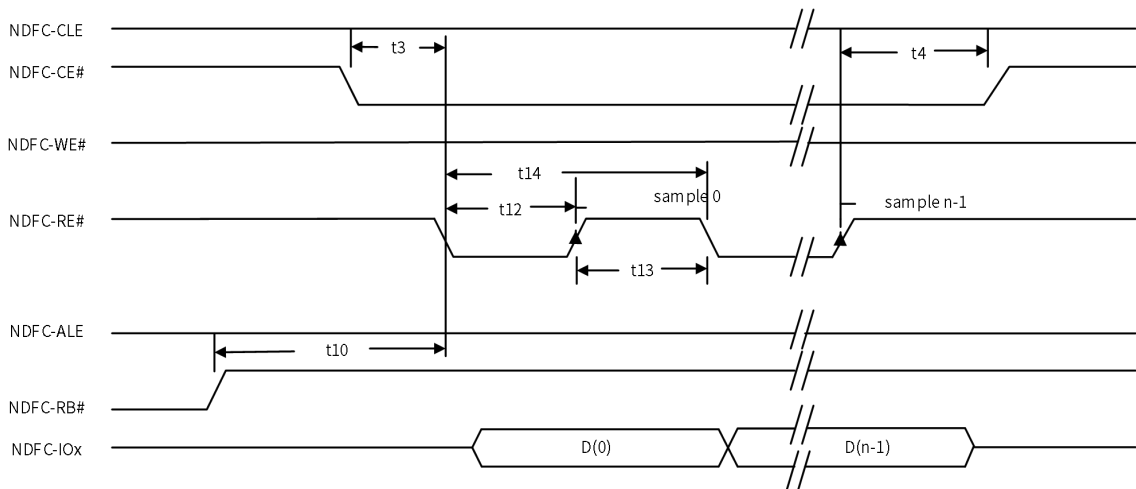

Figure 6-4 EDO Type Serial Access after Read Cycle Timing (SAM1)

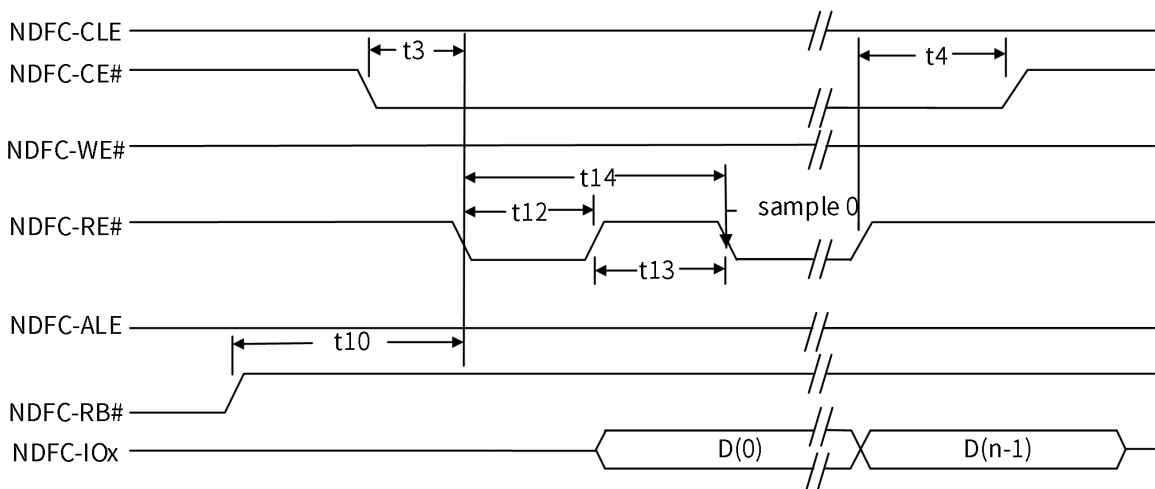

Figure 6-5 Extending EDO Type Serial Access Mode Timing (SAM2)

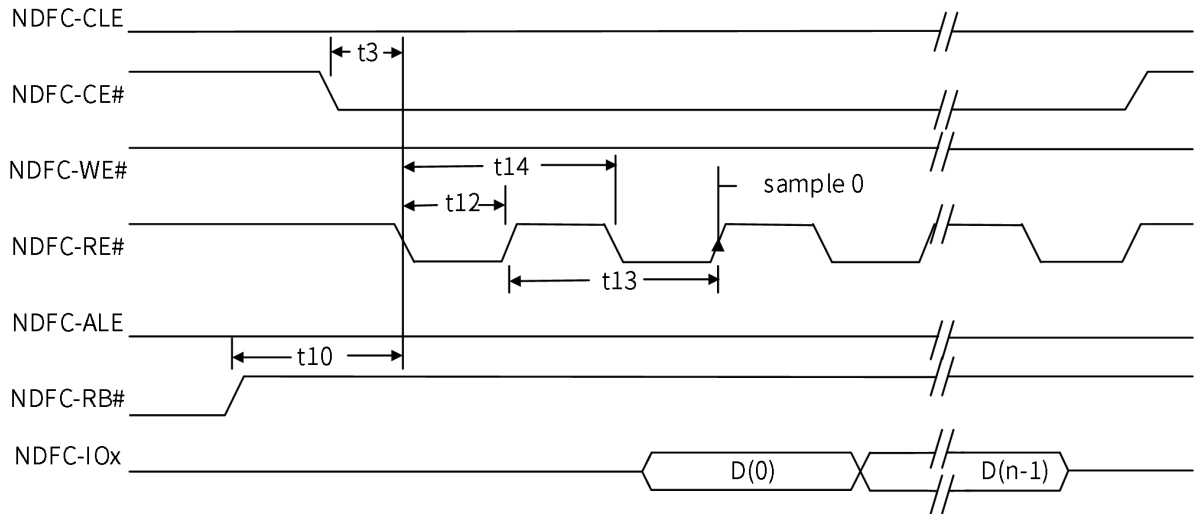

Figure 6-6 Command Latch Cycle Timing

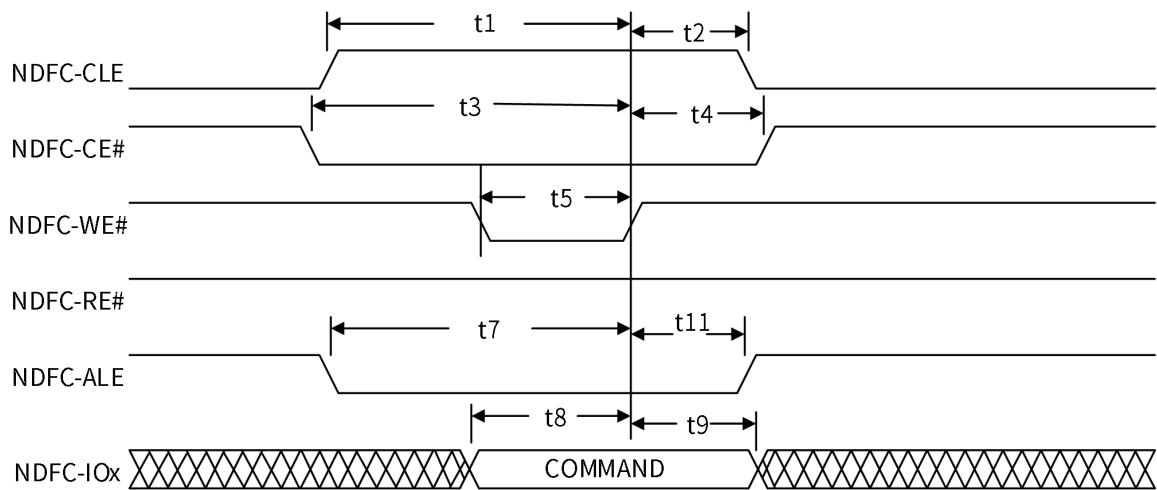

Figure 6-7 Address Latch Cycle Timing

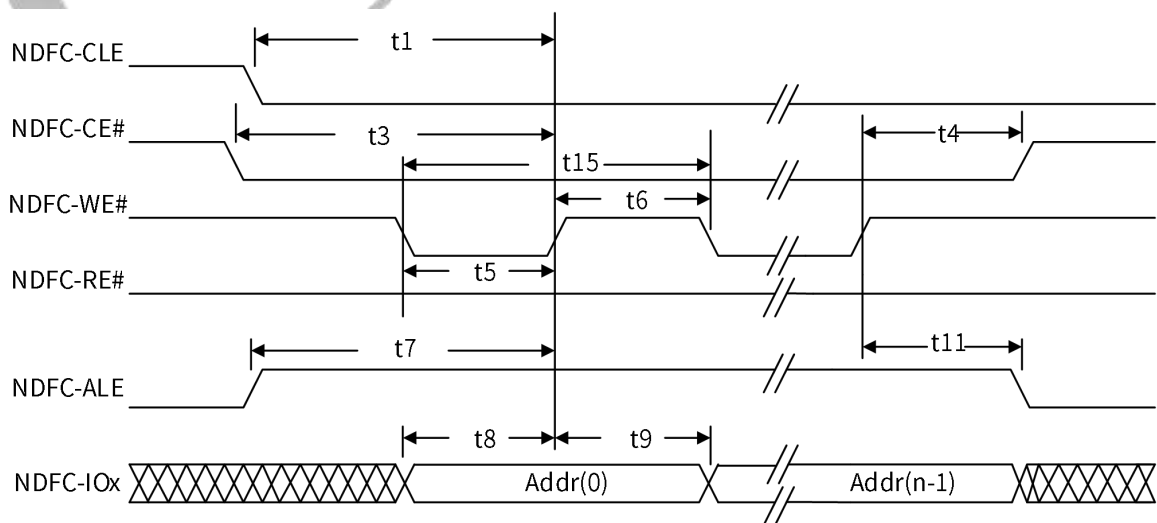

Figure 6-8 Write Data to Flash Cycle Timing

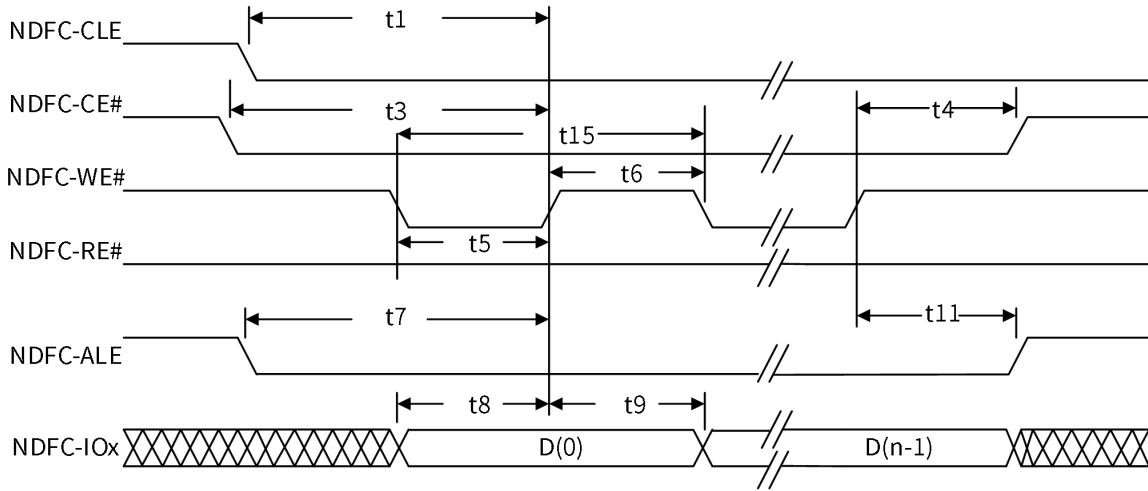

Figure 6-9 Waiting R/B# Ready Timing

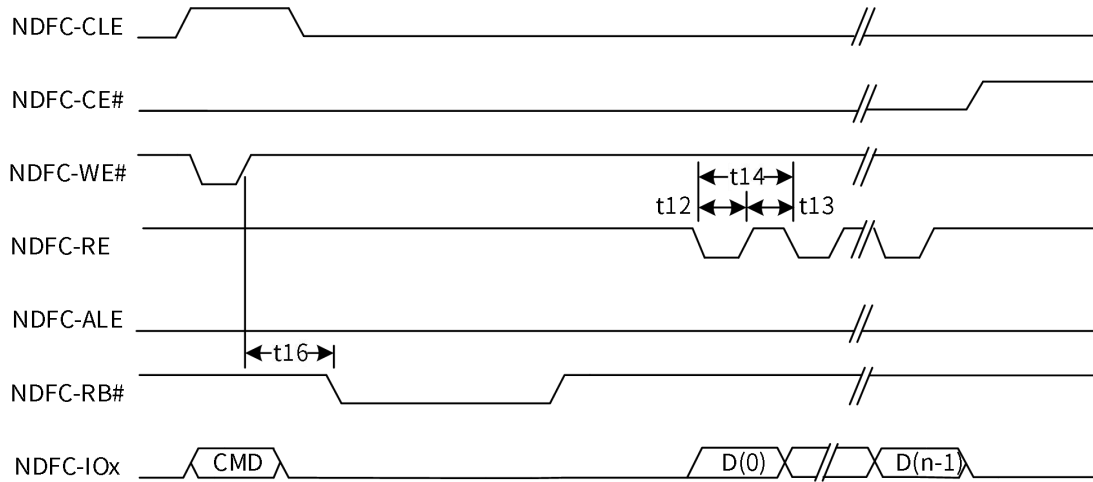

Figure 6-10 WE# High to RE# Low Timing

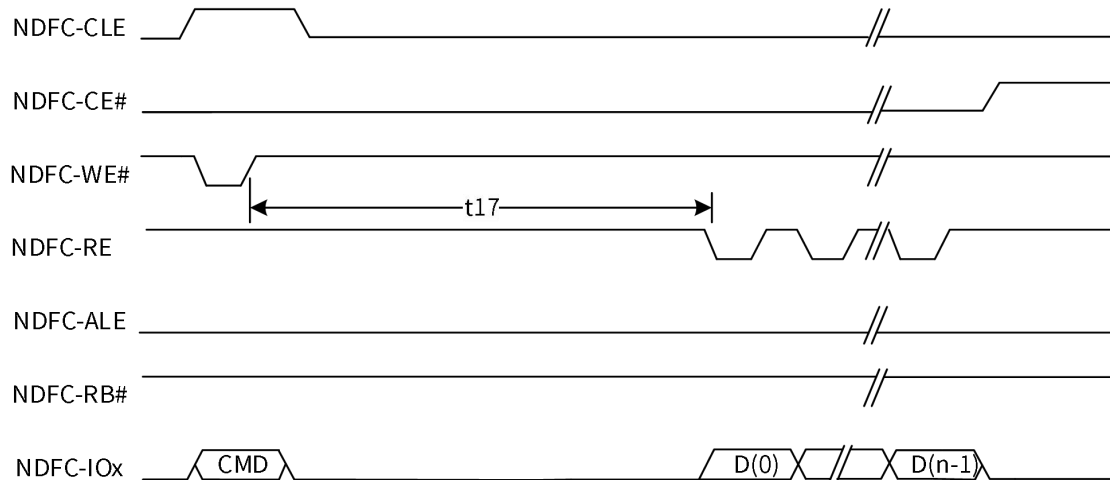

Figure 6-11 RE# High to WE# Low Timing

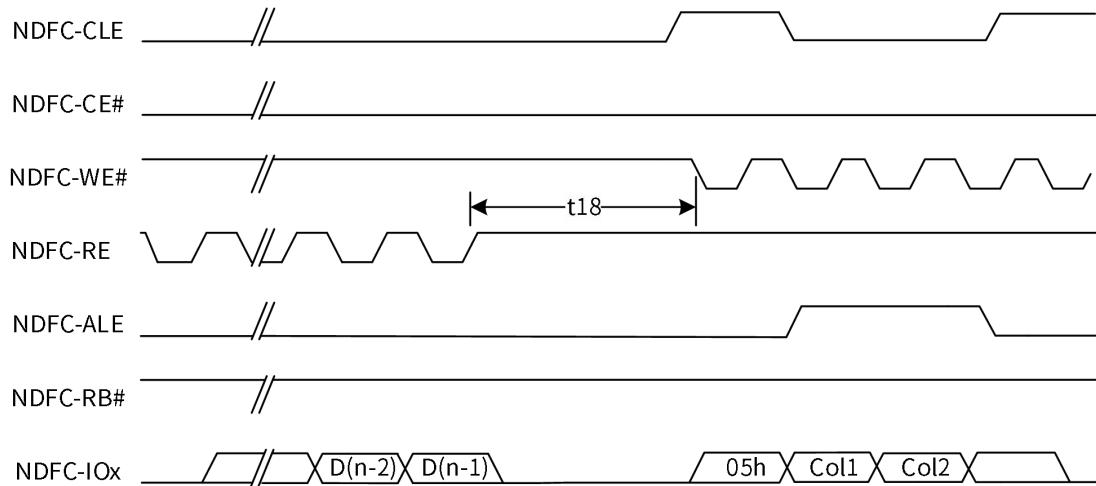

Figure 6-12 Address to Data Loading Timing

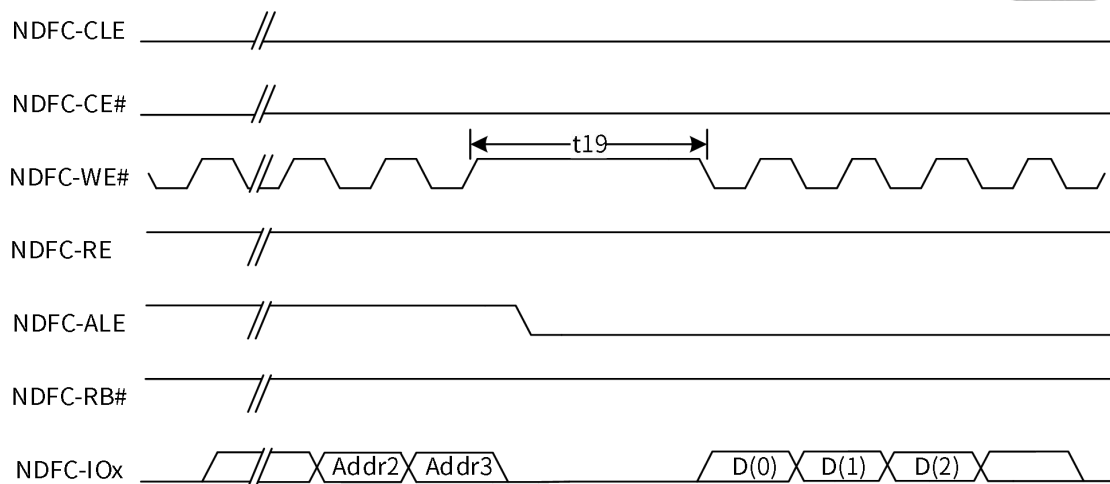

Table 6-15 NDFC Timing Constants

Parameter	Symbol	Timing	Unit
NDFC-CLE setup time	t1	2T	ns
NDFC-CLE hold time	t2	2T	ns
NDFC-CE setup time	t3	2T	ns
NDFC-CE hold time	t4	2T	ns
NDFC-WE# pulse width	t5	T ⁽¹⁾	ns
NDFC-WE# hold time	t6	T	ns
NDFC-ALE setup time	t7	2T	ns
Data setup time	t8	T	ns
Data hold time	t9	T	ns
Ready to NDFC-RE# low	t10	3T	ns

Parameter	Symbol	Timing	Unit
NDFC-ALE hold time	t11	2T	ns
NDFC-RE# pulse width	t12	T	ns
NDFC-RE# hold time	t13	T	ns
Read cycle time	t14	2T	ns
Write cycle time	t15	2T	ns
NDFC-WE# high to R/B# busy	t16	T_WB ⁽²⁾	ns
NDFC-WE# high to NDFC-RE# low	t17	T_WHR ⁽³⁾	ns
NDFC-RE# high to NDFC-WE# low	t18	T_RHW ⁽⁴⁾	ns
Address to Data Loading time	t19	T_ADL ⁽⁵⁾	ns

(1) T is the cycle of internal clock.
 (2), (3), (4), (5) This values are configurable in NAND Flash controller. The value of T_WB could be 14*2T/22*2T/30*2T/38*2T, the value of T_WHR could be 8*2T/16*2T/24*2T/32*2T, the value of T_RHW could be 4*2T/8*2T/12*2T/20*2T, the value of T_ADL could be 0*2T/8*2T/16*2T/24*2T.

6.11.2 SMHC Interface Timing

6.11.2.1 HS-SDR Mode

NOTE

IO voltage is 1.8V or 3.3V.

Figure 6-13 SMHC HS-SDR Mode Output Timing Diagram

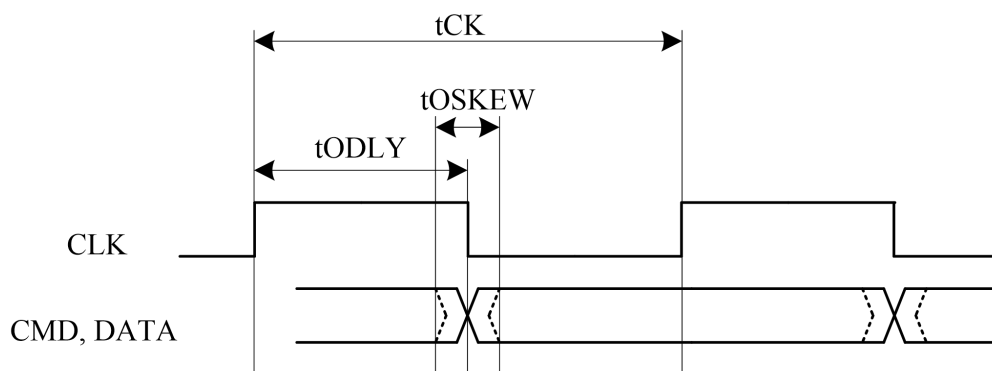

Table 6-16 SMHC HS-SDR Mode Output Timing Constants

Parameter	Symbol	Min	Typ	Max	Unit
CLK					
Clock frequency	tCK	0	50	50	MHz
Duty Cycle	DC	45	50	55	%
Output CMD, DATA(referenced to CLK)					
CMD, Data output delay time	tODLY	-	0.25	0.5	UI
Data output delay skew time	tOSKEW	-	-	0.884	ns
(1) The Unit Interval (UI) is 1-bit nominal time. For example, UI=20 ns at 50 MHz.					
(2) The driver strength level of GPIO is 2 for test.					

Figure 6-14 SMHC HS-SDR Mode Input Timing Diagram

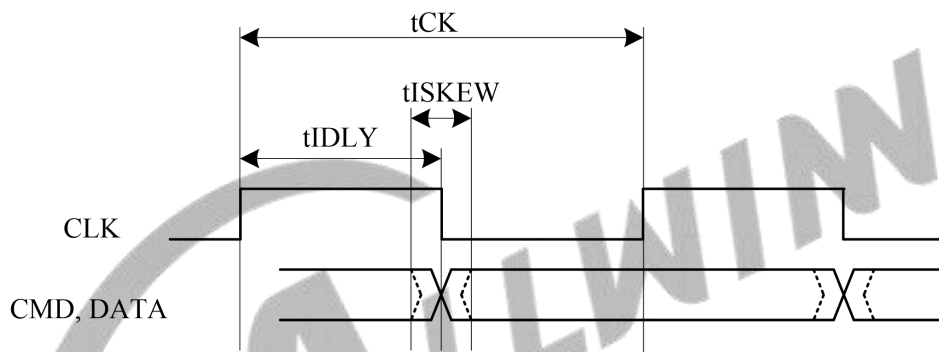

Table 6-17 SMHC HS-SDR Mode Input Timing Constants

Parameter	Symbol	Min	Typ	Max	Unit
CLK					
Clock frequency	tCK	0	50	50	MHz
Duty Cycle	DC	45	50	55	%
Input CMD, DATA(referenced to CLK 50MHz)					
Data input delay in SDR mode. It includes the PCB delay time of Clock, the PCB delay time of Data and the data output delay of Device	tIDLY	-	-	20	ns
Data input skew time in SDR mode	tISKEW	-	-	0.858	ns
The driver strength level of GPIO is 2 for test.					

6.11.2.2 HS-DDR Mode

Figure 6-15 SMHC HS-DDR Mode Output Timing Diagram

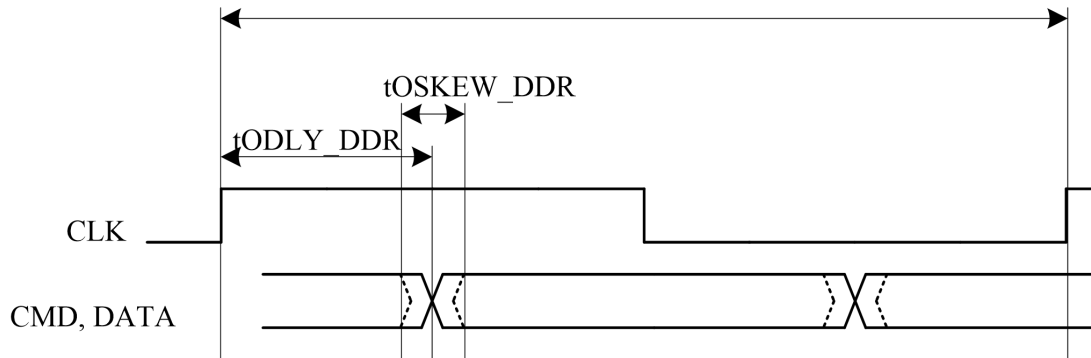

Table 6-18 SMHC HS-DDR Mode Output Timing Constants

Parameter	Symbol	Min	Typ	Max	Unit
CLK					
Clock frequency	tCK	0	50	50	MHz
Duty Cycle	DC	45	50	55	%
Output CMD, DATA(referenced to CLK)					
CMD, Data output delay time in DDR mode	tODLY-DDR	-	0.25	0.25	UI
Data output delay skew time	tOSKEW	-	-	0.884	ns
(1) The Unit Interval (UI) is 1-bit nominal time. For example, UI=20 ns at 50 MHz.					
(2) The driver strength level of GPIO is 2 for test.					

Figure 6-16 SMHC HS-DDR Mode Input Timing Diagram

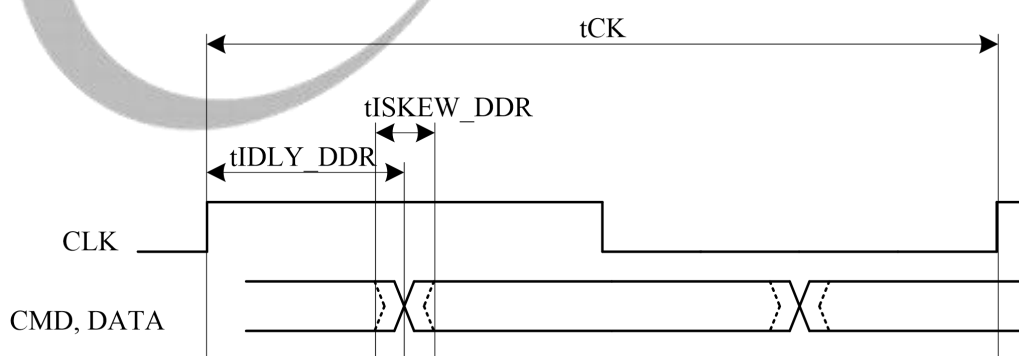

Table 6-19 SMHC HS-DDR Mode Input Timing Constants

Parameter	Symbol	Min	Typ	Max	Unit
CLK					

Parameter	Symbol	Min	Typ	Max	Unit
Clock frequency	tCK	0	50	50	MHz
Duty Cycle	DC	45	50	55	%
Input CMD, DATA(referenced to CLK 50MHz)					
Data input delay in DDR mode. It includes the PCB delay time of Clock, the PCB delay time of Data and the data output delay of Device	tIDLY-DDR	-	-	8.3	ns
Data input skew time in DDR mode	tISKEW-DDR	-	-	0.858	ns
The driver strength level of GPIO is 2 for test.					

6.11.2.3 HS200/SDR104 Mode

Figure 6-17 SMHC HS200/SDR104 Mode Output Timing Diagram

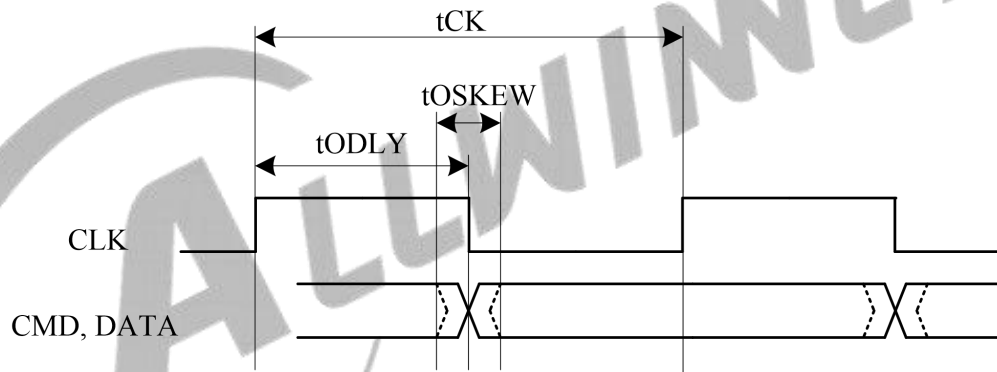

Table 6-20 SMHC HS200/SDR104 Mode Output Timing Constants

Parameter	Symbol	Min	Typ	Max	Unit
CLK					
Clock frequency	tCK	-	-	200	MHz
Duty Cycle	DC	45	50	55	%
Rise time, fall time	tTLH, tTHL	-	-	0.2	UI
Output CMD, DATA (referenced to CLK)					
CMD, Data output delay time	tODLY	-	0.25	0.5	UI
Data output delay skew time	tOSKEW	-	-	0.884	ns
(1) The Unit Interval (UI) is 1-bit nominal time. For example, UI=10 ns at 100 MHz.					
(2) The driver strength level of GPIO is 3 for test.					

Figure 6-18 SMHC HS200/SDR104 Mode Input Timing Diagram

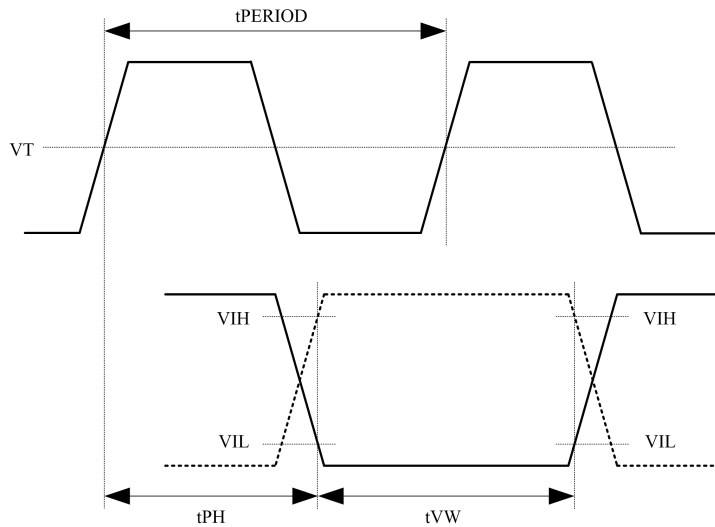

Table 6-21 SMHC HS200 Mode Input Timing Constants

Parameter	Symbol	Min	Typ	Max	Unit	Remark
CLK						
Clock Period	tPERIOD	5	-	-	ns	Max: 200 MHz
Duty Cycle	DC	45	50	55	%	
Rise time, fall time	tTLH, tTHL	-	-	0.2	UI	
Input CMD, DATA (referenced to CLK)						
Output delay	tPH	0	-	2	UI	
Output delay variation due to temperature change after tuning	dPH	-350 ⁽³⁾	-	1550 ⁽⁴⁾	ps	
CMD, Data valid window	tVW	0.575	-	-	UI	
(1) The Unit Interval (UI) is 1-bit nominal time. For example, UI=10 ns at 100 MHz. (2) The driver strength level of GPIO is 3 for test. (3) Temperature variation: -20 °C. (4) Temperature variation: 90 °C.						

6.11.2.4 HS400 Mode

The CMD output timing for HS400 mode is the same as CMD output timing for HS200 mode.

Figure 6-19 SMHC HS400 Mode Output Timing Diagram

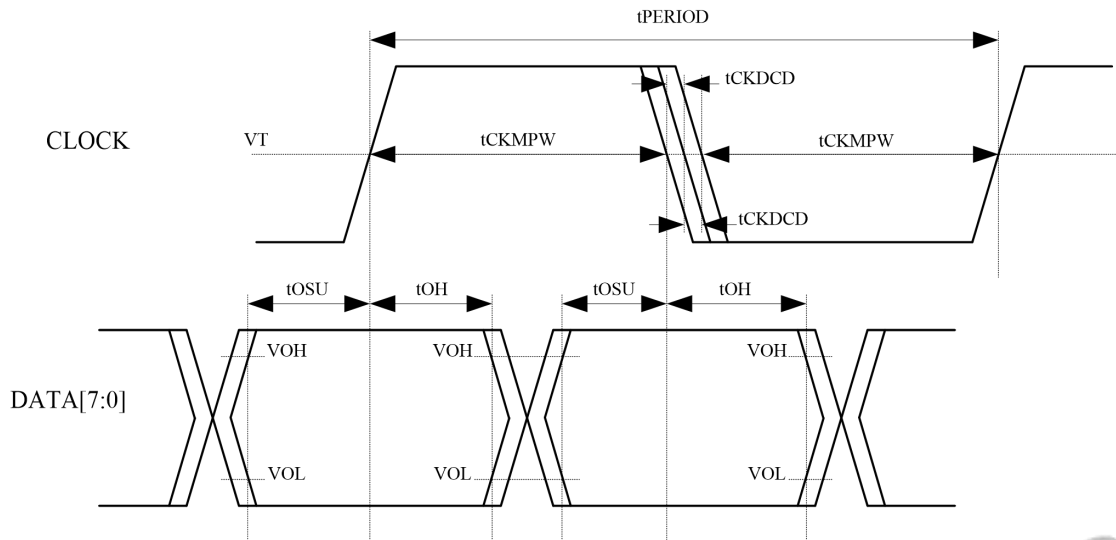

Table 6-22 SMHC HS400 Mode Output Timing Constants

Parameter	Symbol	Min	Typ	Max	Unit	Remark
CLK						
Clock period	tPERIOD	5	-	-	ns	Max: 200 MHz
Clock slew rate	SR	1.125	-	-	V/ns	
Clock duty cycle distortion	tCKDCCD	0	-	0.5	ns	
Clock minimum pulse width	tCKMPW	2.2	-	-	ns	
Output DATA (referenced to CLK)						
Data output setup time	tOSU	0.4	-	-	ns	
Data output hold time	tOH	0.4	-	-	ns	
Data output slew rate	SR	0.9	-	-	V/ns	
(1) The Unit Interval (UI) is 1-bit nominal time. For example, UI=10 ns at 100 MHz.						
(2) The driver strength level of GPIO is 3 for test.						

Figure 6-20 SMHC HS400 Mode Input Timing Diagram

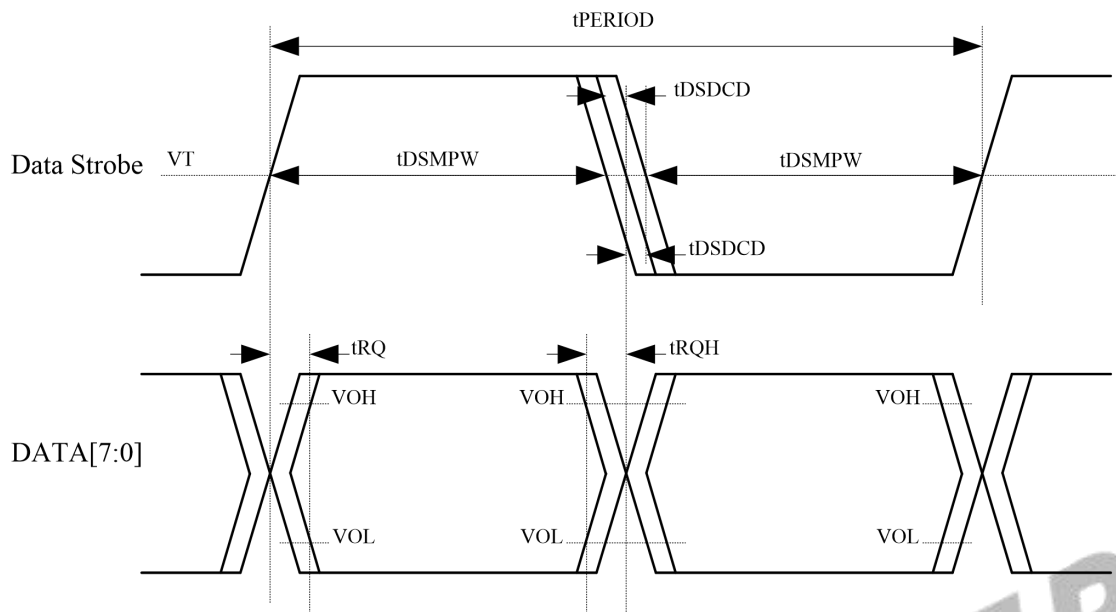

Table 6-23 SMHC HS400 Mode Input Timing Constants

Parameter	Symbol	Min	Typ	Max	Unit	Remark
DS (Data Strobe)						
DS period	tPERIOD	5	-	-	ns	Max: 200 MHz
DS slew rate	SR	1.125	-	-	V/ns	
DS duty cycle distortion	tDSDCD	0.0	-	0.4	ns	
DS minimum pulse width	tDSMPW	2.0	-	-	ns	
Output DATA (referenced to CLK)						
Data input skew	tRQ	-	-	0.4	ns	
Data input hold skew	tRQH	-	-	0.4	ns	
Data input slew rate	SR	0.85	-	-	V/ns	
(1) The Unit Interval (UI) is 1-bit nominal time. For example, UI=10 ns at 100 MHz.						
(2) The driver strength level of GPIO is 3 for test.						

6.11.3 UART Interface Timing

Figure 6-21 UART RX Timing

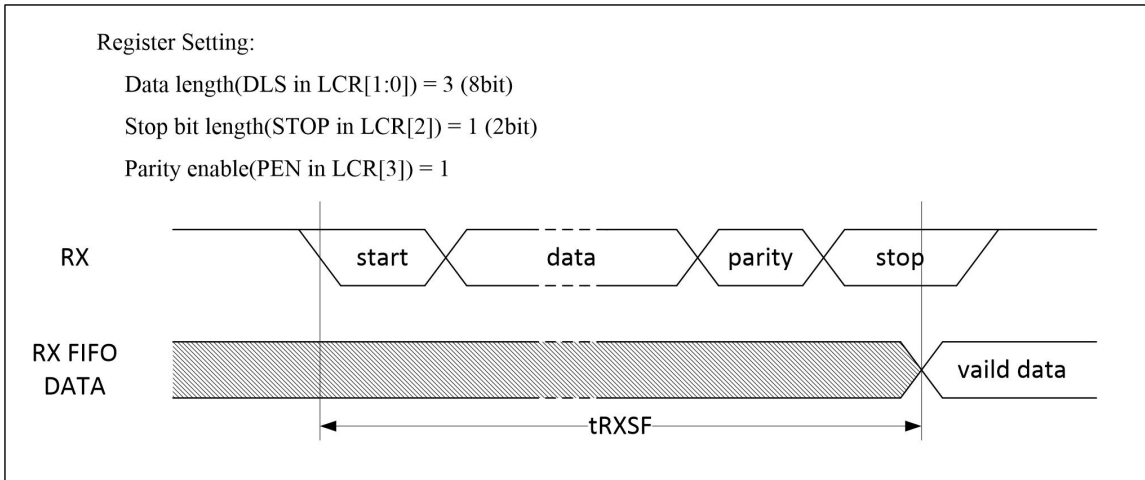

Figure 6-22 UART nCTS Timing

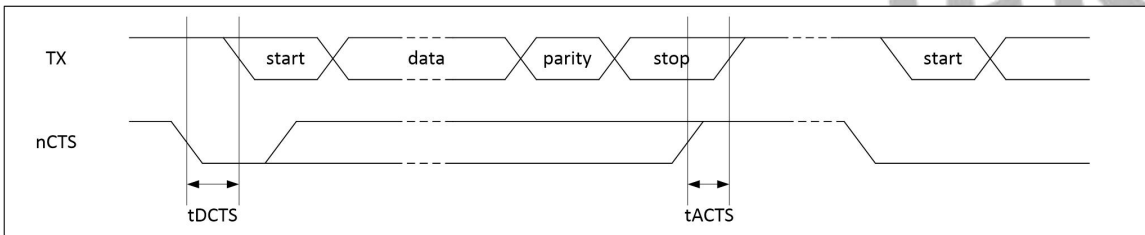

Figure 6-23 UART nRTS Timing

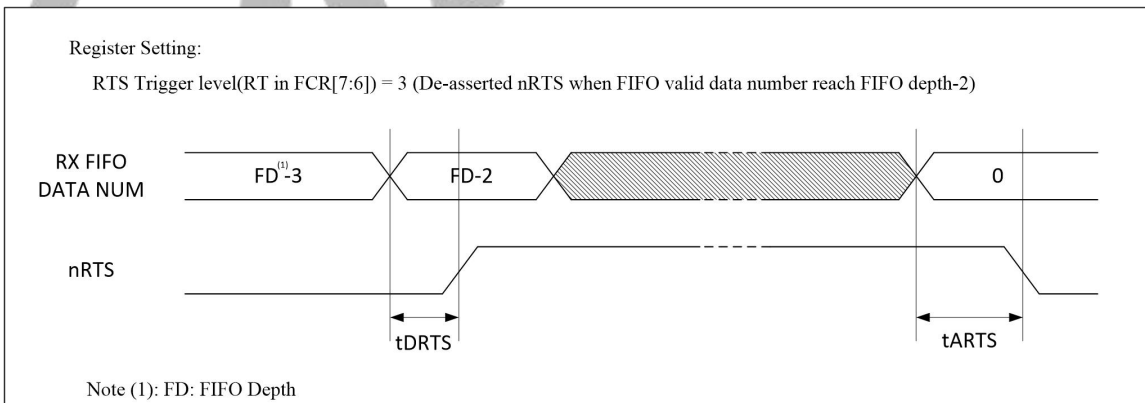

Table 6-24 UART Timing Constants

Parameter	Symbol	Min	Typ	Max	Unit
RX start to RX FIFO	tRXSF	10.5*BRP ⁽¹⁾	-	11*BRP ⁽¹⁾	ns
Delay time of de-asserted nCTS to TX strat	tDCTS	-	-	BRP ⁽¹⁾	ns
Step time of asserted nCTS to stop next transmission	tACTS	BRP ⁽¹⁾ /4	-	-	ns

Parameter	Symbol	Min	Typ	Max	Unit
Delay time of de-asserted nRTS	tDRTS	-	-	BRP ⁽¹⁾	ns
Delay time of asserted nRTS	tARTS	-	-	BRP ⁽¹⁾	ns

(1) BRP: Baud-Rate Period.

6.11.4 SPI Interface Timing

Figure 6-24 SPI Writing Timing

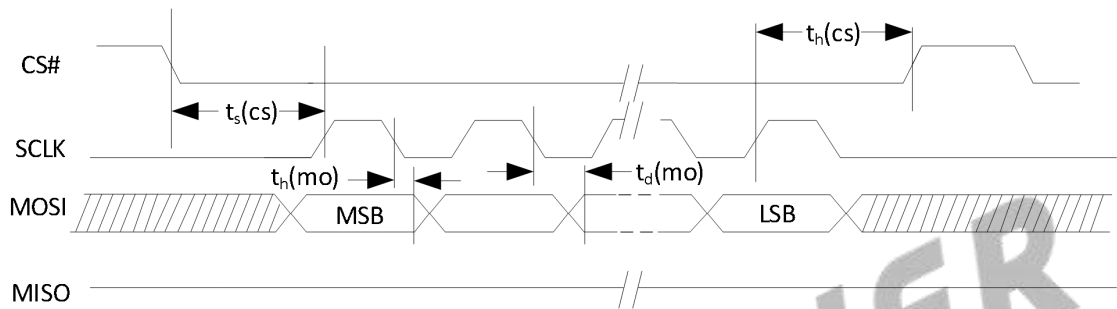

Figure 6-25 SPI Reading Timing

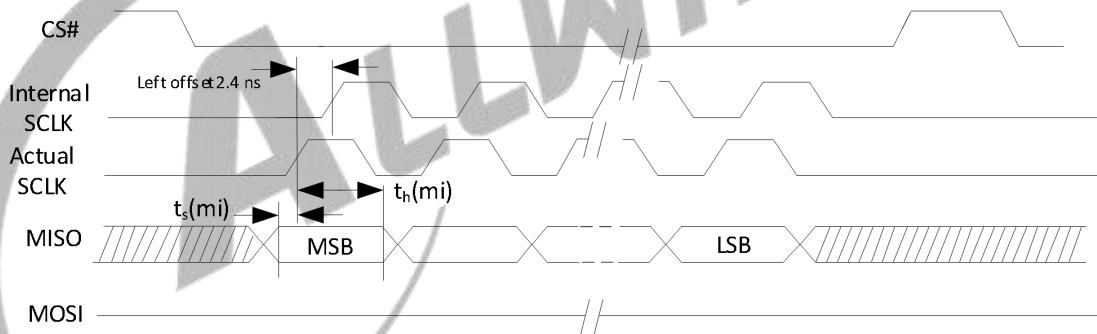

Table 6-25 SPI Timing Constants

Parameter	Symbol	Min	Typ	Max	Unit
CS# Active Setup Time	$t_s(cs)$	-	$2T^{(1)}$	-	ns
CS# Active Hold Time	$t_h(cs)$	-	$2T^{(1)}$	-	ns
Data output Delay Time	$t_v(mo)$	-	$T^{(1)}/2-3$	-	ns
Data output Hold Time	$t_h(mo)$	-	$T^{(1)}/2-3$	-	ns
Data In Setup Time	$t_s(mi)$	0.2	-	-	ns
Data In Hold Time	$t_h(mi)$	0.2	-	-	ns

(1) T is the cycle of clock.

6.11.5 SPI-DBI Interface Timing

Figure 6-26 DBI 3-line Serial Interface Timing

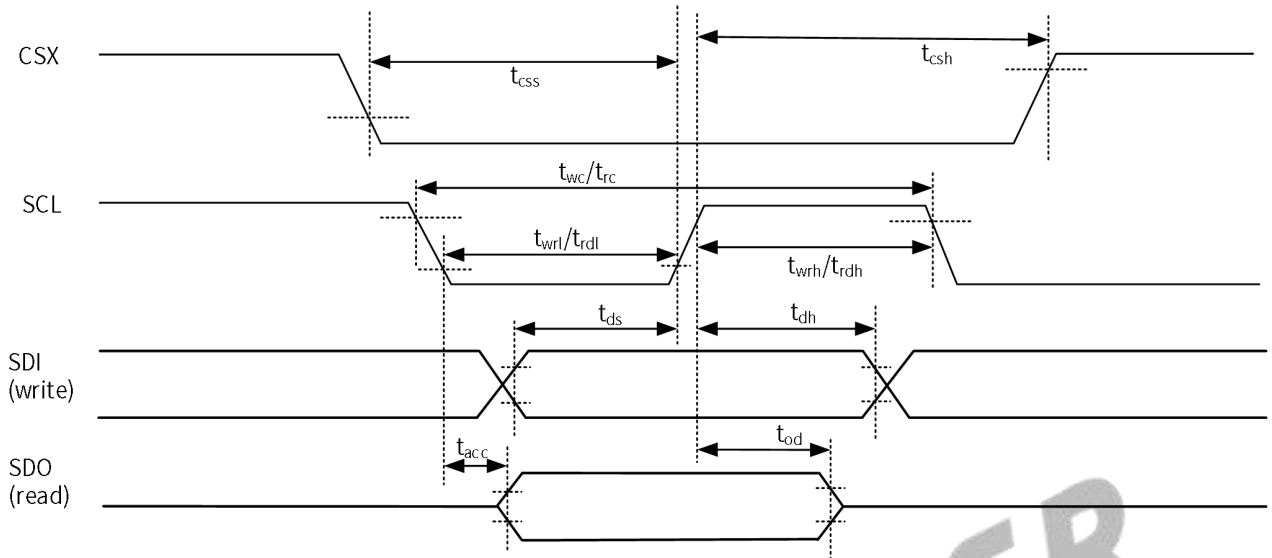

Table 6-26 DBI 3-line Serial Interface Write Timing Parameters

Signal	Parameter	Symbol	Min	Max	Unit
CSX	Chip select setup time	t_{css}	15		ns
SCL	Write cycle	t_{wc}	16		ns
	Control pulse "H" duration	t_{wrh}	7		ns
	Control pulse "L" duration	t_{wrl}	7		ns
SDI/SDO	Data setup time	t_{ds}	7 ⁽¹⁾		ns
	Data hold time	t_{dt}	7 ⁽¹⁾		ns

Note:

Range of required clock frequency: 0-60 MHz.

Table 6-27 DBI 3-line Serial Interface Read Timing Parameters

Signal	Parameter	Symbol	Min	Max	Unit
CSX	Chip select setup time	t_{csh}	60		ns
SCL	Read cycle	t_{rc}	150		ns
	Control pulse "H" duration	t_{rdh}	60		ns
	Control pulse "L" duration	t_{rdl}	60		ns
SDI/SDO	Read access time	t_{racc}	10 ⁽¹⁾	50	ns
	Output disable time	t_{od}	15 ⁽¹⁾	50	ns

Signal	Parameter	Symbol	Min	Max	Unit
Note:					
Range of required clock frequency: 0-6.67 MHz.					

Figure 6-27 DBI 4-line Serial Interface Timing

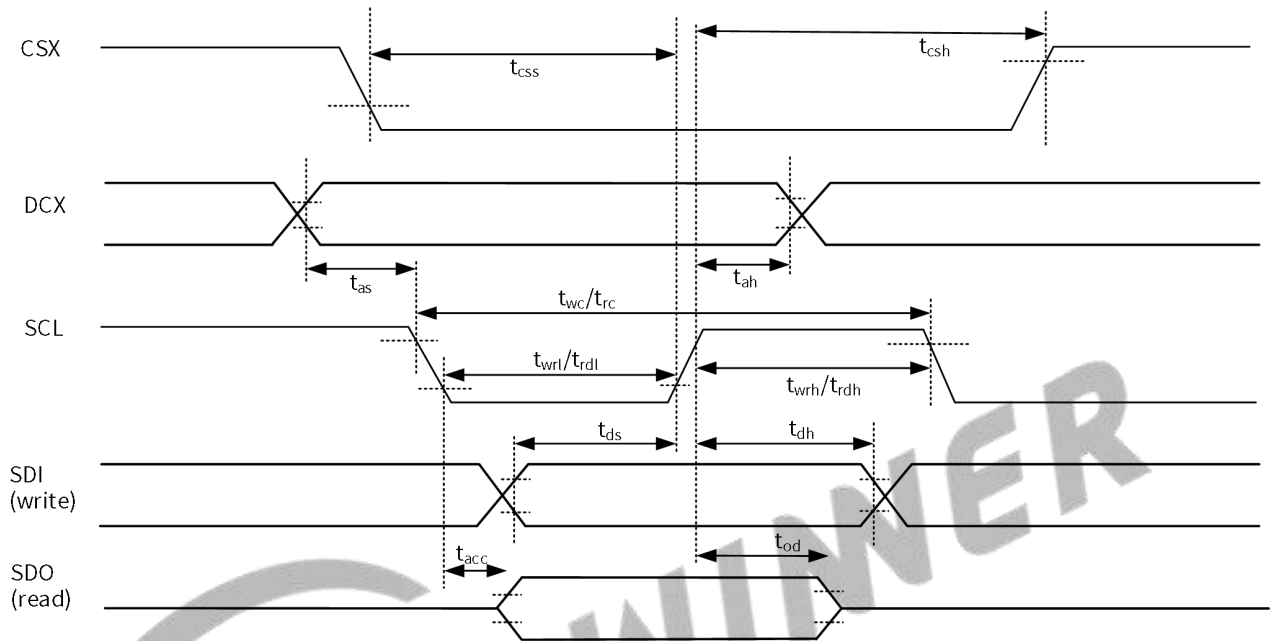

Table 6-28 DBI 4-line Serial Interface Write Timing Parameters

Signal	Parameter	Symbol	Min	Max	Unit
CSX	Chip select setup time	t_{css}	15		ns
DCX	Address setup time	t_{as}	10		ns
	Address hold time	t_{ah}	10		ns
SCL	Write cycle	t_{wc}	16		ns
	Control pulse “H” duration	t_{wrh}	7		ns
	Control pulse “L” duration	t_{wrl}	7		ns
SDI/SDO	Data setup time	t_{ds}	7 ⁽¹⁾		ns
	Data hold time	t_{dt}	7 ⁽¹⁾		ns
	Output disable time	t_{od}	15 ⁽¹⁾	50	ns

Signal	Parameter	Symbol	Min	Max	Unit
Note:					
Range of required clock frequency: 0-60 MHz.					

Table 6-29 DBI 4-line Serial Interface Read Timing Parameters

Signal	Parameter	Symbol	Min	Max	Unit
CSX	Chip select setup time	t_{csh}	60		ns
DCX	Address setup time	t_{as}	10		ns
	Address hold time	t_{ah}	10		ns
SCL	Read cycle	t_{rc}	150		ns
	Control pulse “H” duration	t_{rdh}	60		ns
	Control pulse “L” duration	t_{rdl}	60		ns
SDI/SDO	Read access time	t_{racc}	-	50	ns
	Output disable time	t_{od}	15 ⁽¹⁾	50	ns

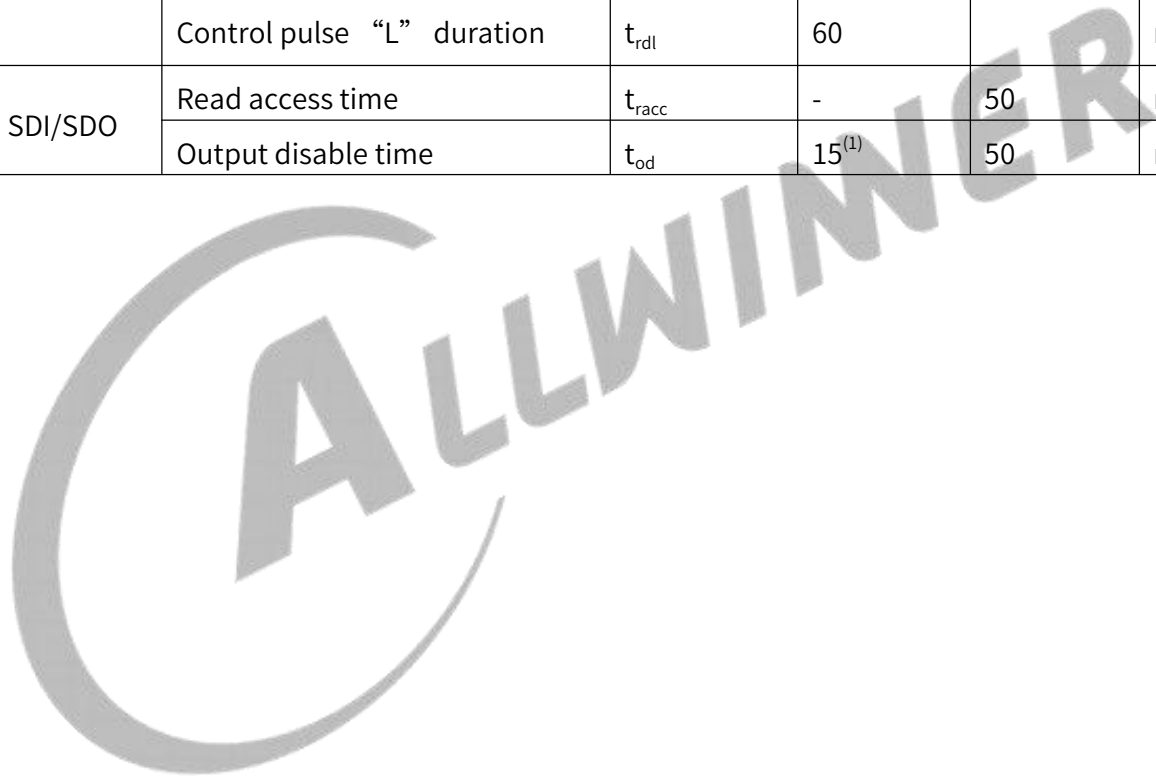

Signal	Parameter	Symbol	Min	Max	Unit
Note:					
Range of required clock frequency: 0-6.67 MHz.					

6.11.6 SPI Flash Interface Timing

6.11.6.1 Controller Output to Target Input Timing

Figure 6-28 xSPI Target Data Input Timing

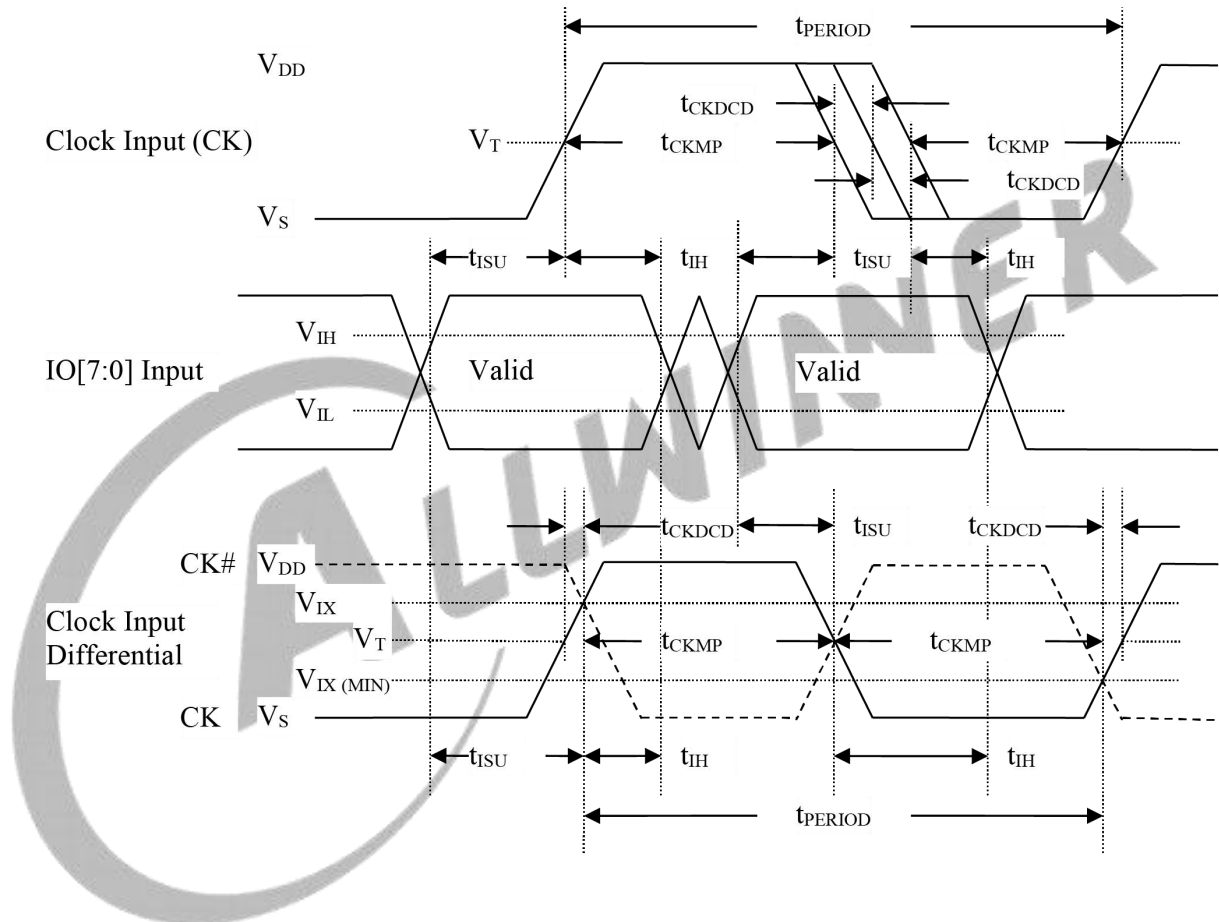

Table 6-30 Clock Input Threshold Levels

Parameter	Symbol	Min	Max	Unit
Clock Input Threshold (AC)	$V_{T(AC)}$	$0.50 * V_{DD}$	$0.50 * V_{DD}$	V
Input differential crossing (AC)	$V_{IX(AC)}$	$0.4 * V_{DD}$	$0.60 * V_{DD}$	V

Table 6-31 xSPI Device Input Timing

Parameter	Symbol	xSPI-333 ⁽¹⁾		xSPI-266 ⁽²⁾		xSPI-200 ⁽³⁾		Unit	Comments
		Min	Max	Min	Max	Min	Max		

Parameter	Symbol	xSPI-333 ⁽¹⁾		xSPI-266 ⁽²⁾		xSPI-200 ⁽³⁾		Unit	Comments
		Min	Max	Min	Max	Min	Max		
Input CK									
Cycle Time Data Transfer Mode	t_{PERIOD}	6	-	7.5	-	10	-	ns	150 MHz (max) between the rising edges with respect to V_T .
Slew Rate	SR	0.94	-	0.75	-	0.56	-	V/ns	With respect to V_{IH}/V_{IL} .
Duty Cycle Distortion	t_{CKDCD}	0.0	0.3	0.0	0.375	0.0	0.5	ns	Allowable deviation from an ideal 50% duty cycle with respect to V_T . Includes jitter and phase noise.
Minimum Pulse Width	t_{CKMPW}	2.7	-	3.375	-	4.5	-	ns	With respect to V_T .
Input Signals (Referenced to CK)									
Input Setup Time (DTR)	t_{ISUddr}	0.6	-	0.8	-	1.0	-	ns	With respect to V_{IH}/V_{IL} .
Input Hold Time (DTR)	t_{IHddr}	0.6	-	0.8	-	1.0	-	ns	With respect to V_{IH}/V_{IL} .
Input Setup Time (STR)	t_{ISU}	1	-	2	-	2	-	ns	With respect to V_{IH}/V_{IL} .
Input Hold Time (STR)	t_{IH}	1	-	2	-	2	-	ns	With respect to V_{IH}/V_{IL} .
Slew Rate @ 1.8 V	SR	0.94	--	0.75	-	0.56	-	V/ns	With respect to V_{IH}/V_{IL} and xSPI reference load.
Slew Rate @ 3.0 V	SR	1.72	-	1.37	-	1.03	-	V/ns	With respect to V_{IH}/V_{IL} and xSPI reference load.

Parameter	Symbol	xSPI-333 ⁽¹⁾		xSPI-266 ⁽²⁾		xSPI-200 ⁽³⁾		Unit	Comments
		Min	Max	Min	Max	Min	Max		
Note:									
(1) xSPI-333: Up to 166 MHz; up to 333 MT/s.									
(2) xSPI-266: Up to 133 MHz; up to 266 MT/s.									
(3) xSPI-200: Up to 100 MHz; up to 200 MT/s.									

6.11.6.2 Target Output to Controller Input Timing

Figure 6-29 xSPI Target Data Output Timing

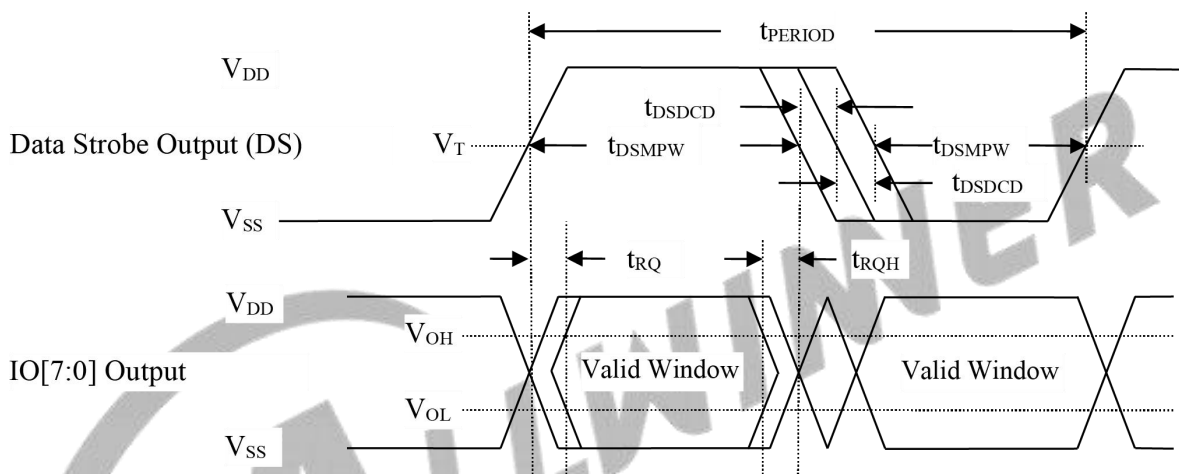

Table 6-32 xSPI Device Output Timing

Parameter	Symbol	xSPI-200 ⁽¹⁾		Unit	Comments
		Min	Max		
Data Strobe⁽²⁾					
Cycle Time Data Transfer Mode	t_{PERIOD}	10	-	ns	100 MHz (max) between the rising edges with respect to V_T .
Duty Cycle Distortion	t_{DSDCD}	0.0	0.4	ns	Allowable deviation from the input clock duty cycle distortion (t_{CKDCD}) with respect to V_T . Includes jitter and phase noise.
Minimum Pulse Width	t_{DSMPW}	4.1	-	ns	Minimum Pulse Width of DS is smaller than that of CK since the target is allowed to add distortion when generating DS from CK. With respect to V_T .

Parameter	Symbol	xSPI-200 ⁽¹⁾		Unit	Comments
		Min	Max		
Output DATA (Referenced to DS)					
Output skew	t_{RQ}	-	0.8	ns	With respect to V_{OH}/V_{OL} and xSPI reference load.
Output hold skew	t_{RQH}	-	0.8	ns	With respect to V_{OH}/V_{OL} and xSPI reference load.
Note:					
(1) xSPI-200: Up to 100 MHz; up to 200 MT/s.					
(2) Controller CK edges are the trigger for target IO and DS edges. IO and DS edges therefore always follow their related (triggering) CK edges.					

6.11.7 TWI Interface Timing

Figure 6-30 TWI Timing

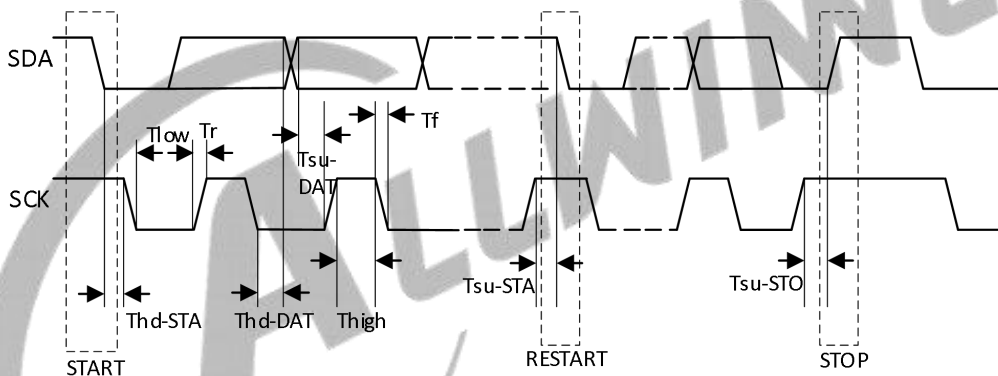

Table 6-33 TWI Timing Parameters

Parameter	Symbol	Standard mode		Fast mode		Unit
		Min	Max	Min	Max	
SCK clock frequency	Fsck	0	100	0	400	kHz
Setup Time In Start	Tsu-STA	4.7	-	0.6	-	us
Hold Time In Start	Thd-STA	4.0	-	0.6	-	us
Setup Time In Data	Tsu-DAT	250	-	100	-	ns
Hold Time In Data	Thd-DAT	5.0	-	-	-	us
Setup Time In Stop	Tsu-STO	4.0	-	0.6	-	us
SCK Low level Time	Tlow	4.7	-	1.3	-	us
SCK High level Time	Thigh	4.0	-	0.6	-	us

Parameter	Symbol	Standard mode		Fast mode		Unit
		Min	Max	Min	Max	
SCK/SDA Falling Time	Tf	-	300	20	300	ns
SCK/SDA Rising Time	Tr	-	1000	20	300	ns

6.11.8 GMAC Interface Timing

6.11.8.1 RGMII

Figure 6-31 RGMII Receive Timing

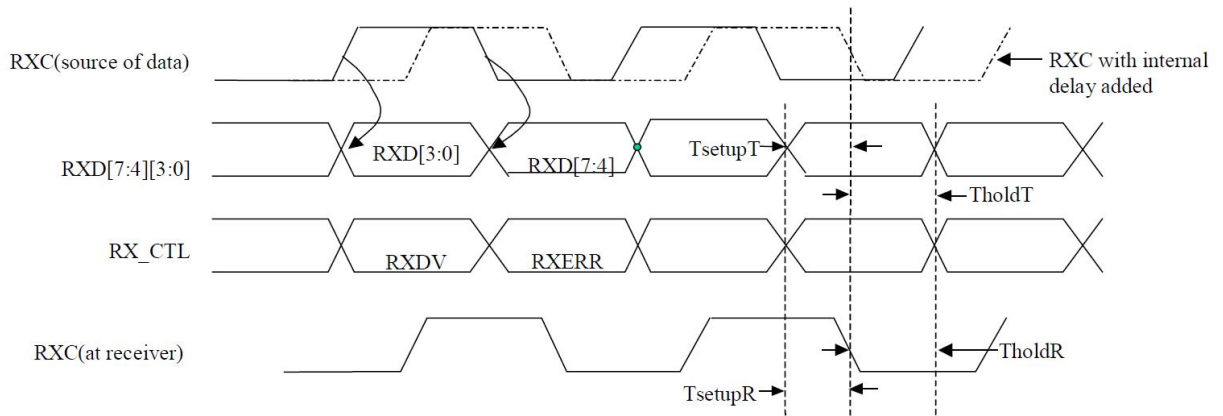

Figure 6-32 RGMII Transmit Timing

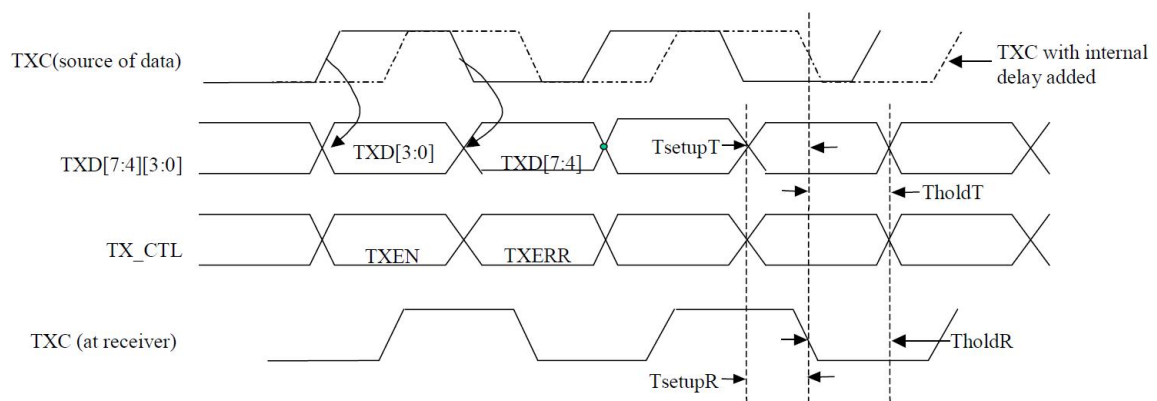

Table 6-34 RGMII Timing Constants

Parameter	Description	Min	Typical	Max	Unit
Tcyc	Clock Cycle Duration	7.2	8	8.8	ns
Duty_G	Duty Cycle Duration for Gigabit	45	50	55	%
Duty_T	Duty Cycle for 10/100T	40	50	60	%

Parameter	Description	Min	Typical	Max	Unit
TsetupT	Data to Clock Output Setup (at Transmitter Integrated Delay)	1.2	2.0	-	ns
TholdT	Data to Clock Output Hold (at Transmitter Integrated Delay)	1.2	2.0	-	ns
TsetupR	Data to Clock Input Setup (at Receiver Integrated Delay)	1.0	2.0	-	ns
TholdR	Data to Clock Input Hold (at Receiver Integrated Delay)	1.0	2.0	-	ns

For 10Mbps and 100Mbps, Tcyc will scale 400ns±40ns and 40ns±4ns.

6.11.8.2 RMII

Figure 6-33 RMII Receive Timing

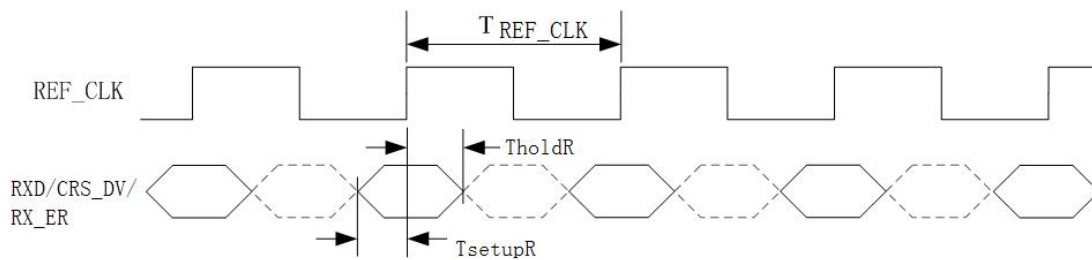

Figure 6-34 RMII Transmit Timing

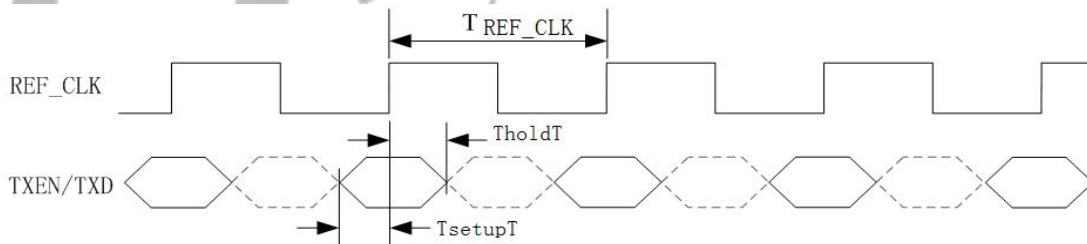

Table 6-35 RMII Timing Constants

Parameter	Description	Min	Typ	Max	Unit
T _{REF_CLK}	Reference Clock Period	-	20	-	ns
Tduty	REF_CLK Duty Cycle	35	-	65	%
TsetupT	TXD/TXEN to REF_CLK Setup Time	4	-	-	ns
TholdT	TXD/TXEN to REF_CLK Hold Time	2	-	-	ns
TsetupR	RXD/CRS_DV/RX_ER to REF_CLK Setup Time	4	-	-	ns
TholdR	RXD/CRS_DV/RX_ER to REF_CLK Hold Time	2	-	-	ns

6.11.9 MIPI DSI Interface Timing

Figure 6-35 MIPI DSI Timing

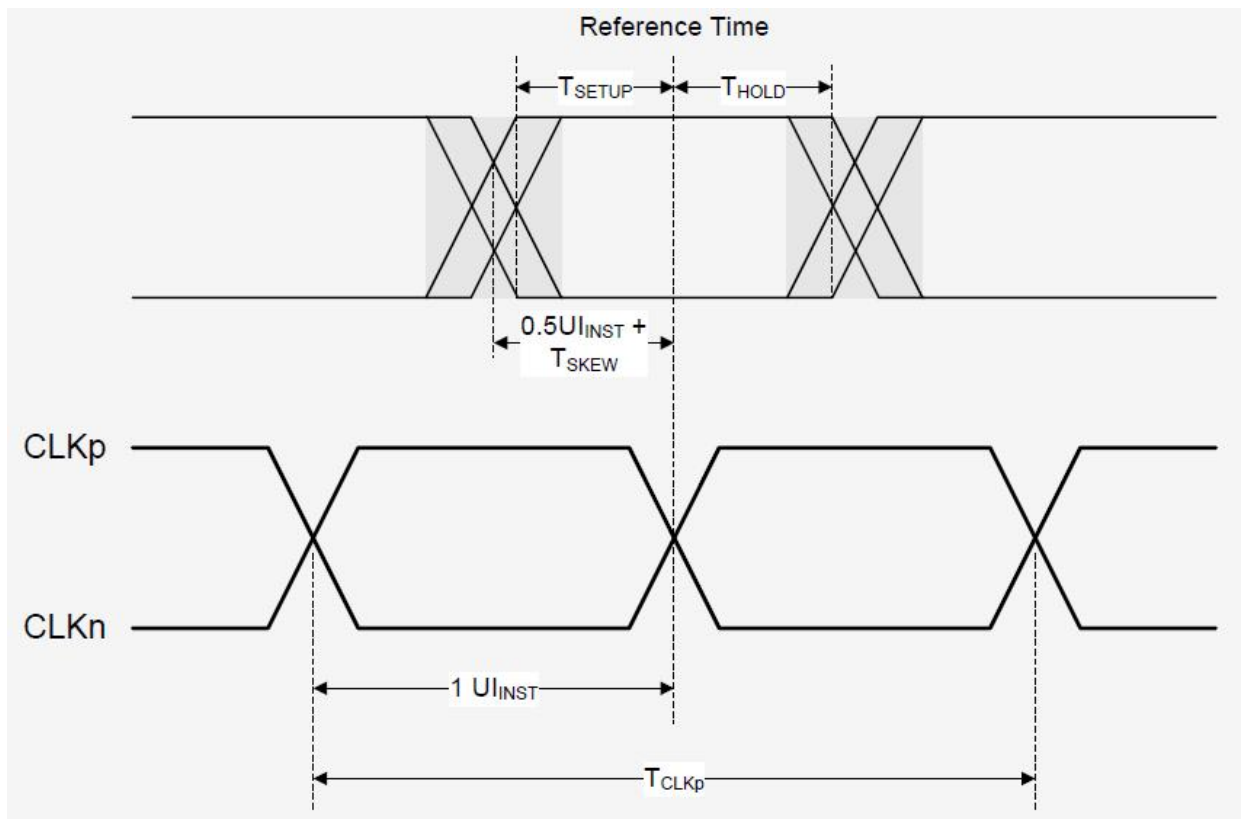

Table 6-36 MIPI DSI Timing Constants

Parameter	Symbol	Units in U _{INST}			Operational Frequency in Gbit/s	
		Min	Max	Total	Min	Max
Data to Clock Skew	$T_{skew[tx]}$	-0.15	0.15	0.3	0.08	1.0
		-0.20	0.20	0.4	>1.0	1.5
Data to Clock Setup Time	$T_{setup[rx]}$	0.15	-	-	0.08	1.0
		0.20			>1.0	1.5
Clock to Data Hold Time	$T_{hold[rx]}$	0.15	-	-	0.08	1.0
		0.20			>1.0	1.5

6.11.10 I2S/PCM Interface Timing

6.11.10.1 Data Output timing of I2S/PCM in Master mode

The Data Output timing of I2S/PCM in Master mode and the Data Input timing of Peripheral I2S/PCM in Slave mode show in Figure 6-36.

Figure 6-36 Data Output Timing of I2S/PCM in Master Mode

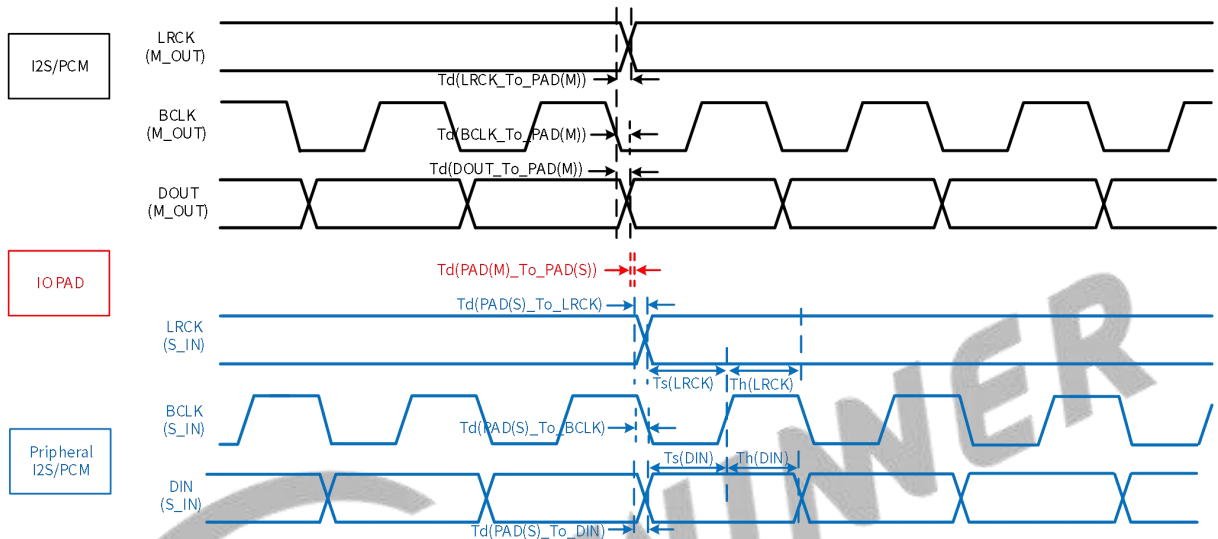

The Data Output timing parameters of I2S/PCM in Master mode and The Data Input timing parameters of Peripheral I2S/PCM in Slave mode show in Table 6-37.

Table 6-37 Data Output Timing Parameters of I2S/PCM in Master Mode

Parameter		Min	Max	Skew	Units
Sequence requirement of internal signal of I2S/PCM in Master mode					
$T_d(LRCK_To_PAD(M))$	LRCK to PAD(M) Delay	/	$T1 < 6.5$ (restriction)	$T_w1 < 2.5$ (requirement)	ns
$T_d(BCLK_To_PAD(M))$	BCLK to PAD(M) Delay	/	$T2 < 6.5$ (restriction)		
$T_d(DOUT_To_PAD(M))$	DOUT to PAD(M) Delay	/	$T3 < 6.5$ (restriction)		
Sequence requirement of the IO pad of I2S/PCM in Master mode connecting to the external IO pad of Peripheral I2S/PCM in Slave mode					
$T_d(PAD(M)_To_PAD(S))$	LRCK PAD(M) to LRCK PAD(S) Delay	/	$T4^* < 7.0$ (estimation)	$T_w2^* < 1.0$ (requirement)	ns

Parameter		Min	Max	Skew	Units
	BCLK PAD(M) to BCLK PAD(S) Delay	/	$T5^* < 7.0$ (estimation)		
	DOUT PAD(M) to DIN PAD(S) Delay	/	$T6^* < 7.0$ (estimation)		
Sequence requirement of internal signal of Peripheral I2S/PCM in Slave mode					
T_d (PAD(S)_To_LRCK)	PAD(S) to LRCK Delay	/	$T7^* < 6.5$ (assumption)	$T_w3^* < 2.5$ (requirement)	ns
T_d (PAD(S)_To_BCLK)	PAD(S) to BCLK Delay	/	$T8^* < 6.5$ (assumption)		
T_d (PAD(S)_To_DIN)	PAD(S) to DIN Delay	/	$T9^* < 6.5$ (assumption)		
T_s (LRCK)	LRCK Setup Slack	$T10^*$ (analysis)	/	/	ns
T_h (LRCK)	LRCK Hold Slack	$T11^*$ (analysis)	/	/	ns
T_s (DIN)	DIN Setup Slack	$T12^*$ (analysis)	/	/	ns
T_h (DIN)	DIN Hold Slack	$T13^*$ (analysis)	/	/	ns

6.1.1.10.2 Data Input timing of I2S/PCM in Master mode

The Data Input timing of I2S/PCM in Master mode and the Data Output timing of Peripheral I2S/PCM in Slave mode show in Figure 6-37.

Figure 6-37 Data Input Timing of I2S/PCM in Master Mode

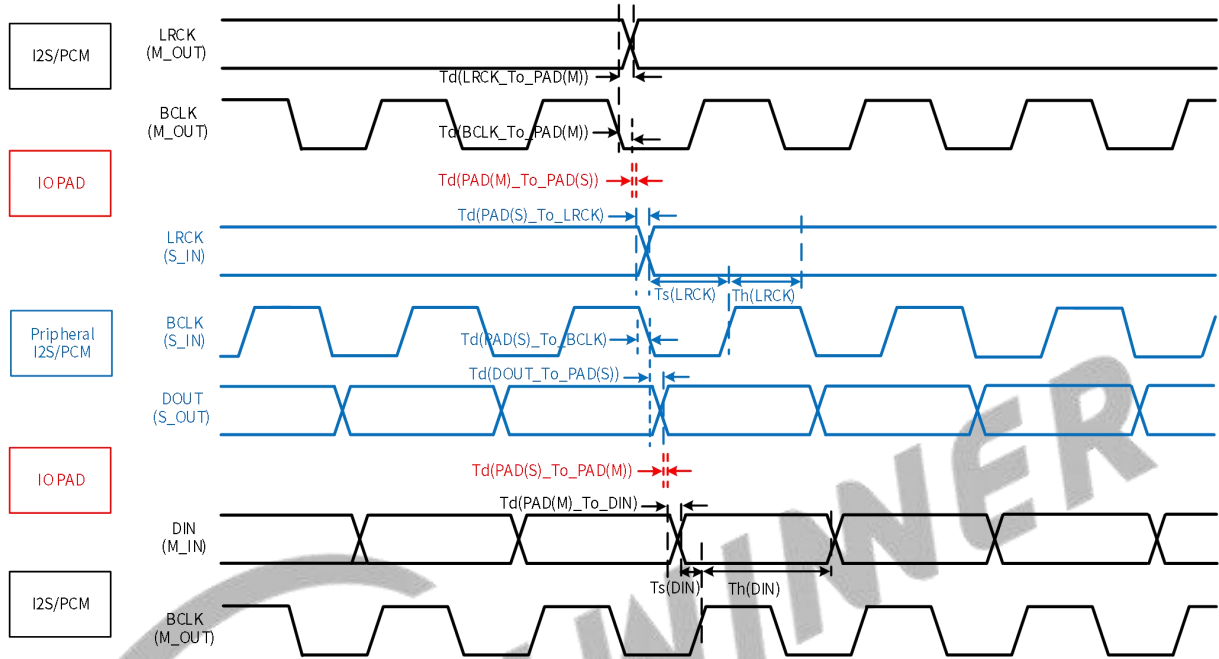

The Data Input timing parameters of I2S/PCM in Master mode and The Data Output timing parameters of Peripheral I2S/PCM in Slave mode are shown in Table 6-38.

Table 6-38 Data Input Timing Parameters of I2S/PCM in Master Mode

Parameter		Min	Max	Skew	Units
Sequence requirement of internal signal of I2S/PCM in Master mode					
Td(LRCK_To_PAD(M))	LRCK to PAD(M) Delay	/	T1<6.5(requirement)	Tw1<2.5 (estimation)	ns
Td(BCLK_To_PAD(M))	BCLK to PAD(M) Delay	/	T2<6.5(requirement)		ns
Sequence requirement of the IO pad of I2S/PCM in Master mode connecting to the external IO pad of Peripheral I2S/PCM in Slave mode					
Td(PAD(M)_To_PAD(S))	LRCK PAD(M) to LRCK PAD(S) Delay	/	T3*<7.0(requirement)	Tw2*<1.0 (estimation)	ns
	BCLK PAD(M) to BCLK PAD(S) Delay		T4*<7.0(requirement)		

Parameter		Min	Max	Skew	Units
Sequence requirement of internal signal of Peripheral I2S/PCM in Slave mode					
Td(PAD(S)_To_LRCK)	PAD(S) to LRCK Delay	/	T5*<6.5(requirement)	Tw3*<2.5 (estimation)	ns
Td(PAD(S)_To_BCLK)	PAD(S) to BCLK Delay	/	T6*<6.5(requirement)		ns
Td(DOUT_To_PAD(S))	DOUT to PAD(S) Delay	/	T7*<6.5(requirement)	/	ns
Ts(LRCK)	LRCK Setup Slack	T8*(analysis)	/	/	ns
Th(LRCK)	LRCK Hold Slack	T9*(analysis)	/	/	ns
Sequence requirement of the IO pad of I2S/PCM in Master mode connecting to the external IO pad of Peripheral I2S/PCM in Slave mode					
Td(PAD(S)_To_PAD(M))	DOUT PAD(S) to DIN PAD(M) Delay	/	T10*<7.0(requirement)	/	ns
Sequence requirement of internal signal of I2S/PCM in Master mode					
Td(PAD(M)_To_DIN)	PAD(M) to DIN Delay	/	T11<6.5(requirement)	/	ns
Ts(DIN)	DIN Setup Slack	T12*(analysis)	/	/	ns
Th(DIN)	DIN Hold Slack	T13*(analysis)	/	/	ns

6.11.11 OWA Interface Timing

Figure 6-38 OWA Timing

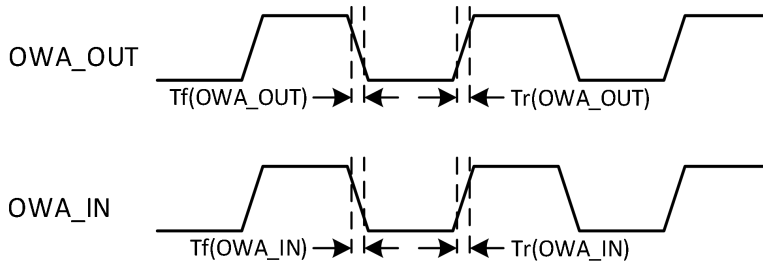

Table 6-39 OWA Timing Constants

Parameter	Symbol	Min	Typ	Max	Unit
OWA_OUT Rise Time	Tr(OWA_OUT)	-	-	8	ns
OWA_OUT Fall Time	Tf(OWA_OUT)	-	-	8	ns
OWA_IN Rise Time	Tr(OWA_IN)	-	-	4	ns
OWA_IN Fall Time	Tf(OWA_IN)	-	-	4	ns

6.12 Power-On and Power-Off Sequence

6.12.1 Power-On Sequence

The following figure shows an example of the power-on sequence for the A523 device. The description of the power-on sequence is as follows:

- VCC-LVDS0 must be ramped before VCC-PD.
- VCC-MCSI must be ramped before VCC-PK.
- VCC-EFUSE must be ramped after VDD-SYS.

Figure 6-39 Power-on Timing

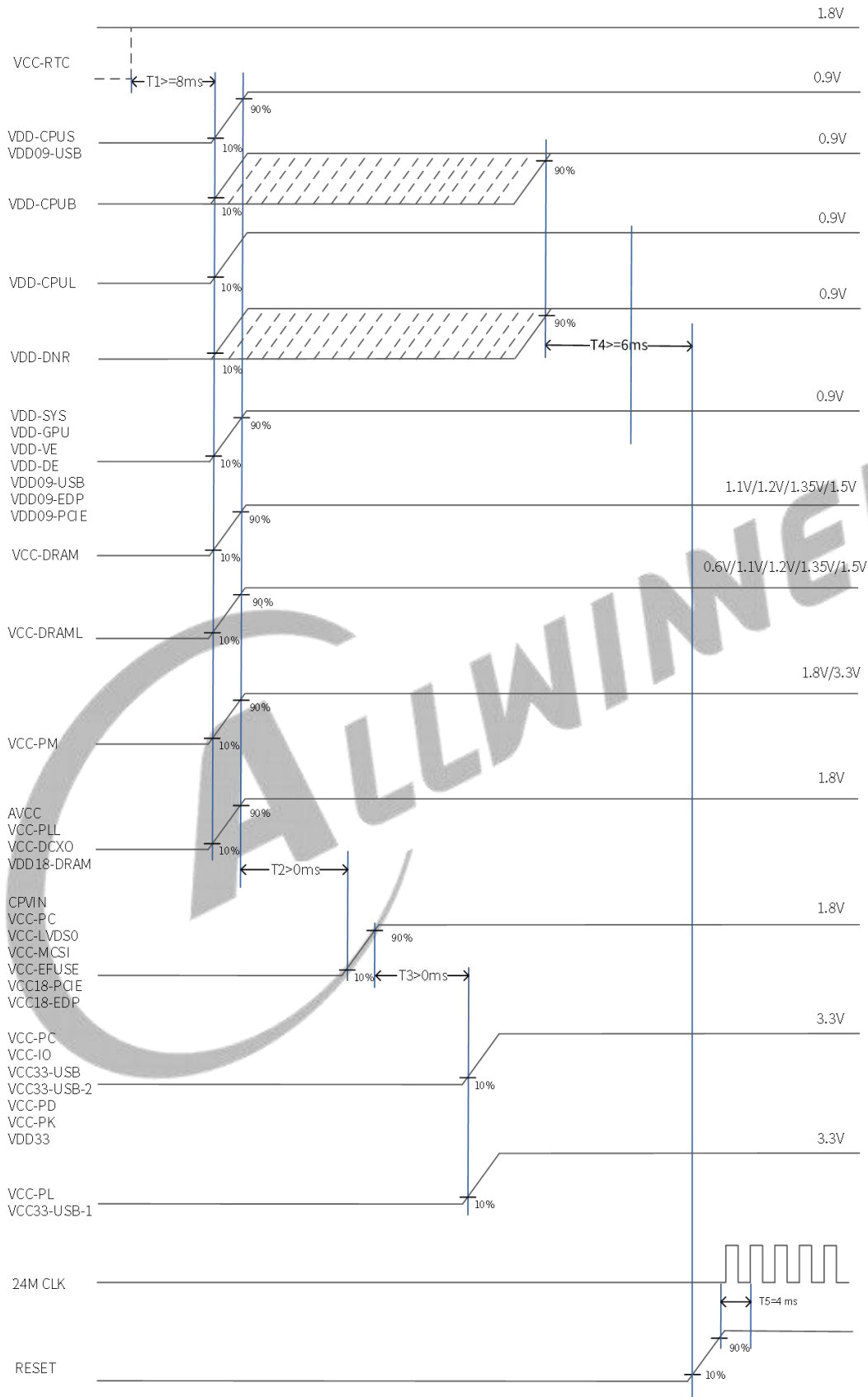

6.12.2 Power-Off Sequence

Figure 6-40 Power-off Timing

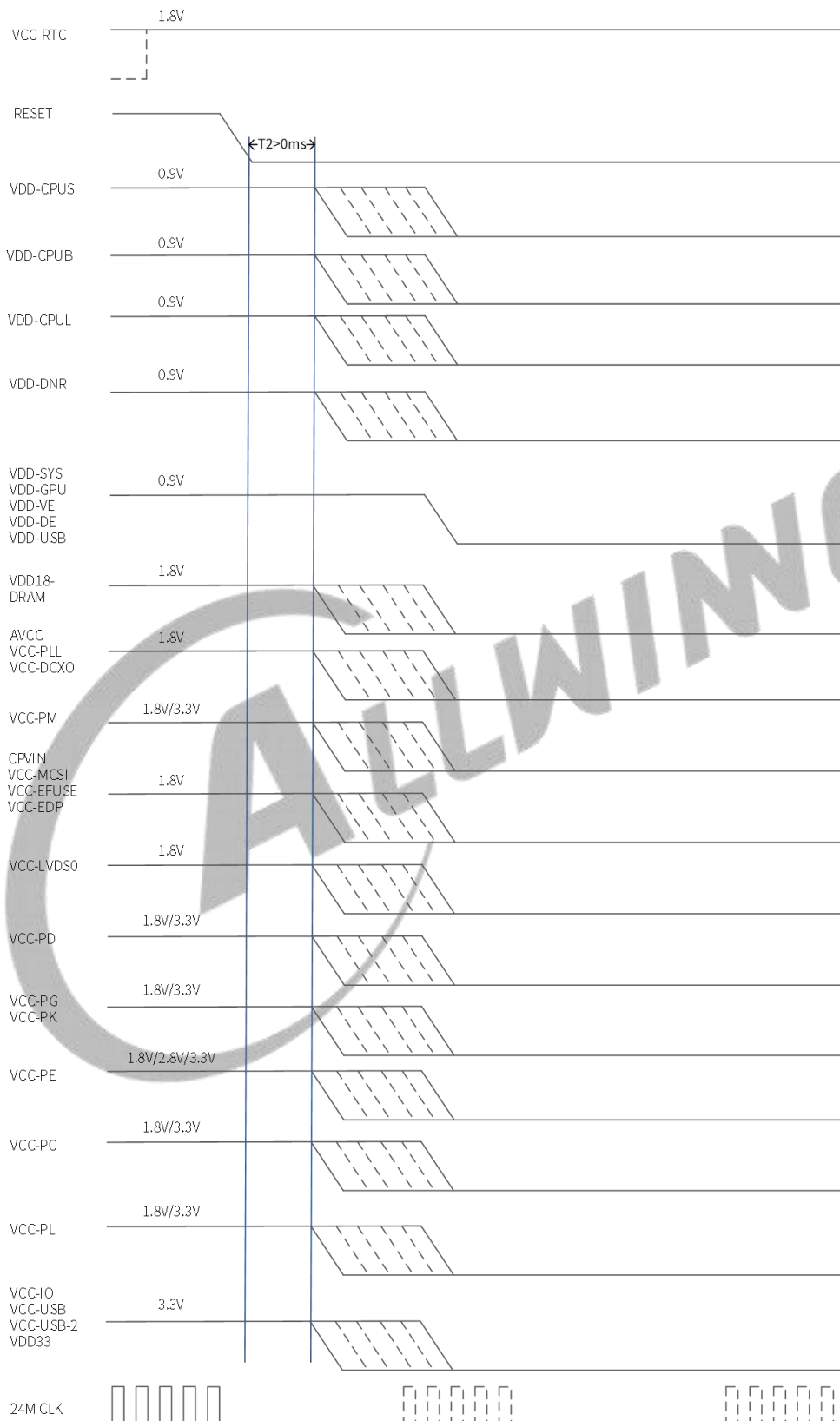

7 Temperature and Thermal Characteristics

7.1 Temperature

The following tables describe the temperature of A523.

Table 7-1 Operating and Storage Temperature

Symbol	Parameter	Min	Max	Unit
T _a	Ambient Operating Temperature	-25	75	°C
T _{STG}	Storage Temperature	-40	150	°C

Table 7-2 Junction Temperature

Chip	Working junction temperature (T _j)		Destructive Junction Temperature ⁽²⁾	Unit
	Min	Max ⁽¹⁾		
A523 Series	-25	115	125	°C

- (1) The junction temperature of the chip should be less than or equal to this value under normal operating conditions.
- (2) The junction temperature of chip should not be more than this value under any conditions.

7.2 Package Thermal Characteristics

The maximum chip junction temperature (T_j max) must never exceed the values given in Table 7-2 Junction Temperature.

Failure to maintain a junction temperature within the range specified reduces operating lifetime, reliability, and performance, and may cause irreversible damage to the system. It is useful to calculate the exact power consumption and junction temperature to determine which the temperature will be best suited to the application. Therefore, the product should include thermal analysis and thermal design to ensure the operating junction temperature of the device is within functional limits.

The following tables show the thermal resistance characteristics of the A523. These data are based on JEDEC JESD51 standard, because the actual system design and temperature could be different from JEDEC JESD51, these simulating data are a reference only and may not represent actual use-case values, please prevail in the actual application condition test.

Table 7-3 A523 Package Thermal Characteristics

Symbol	Parameter	Min	Typ ⁽¹⁾⁽²⁾	Max	Unit
--------	-----------	-----	-----------------------	-----	------

Symbol	Parameter	Min	Typ ⁽¹⁾⁽²⁾	Max	Unit
θ_{JA}	Junction-to-Ambient Thermal Resistance	-	30.09	-	°C/W
θ_{JB}	Junction-to-Board Thermal Resistance	-	10.47	-	°C/W
θ_{JC}	Junction-to-Case Thermal Resistance	-	1.6	-	°C/W

- (1) Reference document: JESD51-2 Integrated Circuits Thermal Test Method Environment Conditions—Natural Convection (Still Air). Available from www.jedec.org.
- (2) The testing PCB is 4 layers, 114.3 mm x 76.2 mm body, and 1.6mm thickness. Ambient temperature is 25 °C.



8 Pin Assignment

8.1 Pin Map

For A523, FCCSP 522balls balls, 15 mm x 15 mm, 0.5 mm ball pitch, 0.3 mm ball size package is offered. The following figure shows the pin map of the A523.

Figure 8-1 A523 Pin Map

	1	2	3	4	5	6	7	8	9	10	11	12	13	14	15	16	17	18	19	20	21	22	23	24	25	26	27	28	29
A	GND	GND	PK2	PK0	PH16	PH14		PH11		PH4		PF3		AVSS		PCIE-RX0-DP/USB3-RXP		USB0-DP		EDP-TX1P		EDP-TX3P		PD0	PD2	PD4	PD6	PD8	GND
B	PK5	PK4	PK3	PK1	PH17	PH15	PH13	PH10	PH5	PH3	PF5	PF2	PF1	PCIE-REF-CLKP	PCIE-TX0-DP/USB3-TXP	PCIE-RX0-DN/USB3-RXN	USB2-DP	USB0-DM	EDP-TX0P	EDP-TX1N	EDP-TX2P	EDP-TX3N	EDP-AUXP	PD1	PD3	PD5	PD7	PD9	GND
C	PK13	PK12	GND	PK7	PK6	GND	PH12	GND	PH6	GND	PF4	PF6	PF0	PCIE-REF-CLKN	PCIE-TX0-DN/USB3-TXN	AVSS	USB2-DM	AVSS	EDP-TX0N	AVSS	EDP-TX2N	AVSS	EDP-AUXN	GND	GND	GND	GND	PD10	PD11
D	PK15	PK14				PH18	PH9	PH2				GND		AVSS		USB2-REXT		USB1-REXT		USB1-DP		EDP-REXT						PD12	PD13
E	PK17	PK16	GND	PK9	PK8	PH19		PH8		PH1		FEL		PCIE-REXT		VCC33-18-USB-2		USB0-REXT		USB1-DM		EDP-HPD		GND	PD17	PD16	GND	PD14	PD15
F	PK18	PK19					PH7		PH0		JTAG-SEL			NC		AVSS		AVSS		AVSS		AVSS						PD19	PD18
G	PK21	PK20	GND	PK11	PK10	GND	GND																GND	GND	PD22	PD23	GND	PD20	PD21
H	PK23	PK22						GND	VCC-MCSI	GND	VCC18-PCIE	AVSS	VDD09-PCIE	VDD09-USB	AVSS	VCC33-USB	VCC33-18-USB	AVSS	VCC18-EDP	VDD09-EDP							PB2	PB3	
J	PE0	PE1	GND	PE8	PE9	VCC-PE	VCC-PK			GND		VCC-IO	AVSS		VCC33-USB-2	AVSS		AVSS	AVSS			GND	VCC-PD	PB0	PB1	GND	PB4	PB5	PB6
K	PE3	PE2						GND	VDD-VE		GND			GND	GND		GND	VDD-DE		VCC-LVDS0							PB7	PB8	
L	PE4	PE5	GND	PE12	PE13	GND	GND		GND	VDD-VE		GND		VDD-SYSFB	GND		VDD-DE	VDD-DE		GND		GND		PB9	PB10	PB11	PB12	PB13	PB14
M	PE6	PE7						GND	GND		VDD-SYS		VDD-SYS	VDD-SYS	GND			VDD-CPUBFB		GND							PC16	PC15	
N	PE10	PE11	GND	PE14	PE15	VCC-PG	GND	VDD-GPU	VDD-GPU		GND	GND		GND	VDD-CPUB	VDD-CPUB	VDD-CPUB	VDD-CPUB	GND	VCC-PC	VCC-EFUSE	PC4	PC3	PC2	PC14	PC13	PC12		
P		PG3	PG2					VDD-GPU	VDD-GPU	GND		GND		VDD-CPUB	VDD-CPUB	VDD-CPUB	VDD-CPUB										PC11	PC10	
R	PG0	PG1	GND	PG8	PG6	GND	GND							GND	GND								GND	PC0	PC7	GND	PC9	PC8	PC6
T		PG5	PG4					GND	GND		GND	GND			VDD-CPUL	VDD-CPUL	GND	VCC-DRAM	VCC-DRAM	VCC-DRAM							PC1	PC5	
U	PG10	PG11	PG7	PG9	PG14	VCM-ADC	VREFN-ADC		VDD-DNR	VDD-DNR		GND		GND	VDD-CPUL	VDD-CPUL	GND	GND	VCC-DRAM				SDQ15	SDQ14	SZQ	GND	SDQ13	GND	SDQ12
V		PG12	PG13					VDD-DNR	VDD-DNR		GND	GND		GND	VDD-CPULFB		GND	GND		VCC-DRAM							SDQS1P	SDQSIN	
W	GND	GPADC0	GPADC1	GPADC2	GPADC3	VREFP-ADC	AVCC	GND	GND	VDD-DNRFB		GND		GND							VCC-DRAM		SDQ8	SDQ9	GND	SDQ10	SDQ11	SDQM1	GND
Y	LRADC0	LRADC1									VDD-CPUS		VCC-DRAML	VCC-DRAML	VCC-DRAML	VCC-DRAML		VCC-DRAML		VCC-DRAM							SDQ5	SDQ7	
AA	MICIN1N	MICIN1P	AGND	VRP	VDD33	GND	GND		VCC-PL	VCC-RTC	GND	VCC-DCX0				GND	GND	GND	GND	VDD18-DRAM		SDQ1	SDQ0	GND	SDQ4	SDQ6	GND	SDQM0	
AB	MICIN2N	MICIN2P										VCC-PLL															SDQS0P	SDQS0N	
AC	MICIN3N	MICIN3P	VRA2	VRA1	CPVEE		VCC-PM		PL10		RESET		GND		SDQ24		SDQ23		SRST		GND		GND	SA10	SA1	GND	SDQ2	GND	
AD	LINEOUTLN	LINEOUTLP					GND		PL11		HMI		PLLTEST		SDQ25		SDQ31		SDQ18		SA4		GND			GND	SDQ3		
AE	LINEOUTRN	LINEOUTRP	ALDO-OUT	VEE	CPVDD		PL13		PL6		TEST		WREQIN		GND		GND		GND		SBA1		SA16		SA17	SA9	SA11	SA2	
AF	MIC-DET	HP-DET					PL12		PL7		GND		GND		SDQ26		SDQ30		SDQ19		SBA0		SA5		SA13		GND	SA0	
AG	MBIAS	HBIAS	CPVIN		GND		GND		PL9	PL8	X32KOUT	GND	GND	GND	SDQ27		SDQ29		SDQ20		SA8		SA3		SACT		SA12	SODT0	SODT1
AH	HPOUTL	HPOUTFB	GND	PM3	PM2	PM5	PL1	PL3	PL4	GND	X32KOUT	X32KIN	DXIN	REFCLK-OUT	SDQS3P	GND	SDQ28	SDQ21	SDQS2P	SDQM2	SDQ16	GND	SBG1	SA14	GND	SCKP	SCKE0	SCS1	SA7
AJ	GND	HPOUTR	PM1	PM0	PM4	GND	PL0	PL2	PL5		GND		DXOUT		SDQS3N	SDQM3	SDQ22	GND	SDQS2N	GND	SDQ17	SBG0	SA6	GND	SA15	SCKN	GND	SCS0	GND

8.2 Package Dimension

The following figure shows the top, bottom, and side views of A523 package dimension.

Figure 8-2 A523 Package Dimension

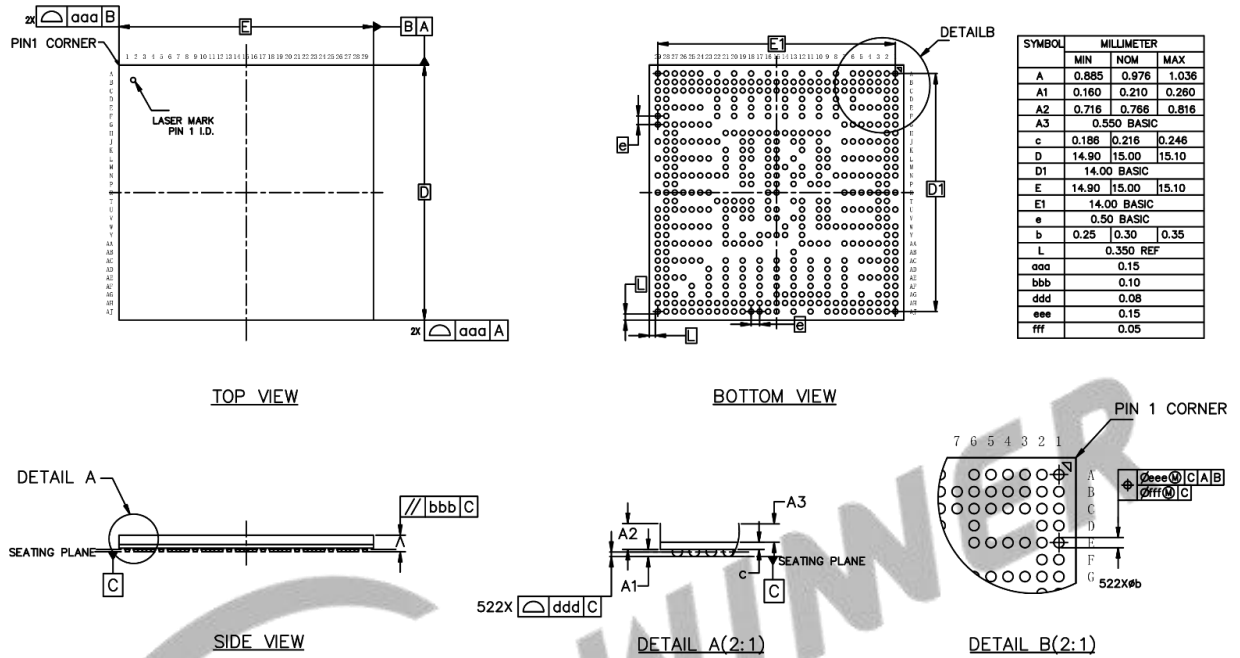

9 Carrier, Storage and Backing Information

9.1 Carrier

The following table shows the A523 matrix tray carrier information.

Table 9-1 Matrix Tray Carrier Information

Item	Color	Size	Note
Tray	Black	322.6 mm x 135.9 mm x 7.62 mm	126 Qty/Tray
Aluminum foil bags	Silvery white	540 mm x 300 mm x 0.14 mm	Vacuum packing Including HIC and desiccant Printing: RoHS symbol
Pearl cotton cushion (Vacuum bag)	White	12 mm x 680 mm x 185 mm	
Pearl cotton cushion (The Gap between vacuum bag and inner box)	White	Left-Right: 12 mm x 180 mm x 85 mm Front-Back: 12 mm x 350 mm x 70 mm	
Inner Box	White	396 mm x 196 mm x 96 mm	Printing: RoHS symbol 10 Tray/Inner box
Carton	White	420 mm x 410 mm x 320 mm	6 Inner box/Carton

The following table shows the A523 packing quantity.

Table 9-2 A523 Packing Quantity Information

Sample	Size (mm)	Qty/Tray	Tray/Inner Box	Full Inner Box Qty	Inner Box/Carton	Full Carton Qty
A523 Series	15 x 15	126	10	1260	6	7560

The following figure shows tray dimension drawing of the A523.

Figure 9-1 A523 Tray Dimension Drawing

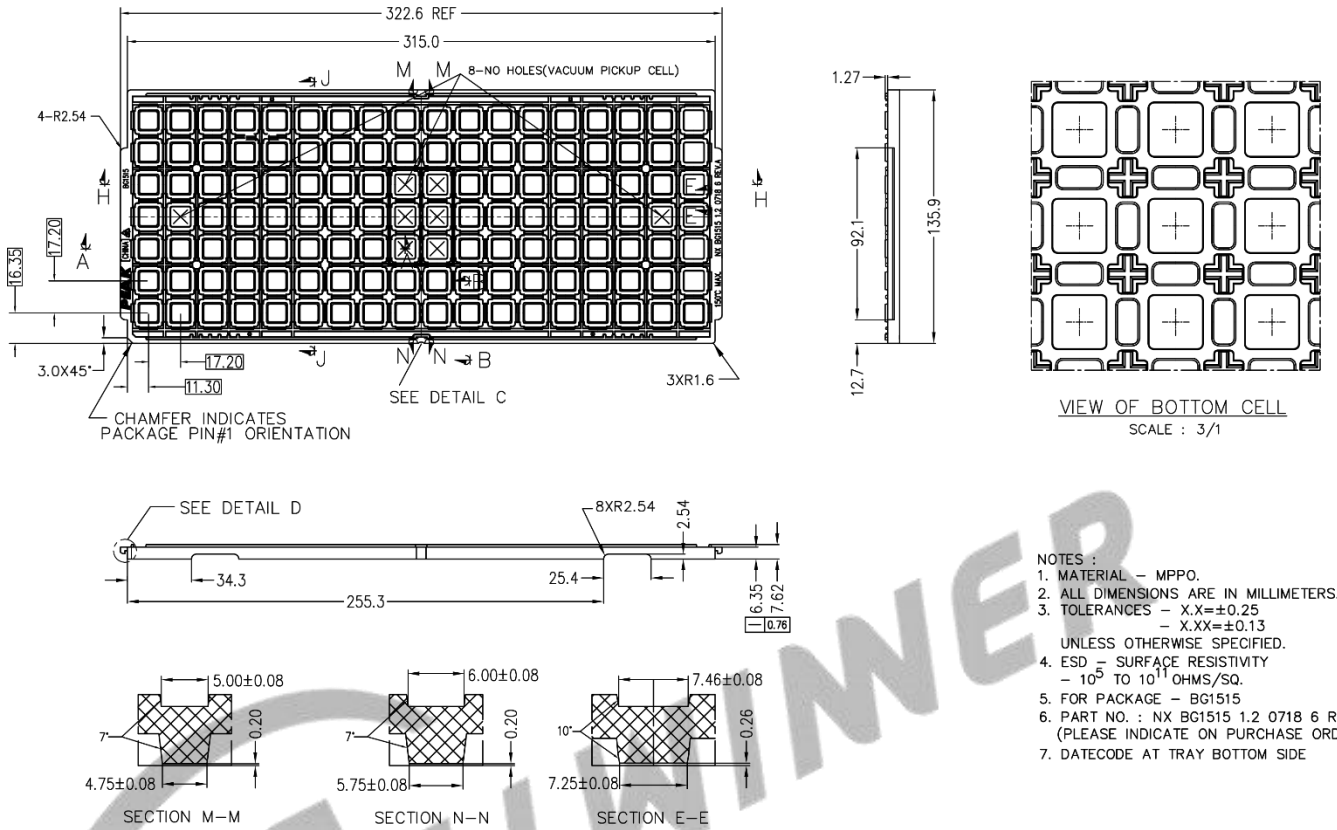

9.2 Storage

Reliability is affected if any condition specified in Section 8.2.2 and Section 8.2.3 has been exceeded.

9.2.1 Moisture Sensitivity Level (MSL)

A package' s MSL indicates its ability to withstand exposure after it is removed from its shipment bag, a low MSL device sample can be exposed on the factory floor longer than a high MSL device sample. Table 9-3 defines all MSL.

Table 9-3 MSL Summary

MSL	Out-of-bag floor life	Comments
1	Unlimited	≤ 30°C / 85%RH
2	1 year	≤ 30°C / 60%RH
2a	4 weeks	≤ 30°C / 60%RH
3	168 hours	≤ 30°C / 60%RH
4	72 hours	≤ 30°C / 60%RH

MSL	Out-of-bag floor life	Comments
5	48 hours	≤30°C / 60%RH
5a	24 hours	≤30°C / 60%RH
6	Time on Label (TOL)	≤30°C / 60%RH

 NOTE

The A523 device samples are classified as MSL3.

9.2.2 Bagged Storage Conditions

The following table defines the shelf life of the A523 device samples.

Table 9-4 Bagged Storage Conditions

Packing mode	Vacuum packing
Storage temperature	20-26°C
Storage humidity	40%-60%RH
Shelf life	12 months

9.2.3 Out-of-bag Duration

It is defined by the device MSL rating. The out-of-bag duration of the A523 is as follows.

Table 9-5 Out-of-bag Duration

Storage temperature	20-26°C
Storage humidity	40%-60%RH
Moisture sensitive level (MSL)	3
Floor life	168 hours

For no mention of storage rules in this document, refer to the latest *IPC/JEDEC J-STD-020C*.

9.3 Baking

It is not necessary to bake the A523 if the conditions specified in Section 8.2.2 and Section 8.2.3 have not been exceeded. It is necessary to bake the A523 if any condition specified in Section 8.2.2 and Section 8.2.3 has been exceeded.

It is necessary to bake the A523 if the storage humidity condition has been exceeded, we recommend that the device sample removed from its shipment bag for more than 2 days shall be baked to guarantee production.

Baking conditions: 125°C, 8 hours, nitrogen protection. Note that the baking should not exceed 1 times due to a risk of deformation.



10 Reflow Profile

All Allwinner chips provided for clients are lead-free RoHS-compliant products.

The reflow profile recommended in this document is a lead-free reflow profile that is suitable for pure lead-free technology of lead-free solder paste. If customers need to use lead solder paste, contact Allwinner FAE.

The following figure shows the appropriate reflow profile.

Figure 10-1 Lead-free Reflow Profile

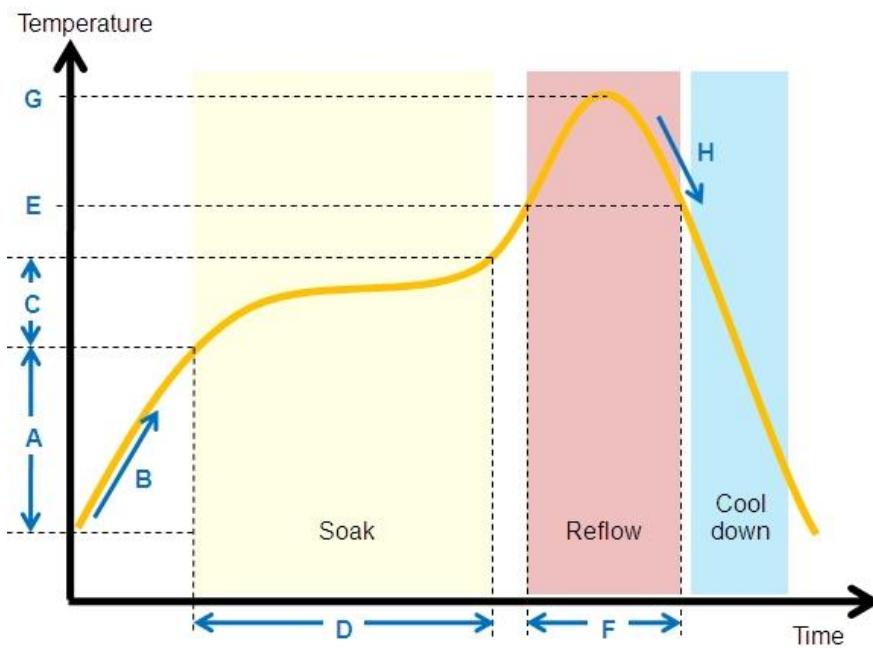

Table 10-1 Lead-free Reflow Profile Conditions

	QTI typical SMT reflow profile conditions (for reference only)	
	Step	Reflow condition
Environment	N2 purge reflow usage (yes/no)	Yes, N2 purge used
	If yes, O2 ppm level	O2 < 1500 ppm
A	Preheat ramp up temperature range	25 °C -> 150 °C
B	Preheat ramp up rate	1.5-2.5 °C/s
C	Soak temperature range	150 °C -> 190 °C
D	Soak time	80-110 s
E	Liquidus temperature	217°C
F	Time above liquidus	60-90 s
G	Peak temperature	240-250 °C
H	Cool down temperature rate	≤4°C/s

The method of measuring the reflow soldering process is as follows.

Fix the thermocouple probe of the temperature measuring line at the connection point between the pin (solderable end) of the packaged device and the pad by using high-temperature solder wire or high-temperature tape, fix the packaged device at the pad by using high-temperature tape or other methods, and cover over the thermocouple probe. See Figure 10-2.

Figure 10-2 Measuring the Reflow Soldering Process

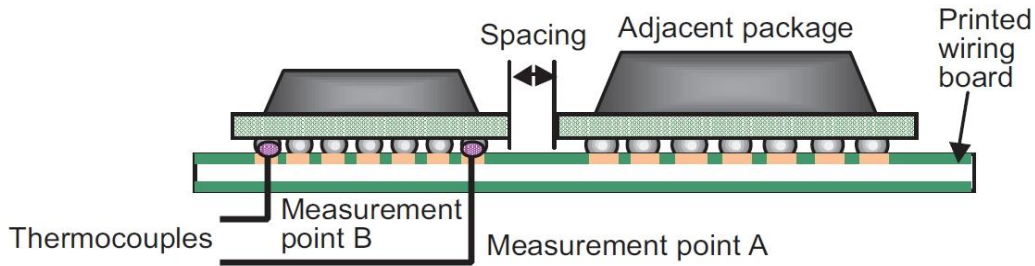

 **NOTE**

To measure the temperature of the QFP-packaged chip, place the temperature probe directly at the pin.

If possible, the more accurate measuring way is to drill the packaged device, or drill the PCB, and fix the thermocouple probe through the drilled hole at the pad.

11 FT/QA/QC Test

11.1 FT Test

FT test is the finished product testing after the chip is packaged, and it is a functional test of all modules for each produced chip.

11.2 QA Test

QA test is a system-level sampling test for good-quality chips. According to the application level of the chip, a certain percentage of good-quality chips are selected for system-level testing to make the chip work in a typical application scenario, and judge whether the chip works normally in this scenario.

11.3 QC Test

QC test is a module-level sampling test for good-quality chips. According to the chip application level, a certain percentage of good-quality chips are selected for module-level functional testing to monitor whether the chip production process is normal.

12 Part Marking

12.1 A523H00X0000

The following figure shows the A523H00X0000 marking.

Figure 12-1A523H00X0000 Marking



The following table describes the A523H00X0000 marking definitions.

Table 12-1 A523H00X0000 Marking Definitions

No.	Marking	Description	Fixed/Dynamic
1	ALLWINNER	Allwinner logo or name	Fixed
2	A523H00X0000	Product name	Fixed
3	LLLLLBA	Lot number	Dynamic
4	XXXF	Date code	Dynamic

12.2 A523M00X0000

The following figure shows the A523M00X0000 marking.

Figure 12-2 A523M00X0000 Marking

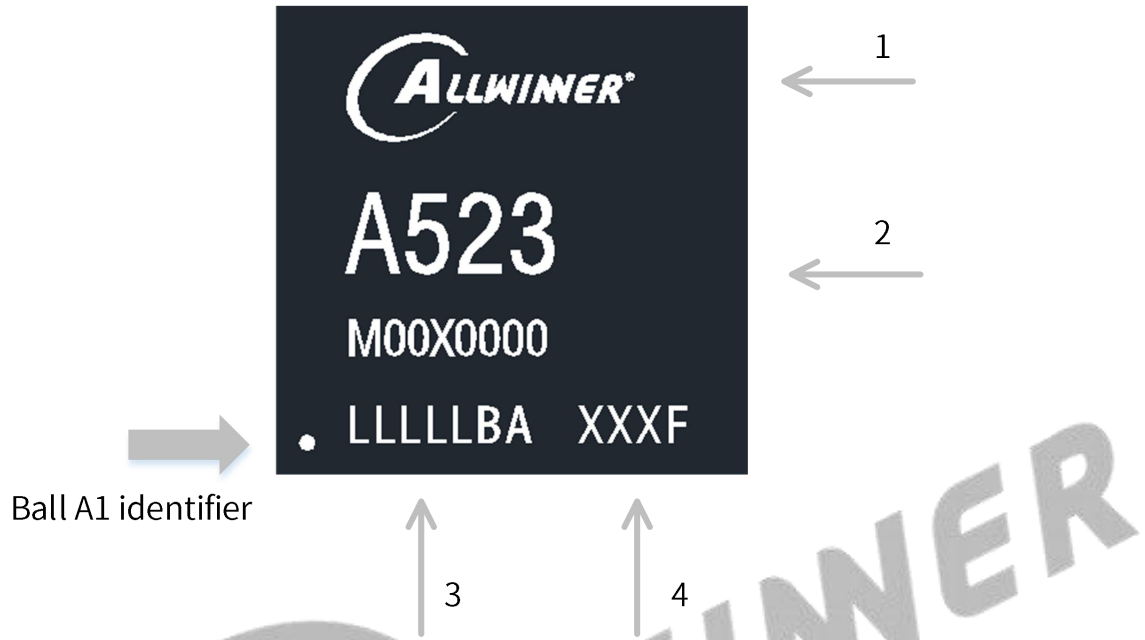

The following table describes the A523M00X0000 marking definitions.

Table 12-2 A523M00X0000 Marking Definitions

No.	Marking	Description	Fixed/Dynamic
1	ALLWINNER	Allwinner logo or name	Fixed
2	A523M00X0000	Product name	Fixed
3	LLLLLBA	Lot number	Dynamic
4	XXXF	Date code	Dynamic

Copyright©2023 Allwinner Technology Co., Ltd. All Rights Reserved.

This documentation is the original work and copyrighted property of Allwinner Technology Co., Ltd (“Allwinner”). No part of this document may be reproduced, modify, publish or transmitted in any form or by any means without prior written consent of Allwinner.

Trademarks and Permissions

Allwinner and the Allwinner logo (incomplete enumeration) are trademarks of Allwinner Technology Co., Ltd. All other trademarks, trade names, product or service names mentioned in this document are the property of their respective owners.

Important Notice and Disclaimer

The purchased products, services and features are stipulated by the contract made between Allwinner Technology Co., Ltd (“Allwinner”) and the customer. All or part of the products, services and features described in this document may not be within the purchase scope or the usage scope. Please read the terms and conditions of the contract and relevant instructions carefully before using, and follow the instructions in this documentation strictly. Allwinner assumes no responsibility for the consequences of improper use (including but not limited to overvoltage, overclock, or excessive temperature).

The information in this document is provided just as a reference or typical applications, and is subject to change without notice. Every effort has been made in the preparation of this document to ensure accuracy of the contents. Allwinner is not responsible for any damage (including but not limited to indirect, incidental or special loss) or any infringement of third party rights arising from the use of this document. All statements, information, and recommendations in this document do not constitute a warranty or commitment of any kind, express or implied.

No license is granted by Allwinner herein express or implied or otherwise to any patent or intellectual property of Allwinner. Third party licences may be required to implement the solution/product. Customers shall be solely responsible to obtain all appropriately required third party licences. Allwinner shall not be liable for any licence fee or royalty due in respect of any required third party licence. Allwinner shall have no warranty, indemnity or other obligations with respect to third party licences.



Copyright © 2023 Allwinner Technology Co., Ltd. All Rights Reserved.

Allwinner Technology Co., Ltd.

No.9 Technology Road 2, High-Tech Zone,
Zhuhai, Guangdong Province, China

Contact US:

Service@allwinnertech.com

www.allwinnertech.com