







Dual-Core Intelligent Voice Interaction Chip

The Most Performance Speaker Solution

Overview

With the cost-effective dual-core Cortex™-A53 CPU, dual-core HiFi4, and 0.25T NPU accelerator, the R329 provides powerful, energy-efficient computing power for audio applications, supporting mainstream voice pick and play solutions. Integrated 5 differential ADC channels and 2 differential DAC channels for direct use in a four-microphone mono or triple-microphone stereo speaker solution; 8 PDM channels and 16 I2S channels for richer microphone arrays and speaker output solutions. The outstanding audio engine supports all major high-resolution audio formats and works seamlessly with the CPU to accelerate multimedia algorithms and improve the user experience. The R329 is the ideal SoC for the smart speaker and smart home market.

Highlights

-  **High Integration**
R329 integrates powerful processor, 256 MB or 128 MB DDR3, and high performance 5 ADC, 2 DAC, 3 I2S, 8 DMIC, 2 LDOs, which provides the perfect voice interaction solution.
-  **High Performance**
Dual-core Cortex™-A53 CPU up to 1512 MHz, Dual-core HiFi4 DSP up to 400MHz, ARM Zhoyi Z1 AIPU 0.25T providing powerful computing power. Audio DACs which performance 100dB SNR@A-weight and -85dB THD+N, make the best sound quality in the industry.
-  **Low Power Design**
Advanced 28 nm process design with lower voltage and lower leakage, power optimization design for typical scenes, enhanced heat dissipation package, improved the heating experience of the product. NR, AEC and keyword recognition can be run in HiFi4 DSP, which achieve wake-up standby power consumption of less than 50 mW.
-  **High Quality Assurance**
Industrial level working temperature, 10-years chip life.

Features

CPU	<ul style="list-style-type: none">• Dual-core ARM Cortex™-A53@1512 MHz• 32 KB L1 I-cache + 32 KB L1 D-cache per core• 256 KB L2 cache
DSP	<ul style="list-style-type: none">• Dual-core HiFi4@400MHz• 32 KB L1 I-cache + 32 KB L1 D-cache per core• 2 MB SRAM
AIPU	<ul style="list-style-type: none">• Arm China Zhouyi Z1 AIPU, 1TEC+128mac FF (Only for R329-N3 and R329-N4)• 0.25TOPS@600MHz
Memory	<ul style="list-style-type: none">• Embedded with 256 MB DDR3 (only for R329-N4)• Embedded with 128 MB DDR3 (only for R329-N3 and R329-S3)• Supports SPI Nand/Nor/eMMC
Audio	<ul style="list-style-type: none">• Supports 5 audio ADC and 2 audio DAC• Supports 5 analog audio inputs and 2 analog audio outputs• Up to 3 I2S/PCM controllers for Bluetooth and external audio codec• Integrated digital microphone, supports maximum 8 digital microphones
Security Engine	<ul style="list-style-type: none">• Supports Symmetrical algorithm: AES, DES, 3DES• Supports Hash algorithm: MD5, SHA, HMAC• Supports Pubic Key algorithm: RSA• Supports 160-bit hardware PRNG with 175-bit seed• Supports 256-bit hardware TRNG• Supports 1K-bit EFUSE for chip ID and security application
Connectivity	<ul style="list-style-type: none">• USB 2.0 OTG x 1, USB 1.1 HOST x 1• SDIO 3.0• LEDC, PWM x 15• IR TX, IR RX x2• TWI x 3, SPI x 2, UART x 5• LRADC , GPADC x 4• EMAC, SCR
WIFI&BT	XR829 or others
OS	Linux 4.9
Package	<ul style="list-style-type: none">• LFBGA231 balls, 0.65 mm ball pitch, 0.35 mm ball size, 12 mm x 12 mm body (only for R329-N3 and R329-S3)• LFBGA228 balls, 0.65 mm ball pitch, 0.35 mm ball size, 12 mm x 14.5 mm body (only for R329-N4)
Process	28 nm HPC+

Block Diagram

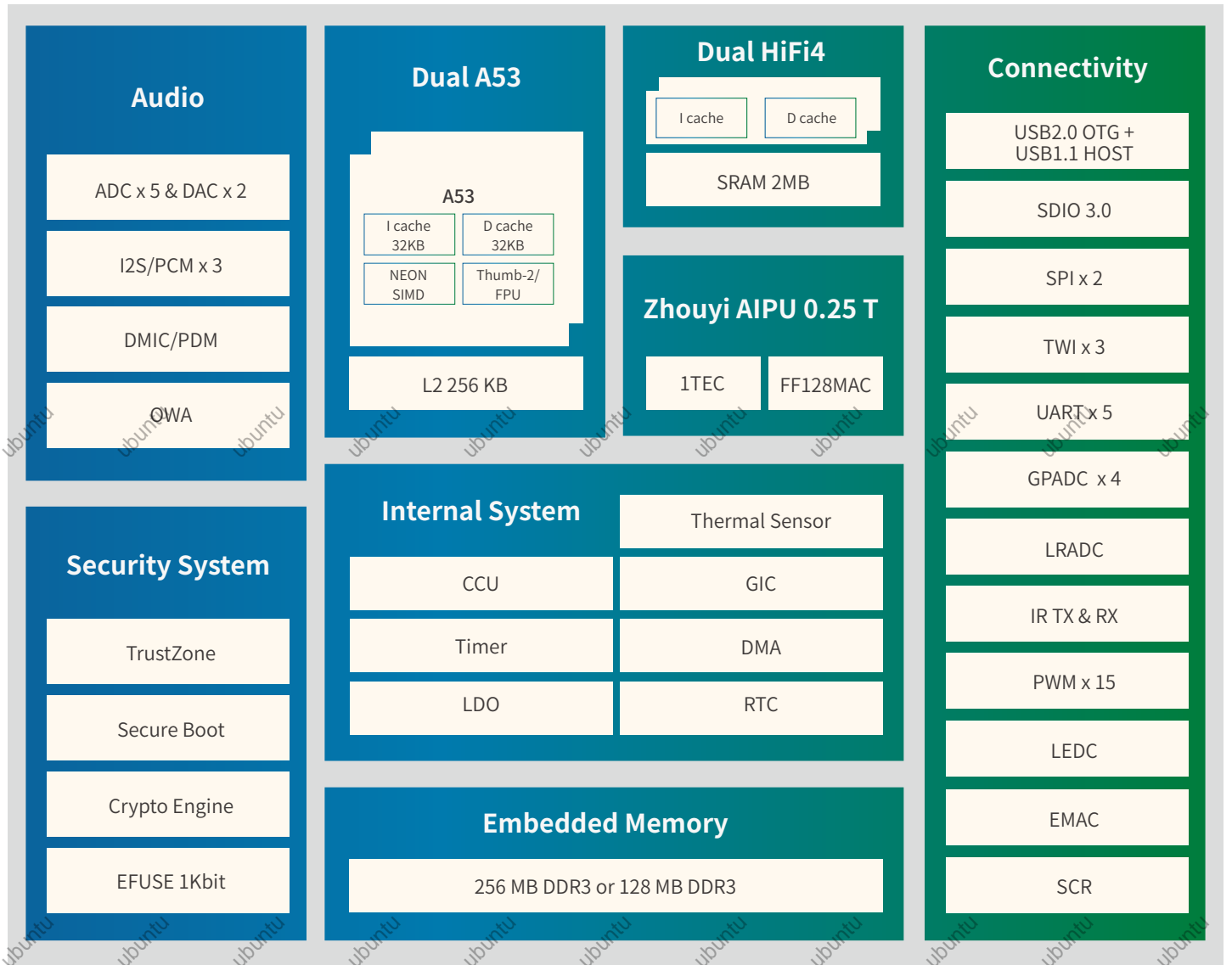

Note: R329-S3 does not support AIPU.

Application Diagram

Smart speaker solution

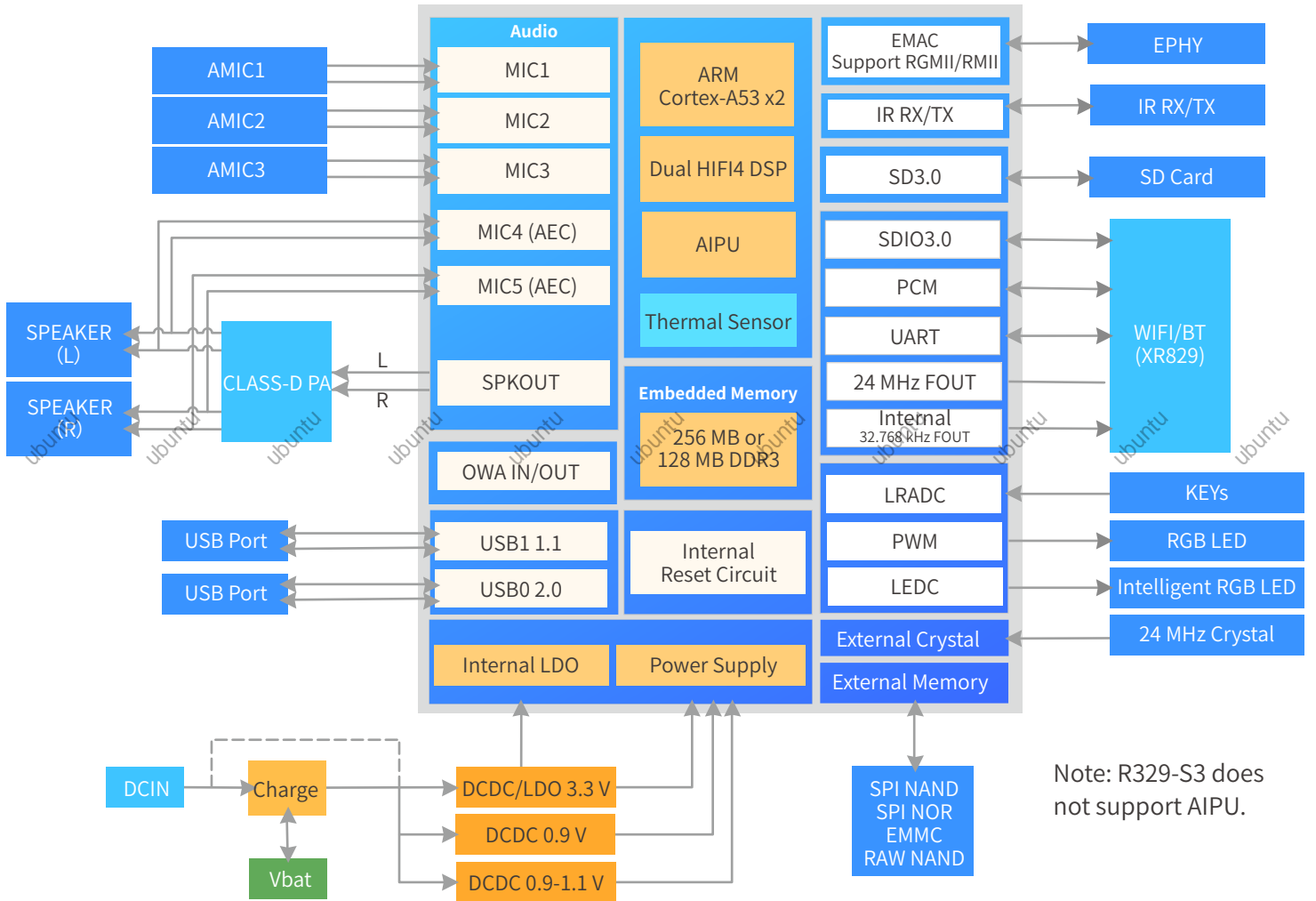

ABOUT ALLWINNER

Allwinner Technology is a leading fabless design company dedicated to smart application processor SoCs and smart analog ICs. Its product line includes multi-core application processors for smart devices and smart power management ICs used by brands worldwide.

With its focus on cutting edge UHD video processing, high performance multi-core CPU/GPU integration, and ultra-low power consumption, Allwinner Technology is a mainstream solution provider for the global tablet, internet TV, smart home device, automotive in-dash device, smart power management, and mobile connected device markets. Allwinner Technology is headquartered in Zhuhai, China.

CONTACT US

For more product info, please contact service@allwinnertech.com, or scan the QR code to follow us on Wechat.

This brief is for reference only and has no commitment. All content contained herein is subject to changes without notice.
©2020 Allwinner Technology Co., Ltd.

